

SECTION III
Rules for Construction of
Nuclear Facility Components

2021 ASME Boiler and
Pressure Vessel Code
An International Code

Division 1 — Subsection NE
Class MC Components

Markings such as “ASME,” “ASME Standard,” or any other marking including “ASME,” ASME logos, or the ASME Single Certification Mark shall not be used on any item that is not constructed in accordance with all of the applicable requirements of the Code or Standard. Use of the ASME Single Certification Mark requires formal ASME certification; if no certification program is available, such ASME markings may not be used. (For Certification and Accreditation Programs, see <https://www.asme.org/certification-accreditation>.)

Items produced by parties not formally possessing an ASME Certificate may not be described, either explicitly or implicitly, as ASME certified or approved in any code forms or other document.

AN INTERNATIONAL CODE

2021 ASME Boiler & Pressure Vessel Code

2021 Edition

July 1, 2021



RULES FOR CONSTRUCTION OF NUCLEAR FACILITY COMPONENTS

Division 1 - Subsection NE

Class MC Components

ASME Boiler and Pressure Vessel Committee
on Construction of Nuclear Facility Components



The American Society of
Mechanical Engineers

Two Park Avenue • New York, NY • 10016 USA

Date of Issuance: July 1, 2021

This international code or standard was developed under procedures accredited as meeting the criteria for American National Standards and it is an American National Standard. The Standards Committee that approved the code or standard was balanced to assure that individuals from competent and concerned interests have had an opportunity to participate. The proposed code or standard was made available for public review and comment that provides an opportunity for additional public input from industry, academia, regulatory agencies, and the public-at-large.

ASME does not “approve,” “certify,” “rate,” or “endorse” any item, construction, proprietary device, or activity.

ASME does not take any position with respect to the validity of any patent rights asserted in connection with any items mentioned in this document, and does not undertake to insure anyone utilizing a standard against liability for infringement of any applicable letters patent, nor assume any such liability. Users of a code or standard are expressly advised that determination of the validity of any such patent rights, and the risk of infringement of such rights, is entirely their own responsibility.

Participation by federal agency representative(s) or person(s) affiliated with industry is not to be interpreted as government or industry endorsement of this code or standard.

ASME accepts responsibility for only those interpretations of this document issued in accordance with the established ASME procedures and policies, which precludes the issuance of interpretations by individuals.

The endnotes and preamble in this document (if any) are part of this American National Standard.



ASME Collective Membership Mark



ASME Single Certification Mark

"ASME" and the above ASME symbols are registered trademarks of The American Society of Mechanical Engineers.

No part of this document may be reproduced in any form, in an electronic retrieval system or otherwise, without the prior written permission of the publisher.

Library of Congress Catalog Card Number: 56-3934
Printed in the United States of America

Adopted by the Council of The American Society of Mechanical Engineers, 1914; latest edition 2021.

The American Society of Mechanical Engineers
Two Park Avenue, New York, NY 10016-5990

Copyright © 2021 by
THE AMERICAN SOCIETY OF MECHANICAL ENGINEERS
All rights reserved

TABLE OF CONTENTS

List of Sections	vii
Foreword	ix
Statement of Policy on the Use of the ASME Single Certification Mark and Code Authorization in Advertising	xi
Statement of Policy on the Use of ASME Marking to Identify Manufactured Items	xi
Submittal of Technical Inquiries to the Boiler and Pressure Vessel Standards Committees	xii
Personnel	xv
Organization of Section III	xxxvi
Summary of Changes	xl
List of Changes in Record Number Order	xli
Cross-Referencing and Stylistic Changes in the Boiler and Pressure Vessel Code	xlii
Article NE-1000	
NE-1100	1
Article NE-2000	
NE-2100	1
NE-2200	8
NE-2300	8
NE-2400	12
NE-2500	15
NE-2600	19
NE-2700	23
Article NE-3000	
NE-3100	23
NE-3200	32
NE-3300	32
NE-3700	33
Article NE-4000	
NE-4100	33
NE-4200	39
NE-4300	59
NE-4400	87
NE-4600	88
NE-4700	88
NE-4800	89
Article NE-5000	
NE-5100	99
NE-5200	108
NE-5300	113

NE-5500	Qualifications and Certification of Nondestructive Examination Personnel	122
NE-5700	Examination Requirements for Expansion Joints	123
Article NE-6000	Testing	125
NE-6100	General Requirements	125
NE-6200	Hydrostatic Tests	126
NE-6300	Pneumatic Tests	126
NE-6400	Pressure Test Gages	127
NE-6700	Containment Penetration	127
Article NE-7000	Overpressure Protection	129
NE-7100	General Requirements	129
NE-7200	Overpressure Protection Report	130
NE-7300	Relieving Capacity Requirements	131
NE-7400	Set Pressures of Pressure Relief Devices	131
NE-7500	Operating Design Requirements for Pressure Relief Valves	131
NE-7700	Certification Requirements	132
NE-7800	Marking, Stamping With Certification Mark, and Data Reports	132
Article NE-8000	Nameplates, Stamping With Certification Mark, and Reports	133
NE-8100	Requirements	133
 Figures		
NE-1110-1	Typical Containment Penetrations	3
NE-1131-1	Some Typical Jurisdictional Boundaries for Welded Connections Class MC Containment Vessels	4
NE-1132.2-1	Attachments in the Containment Vessel Support Load Path That Do Not Perform a Pressure-Retaining Function	5
NE-1132.2-2	Attachments That Do Not Perform a Pressure-Retaining Function and Are Not in the Containment Vessel Support Load Path (Nonstructural Attachments)	6
NE-1132.2-3	Attachments That Perform a Pressure-Retaining Function	7
NE-2433.1-1	Weld Metal Delta Ferrite Content	23
NE-2575.2-1	Typical Pressure-Retaining Parts of Vessels	30
NE-3213.10-1	Example of Acceptable Local Primary Membrane Stress Due to Pressure Stress Categories and Limits of Stress Intensity for Design Conditions .	41
NE-3221-1	Stress Categories and Limits of Stress Intensity for Level A and B Service Limits; and for Level C Service Limits Where the Structure Is Not Integral and Continuous	49
NE-3221-2	Stress Categories and Limits of Stress Intensity for Level A and B Service Limits; and for Level C Service Limits Where the Structure Is Not Integral and Continuous	50
NE-3221-3	Stress Categories and Limits of Stress Intensity for Level C Service Limits Where the Structure Is Integral and Continuous; and for Level D Service Limits Where the Structure Is Not Integral and Continuous, and at Partial Penetration Welds	51
NE-3221-4	Stress Categories and Limits of Stress Intensity for Level D Service Limits Where the Structure Is Integral and Continuous	52
NE-3324.2-1	Principal Dimensions of Typical Heads	60
NE-3324.11(a)(6)-1	Large Head Openings: Reverse Curve and Conical Shell Reducer Sections	65
NE-3325-1	Some Acceptable Types of Unstayed Flat Heads and Covers	66
NE-3326.1-1	Spherically Dished Covers With Bolting Flanges	69
NE-3332.2-1	Chart for Determining Values of <i>F</i>	72

NE-3334.2-1	Nozzle Dimensions	74
NE-3335.1-1	Arrangement of Multiple Openings	75
NE-3338.2-1	Direction of Stress Components	77
NE-3351-1	Welded Joint Locations Typical of Categories A, B, C, and D	78
NE-3352-1	Typical Butt Joints	79
NE-3358.1(a)-1	Heads Attached to Shells	82
NE-3361-1	Category A and B Joints Between Sections of Unequal Thickness	84
NE-4221.1-1	Maximum Difference in Cross-Sectional Diameters	90
NE-4221.2-1	Maximum Permissible Deviation e From a True Circular Form	91
NE-4221.2-2	Maximum Arc Length for Determining Plus or Minus Deviation	92
NE-4243-1	Attachment of Pressure Parts to Plates to Form a Corner Joint	94
NE-4243-2	Acceptable Types of Full Penetration Weld Details for Category C Joints	95
NE-4243.1-1	Typical Flat Heads	96
NE-4244(a)-1	Nozzles Attached by Full Penetration Butt Welds	97
NE-4244(b)-1	Nozzles Attached by Full Penetration Corner Welds	98
NE-4244(c)-1	Deposited Weld Metal for Openings and Nozzles	100
NE-4244(d)-1	Acceptable Types of Welded Nozzles Using Partial Penetration Welds .	101
NE-4244(d)-2	Partial Penetration Weld Connections	102
NE-4244(d)-3	Partial Penetration Weld Connections for Coaxial Cylinders	103
NE-4244(e)-1	Acceptable Types of Fittings With Internal Threads	103
NE-4244(e)-2	Acceptable Types of Small Fittings	104
NE-4244(f)-1	Tube Connections	105
NE-4427-1	Fillet and Socket Weld Details and Dimensions	110
NE-4437(b)-1	Attachment of Stiffening Rings to Shell	112
NE-4730-1	Penetration Assembly	117
NE-4810(c)-1	Bellows Attachment Welds	118

Tables

NE-2121(a)-1	Material Specifications and Grades Permitted for Class MC Construction	9
NE-2121(a)-2	Permitted Bolting Material Specifications	10
NE-2311(a)-1	Exemptions From Impact Testing Under NE-2311(a)(8)	15
NE-2332.1-1	Required C_v Lateral Expansion Values for Pressure-Retaining Material Other Than Bolting	17
NE-2332.1-2	Required C_v Energy Values for Pressure-Retaining Material Other Than Bolting	18
NE-2332.3(a)-1	Required C_v Values for Bolting Material Tested in Accordance With NE-2332.3(a)	18
NE-2332.3(b)-1	Required C_v Values for Bolting Material Tested in Accordance With NE-2332.3(b) and NE-2333.2	18
NE-2333.1-1	Required C_v Energy Values for Pressure-Retaining Material Other Than Bolting for the Overpressure Test	18
NE-2432.1-1	Sampling of Welding Materials for Chemical Analysis	22
NE-2432.2-1	Welding Material Chemical Analysis	22
NE-2571-1	Required Examinations	28
NE-3217-1	Classification of Stress Intensity in Vessels for Some Typical Cases . . .	45
NE-3221-1	Summary of Stress Intensity Limits	48

NE-3228.3(b)-1	Values of m , n , and T_{\max} for Various Classes of Permitted Materials . . .	58
NE-3324.2-1	Values of Factor K	60
NE-3324.8(b)-1	Values of Factor M	63
NE-3324.11(b)(2)-1	Values of Δ for Junctions at the Large Cylinder for $\alpha \leq 30$ deg	64
NE-3324.11(b)(3)-1	Values of Δ for Junctions at the Small Cylinder for $\alpha \leq 30$ deg	64
NE-3332.2-1	Values of Spherical Radius Factor K_1	73
NE-3338.2(c)-1	Stress Indices for Nozzles	77
NE-4232-1	Maximum Allowable Offset in Final Welded Joints	93
NE-4622.1-1	Mandatory Requirements for Postweld Heat Treatment (PWHT) of Welds	114
NE-4622.4(c)-1	Alternative Holding Temperatures and Times	114
NE-4622.7(b)-1	Exemptions to Mandatory PWHT	115
Endnotes	134

LIST OF SECTIONS

(21)

SECTIONS

- I Rules for Construction of Power Boilers
- II Materials
 - Part A — Ferrous Material Specifications
 - Part B — Nonferrous Material Specifications
 - Part C — Specifications for Welding Rods, Electrodes, and Filler Metals
 - Part D — Properties (Customary)
 - Part D — Properties (Metric)
- III Rules for Construction of Nuclear Facility Components
 - Subsection NCA — General Requirements for Division 1 and Division 2
 - Appendices
 - Division 1
 - Subsection NB — Class 1 Components
 - Subsection NCD — Class 2 and Class 3 Components*
 - Subsection NE — Class MC Components
 - Subsection NF — Supports
 - Subsection NG — Core Support Structures
 - Division 2 — Code for Concrete Containments
 - Division 3 — Containment Systems for Transportation and Storage of Spent Nuclear Fuel and High-Level Radioactive Material
 - Division 5 — High Temperature Reactors
- IV Rules for Construction of Heating Boilers
- V Nondestructive Examination
- VI Recommended Rules for the Care and Operation of Heating Boilers
- VII Recommended Guidelines for the Care of Power Boilers
- VIII Rules for Construction of Pressure Vessels
 - Division 1
 - Division 2 — Alternative Rules
 - Division 3 — Alternative Rules for Construction of High Pressure Vessels
- IX Welding, Brazing, and Fusing Qualifications
- X Fiber-Reinforced Plastic Pressure Vessels
- XI Rules for Inservice Inspection of Nuclear Power Plant Components
 - Division 1 — Rules for Inspection and Testing of Components of Light-Water-Cooled Plants
 - Division 2 — Requirements for Reliability and Integrity Management (RIM) Programs for Nuclear Power Plants
- XII Rules for Construction and Continued Service of Transport Tanks
- XIII Rules for Overpressure Protection

* In the 2021 Edition, Subsections NC and ND have been incorporated into one publication, Subsection NCD (BPVC.III.1.NCD), Class 2 and Class 3 Components.

INTERPRETATIONS

Interpretations are issued in real time in ASME's Interpretations Database at <http://go.asme.org/Interpretations>. Historical BPVC interpretations may also be found in the Database.

CODE CASES

The Boiler and Pressure Vessel Code committees meet regularly to consider proposed additions and revisions to the Code and to formulate Cases to clarify the intent of existing requirements or provide, when the need is urgent, rules for materials or constructions not covered by existing Code rules. Those Cases that have been adopted will appear in the appropriate 2021 Code Cases book: "Boilers and Pressure Vessels" or "Nuclear Components." Each Code Cases book is updated with seven Supplements. Supplements will be sent or made available automatically to the purchasers of the Code Cases books up to the publication of the 2023 Code. Annulments of Code Cases become effective six months after the first announcement of the annulment in a Code Case Supplement or Edition of the appropriate Code Case book. Code Case users can check the current status of any Code Case at <http://go.asme.org/BPVCCDatabase>. Code Case users can also view an index of the complete list of Boiler and Pressure Vessel Code Cases and Nuclear Code Cases at <http://go.asme.org/BPVCC>.

FOREWORD*

(21)

In 1911, The American Society of Mechanical Engineers established the Boiler and Pressure Vessel Committee to formulate standard rules for the construction of steam boilers and other pressure vessels. In 2009, the Boiler and Pressure Vessel Committee was superseded by the following committees:

- (a) Committee on Power Boilers (I)
- (b) Committee on Materials (II)
- (c) Committee on Construction of Nuclear Facility Components (III)
- (d) Committee on Heating Boilers (IV)
- (e) Committee on Nondestructive Examination (V)
- (f) Committee on Pressure Vessels (VIII)
- (g) Committee on Welding, Brazing, and Fusing (IX)
- (h) Committee on Fiber-Reinforced Plastic Pressure Vessels (X)
- (i) Committee on Nuclear Inservice Inspection (XI)
- (j) Committee on Transport Tanks (XII)
- (k) Committee on Overpressure Protection (XIII)
- (l) Technical Oversight Management Committee (TOMC)

Where reference is made to “the Committee” in this Foreword, each of these committees is included individually and collectively.

The Committee’s function is to establish rules of safety relating to pressure integrity, which govern the construction** of boilers, pressure vessels, transport tanks, and nuclear components, and the inservice inspection of nuclear components and transport tanks. For nuclear items other than pressure-retaining components, the Committee also establishes rules of safety related to structural integrity. The Committee also interprets these rules when questions arise regarding their intent. The technical consistency of the Sections of the Code and coordination of standards development activities of the Committees is supported and guided by the Technical Oversight Management Committee. This Code does not address other safety issues relating to the construction of boilers, pressure vessels, transport tanks, or nuclear components, or the inservice inspection of nuclear components or transport tanks. Users of the Code should refer to the pertinent codes, standards, laws, regulations, or other relevant documents for safety issues other than those relating to pressure integrity and, for nuclear items other than pressure-retaining components, structural integrity. Except for Sections XI and XII, and with a few other exceptions, the rules do not, of practical necessity, reflect the likelihood and consequences of deterioration in service related to specific service fluids or external operating environments. In formulating the rules, the Committee considers the needs of users, manufacturers, and inspectors of components addressed by the Code. The objective of the rules is to afford reasonably certain protection of life and property, and to provide a margin for deterioration in service to give a reasonably long, safe period of usefulness. Advancements in design and materials and evidence of experience have been recognized.

This Code contains mandatory requirements, specific prohibitions, and nonmandatory guidance for construction activities and inservice inspection and testing activities. The Code does not address all aspects of these activities and those aspects that are not specifically addressed should not be considered prohibited. The Code is not a handbook and cannot replace education, experience, and the use of engineering judgment. The phrase *engineering judgment* refers to technical judgments made by knowledgeable engineers experienced in the application of the Code. Engineering judgments must be consistent with Code philosophy, and such judgments must never be used to overrule mandatory requirements or specific prohibitions of the Code.

The Committee recognizes that tools and techniques used for design and analysis change as technology progresses and expects engineers to use good judgment in the application of these tools. The designer is responsible for complying with Code rules and demonstrating compliance with Code equations when such equations are mandatory. The Code neither requires nor prohibits the use of computers for the design or analysis of components constructed to the requirements of the Code. However, designers and engineers using computer programs for design or analysis are cautioned that they are

* The information contained in this Foreword is not part of this American National Standard (ANS) and has not been processed in accordance with ANSI’s requirements for an ANS. Therefore, this Foreword may contain material that has not been subjected to public review or a consensus process. In addition, it does not contain requirements necessary for conformance to the Code.

** *Construction*, as used in this Foreword, is an all-inclusive term comprising materials, design, fabrication, examination, inspection, testing, certification, and overpressure protection.

responsible for all technical assumptions inherent in the programs they use and the application of these programs to their design.

The rules established by the Committee are not to be interpreted as approving, recommending, or endorsing any proprietary or specific design, or as limiting in any way the manufacturer's freedom to choose any method of design or any form of construction that conforms to the Code rules.

The Committee meets regularly to consider revisions of the rules, new rules as dictated by technological development, Code Cases, and requests for interpretations. Only the Committee has the authority to provide official interpretations of this Code. Requests for revisions, new rules, Code Cases, or interpretations shall be addressed to the Secretary in writing and shall give full particulars in order to receive consideration and action (see Submittal of Technical Inquiries to the Boiler and Pressure Vessel Standards Committees). Proposed revisions to the Code resulting from inquiries will be presented to the Committee for appropriate action. The action of the Committee becomes effective only after confirmation by ballot of the Committee and approval by ASME. Proposed revisions to the Code approved by the Committee are submitted to the American National Standards Institute (ANSI) and published at <http://go.asme.org/BPVCPublicReview> to invite comments from all interested persons. After public review and final approval by ASME, revisions are published at regular intervals in Editions of the Code.

The Committee does not rule on whether a component shall or shall not be constructed to the provisions of the Code. The scope of each Section has been established to identify the components and parameters considered by the Committee in formulating the Code rules.

Questions or issues regarding compliance of a specific component with the Code rules are to be directed to the ASME Certificate Holder (Manufacturer). Inquiries concerning the interpretation of the Code are to be directed to the Committee. ASME is to be notified should questions arise concerning improper use of the ASME Single Certification Mark.

When required by context in this Section, the singular shall be interpreted as the plural, and vice versa, and the feminine, masculine, or neuter gender shall be treated as such other gender as appropriate.

The words "shall," "should," and "may" are used in this Standard as follows:

- *Shall* is used to denote a requirement.
- *Should* is used to denote a recommendation.
- *May* is used to denote permission, neither a requirement nor a recommendation.

STATEMENT OF POLICY ON THE USE OF THE ASME SINGLE CERTIFICATION MARK AND CODE AUTHORIZATION IN ADVERTISING

ASME has established procedures to authorize qualified organizations to perform various activities in accordance with the requirements of the ASME Boiler and Pressure Vessel Code. It is the aim of the Society to provide recognition of organizations so authorized. An organization holding authorization to perform various activities in accordance with the requirements of the Code may state this capability in its advertising literature.

Organizations that are authorized to use the ASME Single Certification Mark for marking items or constructions that have been constructed and inspected in compliance with the ASME Boiler and Pressure Vessel Code are issued Certificates of Authorization. It is the aim of the Society to maintain the standing of the ASME Single Certification Mark for the benefit of the users, the enforcement jurisdictions, and the holders of the ASME Single Certification Mark who comply with all requirements.

Based on these objectives, the following policy has been established on the usage in advertising of facsimiles of the ASME Single Certification Mark, Certificates of Authorization, and reference to Code construction. The American Society of Mechanical Engineers does not “approve,” “certify,” “rate,” or “endorse” any item, construction, or activity and there shall be no statements or implications that might so indicate. An organization holding the ASME Single Certification Mark and/or a Certificate of Authorization may state in advertising literature that items, constructions, or activities “are built (produced or performed) or activities conducted in accordance with the requirements of the ASME Boiler and Pressure Vessel Code,” or “meet the requirements of the ASME Boiler and Pressure Vessel Code.” An ASME corporate logo shall not be used by any organization other than ASME.

The ASME Single Certification Mark shall be used only for stamping and nameplates as specifically provided in the Code. However, facsimiles may be used for the purpose of fostering the use of such construction. Such usage may be by an association or a society, or by a holder of the ASME Single Certification Mark who may also use the facsimile in advertising to show that clearly specified items will carry the ASME Single Certification Mark.

STATEMENT OF POLICY ON THE USE OF ASME MARKING TO IDENTIFY MANUFACTURED ITEMS

The ASME Boiler and Pressure Vessel Code provides rules for the construction of boilers, pressure vessels, and nuclear components. This includes requirements for materials, design, fabrication, examination, inspection, and stamping. Items constructed in accordance with all of the applicable rules of the Code are identified with the ASME Single Certification Mark described in the governing Section of the Code.

Markings such as “ASME,” “ASME Standard,” or any other marking including “ASME” or the ASME Single Certification Mark shall not be used on any item that is not constructed in accordance with all of the applicable requirements of the Code.

Items shall not be described on ASME Data Report Forms nor on similar forms referring to ASME that tend to imply that all Code requirements have been met when, in fact, they have not been. Data Report Forms covering items not fully complying with ASME requirements should not refer to ASME or they should clearly identify all exceptions to the ASME requirements.

(21) **SUBMITTAL OF TECHNICAL INQUIRIES TO THE BOILER AND PRESSURE VESSEL STANDARDS COMMITTEES**

1 INTRODUCTION

(a) The following information provides guidance to Code users for submitting technical inquiries to the applicable Boiler and Pressure Vessel (BPV) Standards Committee (hereinafter referred to as the Committee). See the guidelines on approval of new materials under the ASME Boiler and Pressure Vessel Code in Section II, Part D for requirements for requests that involve adding new materials to the Code. See the guidelines on approval of new welding and brazing materials in Section II, Part C for requirements for requests that involve adding new welding and brazing materials (“consumables”) to the Code.

Technical inquiries can include requests for revisions or additions to the Code requirements, requests for Code Cases, or requests for Code Interpretations, as described below:

(1) *Code Revisions*. Code revisions are considered to accommodate technological developments, to address administrative requirements, to incorporate Code Cases, or to clarify Code intent.

(2) *Code Cases*. Code Cases represent alternatives or additions to existing Code requirements. Code Cases are written as a Question and Reply, and are usually intended to be incorporated into the Code at a later date. When used, Code Cases prescribe mandatory requirements in the same sense as the text of the Code. However, users are cautioned that not all regulators, jurisdictions, or Owners automatically accept Code Cases. The most common applications for Code Cases are as follows:

(-a) to permit early implementation of an approved Code revision based on an urgent need

(-b) to permit use of a new material for Code construction

(-c) to gain experience with new materials or alternative requirements prior to incorporation directly into the Code

(3) *Code Interpretations*

(-a) Code Interpretations provide clarification of the meaning of existing requirements in the Code and are presented in Inquiry and Reply format. Interpretations do not introduce new requirements.

(-b) Interpretations will be issued only if existing Code text is ambiguous or conveys conflicting requirements. If a revision of the requirements is required to support the Interpretation, an Intent Interpretation will be issued in parallel with a revision to the Code.

(b) Code requirements, Code Cases, and Code Interpretations established by the Committee are not to be considered as approving, recommending, certifying, or endorsing any proprietary or specific design, or as limiting in any way the freedom of manufacturers, constructors, or Owners to choose any method of design or any form of construction that conforms to the Code requirements.

(c) Inquiries that do not comply with the following guidance or that do not provide sufficient information for the Committee’s full understanding may result in the request being returned to the Inquirer with no action.

2 INQUIRY FORMAT

Submittals to the Committee should include the following information:

(a) *Purpose*. Specify one of the following:

(1) request for revision of present Code requirements

(2) request for new or additional Code requirements

(3) request for Code Case

(4) request for Code Interpretation

(b) *Background*. The Inquirer should provide the information needed for the Committee’s understanding of the Inquiry, being sure to include reference to the applicable Code Section, Division, Edition, Addenda (if applicable), paragraphs, figures, and tables. This information should include a statement indicating why the included paragraphs, figures, or tables are ambiguous or convey conflicting requirements. Preferably, the Inquirer should provide a copy of, or relevant extracts from, the specific referenced portions of the Code.

(c) *Presentations.* The Inquirer may desire to attend or be asked to attend a meeting of the Committee to make a formal presentation or to answer questions from the Committee members with regard to the Inquiry. Attendance at a BPV Standards Committee meeting shall be at the expense of the Inquirer. The Inquirer's attendance or lack of attendance at a meeting will not be used by the Committee as a basis for acceptance or rejection of the Inquiry by the Committee. However, if the Inquirer's request is unclear, attendance by the Inquirer or a representative may be necessary for the Committee to understand the request sufficiently to be able to provide an Interpretation. If the Inquirer desires to make a presentation at a Committee meeting, the Inquirer should provide advance notice to the Committee Secretary, to ensure time will be allotted for the presentation in the meeting agenda. The Inquirer should consider the need for additional audiovisual equipment that might not otherwise be provided by the Committee. With sufficient advance notice to the Committee Secretary, such equipment may be made available.

3 CODE REVISIONS OR ADDITIONS

Requests for Code revisions or additions should include the following information:

(a) *Requested Revisions or Additions.* For requested revisions, the Inquirer should identify those requirements of the Code that they believe should be revised, and should submit a copy of, or relevant extracts from, the appropriate requirements as they appear in the Code, marked up with the requested revision. For requested additions to the Code, the Inquirer should provide the recommended wording and should clearly indicate where they believe the additions should be located in the Code requirements.

(b) *Statement of Need.* The Inquirer should provide a brief explanation of the need for the revision or addition.

(c) *Background Information.* The Inquirer should provide background information to support the revision or addition, including any data or changes in technology that form the basis for the request, that will allow the Committee to adequately evaluate the requested revision or addition. Sketches, tables, figures, and graphs should be submitted, as appropriate. The Inquirer should identify any pertinent portions of the Code that would be affected by the revision or addition and any portions of the Code that reference the requested revised or added paragraphs.

4 CODE CASES

Requests for Code Cases should be accompanied by a statement of need and background information similar to that described in 3(b) and 3(c), respectively, for Code revisions or additions. The urgency of the Code Case (e.g., project underway or imminent, new procedure) should be described. In addition, it is important that the request is in connection with equipment that will bear the ASME Single Certification Mark, with the exception of Section XI applications. The proposed Code Case should identify the Code Section and Division, and should be written as a Question and a Reply, in the same format as existing Code Cases. Requests for Code Cases should also indicate the applicable Code Editions and Addenda (if applicable) to which the requested Code Case applies.

5 CODE INTERPRETATIONS

(a) Requests for Code Interpretations should be accompanied by the following information:

(1) *Inquiry.* The Inquirer should propose a condensed and precise Inquiry, omitting superfluous background information and, when possible, composing the Inquiry in such a way that a "yes" or a "no" Reply, with brief limitations or conditions, if needed, can be provided by the Committee. The proposed question should be technically and editorially correct.

(2) *Reply.* The Inquirer should propose a Reply that clearly and concisely answers the proposed Inquiry question. Preferably, the Reply should be "yes" or "no," with brief limitations or conditions, if needed.

(3) *Background Information.* The Inquirer should include a statement indicating why the included paragraphs, figures, or tables are ambiguous or convey conflicting requirements. The Inquirer should provide any need or background information, such as described in 3(b) and 3(c), respectively, for Code revisions or additions, that will assist the Committee in understanding the proposed Inquiry and Reply.

If the Inquirer believes a revision of the Code requirements would be helpful to support the Interpretation, the Inquirer may propose such a revision for consideration by the Committee. In most cases, such a proposal is not necessary.

(b) Requests for Code Interpretations should be limited to an Interpretation of a particular requirement in the Code or in a Code Case. Except with regard to interpreting a specific Code requirement, the Committee is not permitted to consider consulting-type requests such as the following:

(1) a review of calculations, design drawings, welding qualifications, or descriptions of equipment or parts to determine compliance with Code requirements

(2) a request for assistance in performing any Code-prescribed functions relating to, but not limited to, material selection, designs, calculations, fabrication, inspection, pressure testing, or installation

(3) a request seeking the rationale for Code requirements

6 SUBMITTALS

(a) *Submittal.* Requests for Code Interpretation should preferably be submitted through the online Interpretation Submittal Form. The form is accessible at <http://go.asme.org/InterpretationRequest>. Upon submittal of the form, the Inquirer will receive an automatic e-mail confirming receipt. If the Inquirer is unable to use the online form, the Inquirer may mail the request to the following address:

Secretary
ASME Boiler and Pressure Vessel Committee
Two Park Avenue
New York, NY 10016-5990

All other Inquiries should be mailed to the Secretary of the BPV Committee at the address above. Inquiries are unlikely to receive a response if they are not written in clear, legible English. They must also include the name of the Inquirer and the company they represent or are employed by, if applicable, and the Inquirer's address, telephone number, fax number, and e-mail address, if available.

(b) *Response.* The Secretary of the appropriate Committee will provide a written response, via letter or e-mail, as appropriate, to the Inquirer, upon completion of the requested action by the Committee. Inquirers may track the status of their Interpretation Request at <http://go.asme.org/Interpretations>.

PERSONNEL

ASME Boiler and Pressure Vessel Standards Committees, Subgroups, and Working Groups

(21)

January 1, 2021

TECHNICAL OVERSIGHT MANAGEMENT COMMITTEE (TOMC)

R. E. McLaughlin, <i>Chair</i>	J. F. Henry
N. A. Finney, <i>Vice Chair</i>	R. B. Keating
S. J. Rossi, <i>Staff Secretary</i>	B. Linnemann
G. Auriolos, Sr.	W. M. Lundy
R. W. Barnes	D. I. Morris
T. L. Bedeaux	T. P. Pastor
D. A. Bowers	M. D. Rana
C. Brown	S. C. Roberts
D. B. DeMichael	F. J. Schaaf, Jr.
R. P. Deubler	G. Scribner
P. D. Edwards	W. J. Sperko
J. G. Feldstein	D. Srnic
G. W. Galanes	R. W. Swayne
J. A. Hall	M. Wadkinson
T. E. Hansen	J. E. Batey, <i>Contributing Member</i>
G. W. Hembree	

Subgroup on Research and Development (TOMC)

S. C. Roberts, <i>Chair</i>	B. Hrubala
S. J. Rossi, <i>Staff Secretary</i>	R. B. Keating
R. W. Barnes	R. E. McLaughlin
N. A. Finney	T. P. Pastor
J. F. Henry	D. Andrei, <i>Contributing Member</i>
W. Hoffelner	

Subgroup on Strategic Initiatives (TOMC)

N. A. Finney, <i>Chair</i>	M. H. Jawad
S. J. Rossi, <i>Staff Secretary</i>	R. B. Keating
R. W. Barnes	R. E. McLaughlin
T. L. Bedeaux	T. P. Pastor
G. W. Hembree	S. C. Roberts
J. F. Henry	

Task Group on Remote Inspection and Examination (SI-TOMC)

S. C. Roberts, <i>Chair</i>	M. Tannenbaum
P. J. Coco	J. Cameron, <i>Alternate</i>
N. A. Finney	P. Lang, <i>Contributing Member</i>
S. A. Marks	J. Pang, <i>Contributing Member</i>
R. Rockwood	S. J. Rossi, <i>Contributing Member</i>
C. Stevens	C. A. Sanna, <i>Contributing Member</i>

Special Working Group on High Temperature Technology (TOMC)

D. Dewees, <i>Chair</i>	B. F. Hantz
F. W. Brust	J. F. Henry
T. D. Burchell	R. I. Jetter
P. R. Donavin	P. Smith

ADMINISTRATIVE COMMITTEE

R. E. McLaughlin, <i>Chair</i>	R. B. Keating
N. A. Finney, <i>Vice Chair</i>	B. Linnemann
S. J. Rossi, <i>Staff Secretary</i>	M. D. Rana
D. A. Bowers	S. C. Roberts
J. Cameron	R. R. Stevenson
D. B. DeMichael	R. W. Swayne
J. A. Hall	

MARINE CONFERENCE GROUP

E. Lawson, <i>Staff Secretary</i>	H. N. Patel
J. G. Hungerbuhler, Jr.	N. Prokopuk
G. Nair	J. D. Reynolds

CONFERENCE COMMITTEE

C. B. Cantrell — Nebraska, <i>Chair</i>	A. M. Lorimor — South Dakota
J. T. Amato — Ohio, <i>Secretary</i>	M. Mailman — Northwest Territories, Canada
W. Anderson — Mississippi	W. McGivney — City of New York, New York
P. Bearden — Minnesota	S. F. Noonan — Maryland
R. Becker — Colorado	A. K. Oda — Washington
T. D. Boggs — Missouri	B. S. Oliver — New Hampshire
R. A. Boillard — Indiana	J. L. Oliver — Nevada
R. J. Bunte — Iowa	M. Poehlmann — Alberta, Canada
J. H. Burpee — Maine	P. B. Polick — Illinois
S. Chapman — Tennessee	J. F. Porcella — West Virginia
T. G. Clark — Oregon	C. F. Reyes — California
B. J. Crawford — Georgia	W. J. Ross — Pennsylvania
E. L. Creaser — New Brunswick, Canada	M. J. Ryan — City of Chicago, Illinois
J. J. Dacanay — Hawaii	M. H. Sansone — New York
R. DeLury — Manitoba, Canada	T. S. Seime — North Dakota
C. Dinic — Ontario, Canada	C. S. Selinger — Saskatchewan, Canada
D. Eastman — Newfoundland and Labrador, Canada	J. E. Sharier — Ohio
D. A. Ehler — Nova Scotia, Canada	R. Spiker — North Carolina
S. D. Frazier — Washington	D. J. Stenrose — Michigan
T. J. Granneman II — Oklahoma	R. J. Stimson II — Kansas
S. Harder — Arizona	R. K. Sturm — Utah
E. G. Hilton — Virginia	D. K. Sullivan — Arkansas
M. L. Jordan — Kentucky	J. Taveras — Rhode Island
R. Kamboj — British Columbia, Canada	G. Teel — California
E. Kawa, Jr. — Massachusetts	S. R. Townsend — Prince Edward Island, Canada
A. Khssassi — Quebec, Canada	R. D. Trout — Texas
D. Kinney — North Carolina	D. M. Warburton — Florida
J. Klug — City of Milwaukee, Wisconsin	M. Washington — New Jersey
K. S. Lane — Alaska	E. Wiggins — Alabama
J. LeSage, Jr. — Louisiana	

INTERNATIONAL INTEREST REVIEW GROUP

V. Felix
Y.-G. Kim
S. H. Leong
W. Lin
O. F. Manafa

C. Minu
Y.-W. Park
A. R. Reynaga Nogales
P. Williamson

COMMITTEE ON POWER BOILERS (BPV I)

R. E. McLaughlin, *Chair*
E. M. Ortman, *Vice Chair*
U. D'Urso, *Staff Secretary*
D. I. Anderson
J. L. Arnold
K. K. Coleman
P. D. Edwards
J. G. Feldstein
S. Fincher
G. W. Galanes
T. E. Hansen
J. F. Henry
J. S. Hunter
M. Ishikawa
G. B. Komora
F. Massi
L. Moedinger
P. A. Molvie
Y. Oishi

D. E. Tompkins
D. E. Tuttle
J. Vattappilly
M. Wadkinson
R. V. Wielgoszinski
F. Zeller
H. Michael, *Delegate*
D. L. Berger, *Honorary Member*
D. N. French, *Honorary Member*
J. Hainsworth, *Honorary Member*
W. L. Lowry, *Honorary Member*
J. R. MacKay, *Honorary Member*
T. C. McGough, *Honorary Member*
J. T. Pillow, *Honorary Member*
B. W. Roberts, *Honorary Member*
R. D. Schueler, Jr., *Honorary Member*
J. M. Tanzosh, *Honorary Member*
R. L. Williams, *Honorary Member*
L. W. Yoder, *Honorary Member*

Executive Committee (BPV I)

E. M. Ortman, *Chair*
R. E. McLaughlin, *Vice Chair*
D. I. Anderson
J. L. Arnold
J. R. Braun
K. K. Coleman
H. Dalal

T. Dhanraj
U. D'Urso
P. F. Gilston
K. Hayes
P. Jennings
A. Spangenberg
D. E. Tompkins

Subgroup on Design (BPV I)

D. I. Anderson, *Chair*
L. S. Tsai, *Secretary*
P. Becker
D. Dewees
G. B. Komora
L. Krupp

P. A. Molvie
N. Ranck
J. Vattappilly
M. Wadkinson
J. P. Glaspie, *Contributing Member*

Subgroup on Fabrication and Examination (BPV I)

J. L. Arnold, *Chair*
P. F. Gilston, *Vice Chair*
P. Becker, *Secretary*
A. Biesecker
K. K. Coleman
S. Fincher
G. W. Galanes
T. E. Hansen

P. Jennings
M. Lewis
C. T. McDaris
R. E. McLaughlin
R. J. Newell
Y. Oishi
R. V. Wielgoszinski

Subgroup on General Requirements and Piping (BPV I)

E. M. Ortman, *Chair*
D. E. Tompkins, *Vice Chair*
F. Massi, *Secretary*
P. D. Edwards
T. E. Hansen
M. Ishikawa
M. Lemmons
R. E. McLaughlin

L. Moedinger
B. J. Mollitor
Y. Oishi
D. E. Tuttle
M. Wadkinson
R. V. Wielgoszinski
W. L. Lowry, *Contributing Member*

Subgroup on Locomotive Boilers (BPV I)

J. R. Braun, *Chair*
S. M. Butler, *Secretary*
A. Biesecker
C. Cross
G. W. Galanes
D. W. Griner

M. A. Janssen
S. A. Lee
L. Moedinger
G. M. Ray
M. W. Westland

Subgroup on Materials (BPV I)

K. K. Coleman, *Chair*
K. Hayes, *Vice Chair*
M. Lewis, *Secretary*
S. H. Bowes
G. W. Galanes
P. F. Gilston
J. F. Henry
J. S. Hunter

E. Liebl
F. Masuyama
M. Ortolani
D. W. Raho
J. Vattappilly
F. Zeller
B. W. Roberts, *Contributing Member*
J. M. Tanzosh, *Contributing Member*

Subgroup on Solar Boilers (BPV I)

P. Jennings, *Chair*
R. E. Hearne, *Secretary*
S. Fincher

J. S. Hunter
F. Massi
P. Swarnkar

Task Group on Modernization (BPV I)

D. I. Anderson, *Chair*
U. D'Urso, *Staff Secretary*
J. L. Arnold
D. Dewees
G. W. Galanes
J. P. Glaspie
T. E. Hansen

J. F. Henry
R. E. McLaughlin
P. A. Molvie
E. M. Ortman
D. E. Tuttle
J. Vattappilly

Germany International Working Group (BPV I)

A. Spangenberg, *Chair*
P. Chavdarov, *Secretary*
B. Daume
J. Fleischfresser
R. Kauer
D. Koelbl
S. Krebs
T. Ludwig
R. A. Meyers
H. Michael

F. Miunske
M. Sykora
R. Helmholdt, *Contributing Member*
J. Henrichsmeyer, *Contributing Member*
B. Müller, *Contributing Member*
P. Paluszkiwicz, *Contributing Member*
R. Uebel, *Contributing Member*

India International Working Group (BPV I)

H. Dalal, <i>Chair</i>	S. Purkait
T. Dhanraj, <i>Vice Chair</i>	M. G. Rao
K. Thanupillai, <i>Secretary</i>	U. Revisankaran
P. Brahma	G. U. Shanker
S. Chakrabarti	D. K. Shrivastava
A. Hantodkar	K. Singha
S. A. Kumar	R. Sundararaj
A. J. Patil	S. Venkataramana
A. R. Patil	

Subgroup on Ferrous Specifications (BPV II)

A. Appleton, <i>Chair</i>	J. Gundlach
K. M. Hottle, <i>Vice Chair</i>	D. S. Janikowski
C. Hyde, <i>Secretary</i>	S. G. Lee
B. M. Dingman	W. C. Mack
M. J. Dosedourian	K. E. Orié
O. Elkadim	D. Poweleit
D. Fialkowski	E. Upitis
J. F. Grubb	J. D. Fritz, <i>Contributing Member</i>

COMMITTEE ON MATERIALS (BPV II)

J. Cameron, <i>Chair</i>	A. Chaudouet, <i>Contributing Member</i>
J. F. Grubb, <i>Vice Chair</i>	D. B. Denis, <i>Contributing Member</i>
C. E. O'Brien, <i>Staff Secretary</i>	J. D. Fritz, <i>Contributing Member</i>
A. Appleton	W. Hoffelner, <i>Contributing Member</i>
P. Chavdarov	M. Katcher, <i>Contributing Member</i>
J. R. Foulds	R. K. Nanstad, <i>Contributing Member</i>
D. W. Gandy	M. L. Nayyar, <i>Contributing Member</i>
J. A. Hall	D. T. Peters, <i>Contributing Member</i>
J. F. Henry	B. W. Roberts, <i>Contributing Member</i>
K. M. Hottle	J. J. Sanchez-Hanton, <i>Contributing Member</i>
M. Ishikawa	R. W. Swindeman, <i>Contributing Member</i>
K. Kimura	J. M. Tanzosh, <i>Contributing Member</i>
F. Masuyama	E. Upitis, <i>Contributing Member</i>
K. E. Orié	R. G. Young, <i>Contributing Member</i>
D. W. Rahoi	T. M. Cullen, <i>Honorary Member</i>
W. Ren	W. D. Edsall, <i>Honorary Member</i>
E. Shapiro	G. C. Hsu, <i>Honorary Member</i>
R. C. Sutherland	C. E. Spaeder, Jr., <i>Honorary Member</i>
F. Zeller	A. W. Zeuthen, <i>Honorary Member</i>
O. Oldani, <i>Delegate</i>	
F. Abe, <i>Contributing Member</i>	

Subgroup on International Material Specifications (BPV II)

M. Ishikawa, <i>Chair</i>	W. M. Lundy
A. R. Nywening, <i>Vice Chair</i>	F. Zeller
B. Mruk, <i>Secretary</i>	C. Zhou
A. Chaudouet	O. Oldani, <i>Delegate</i>
P. Chavdarov	H. Lorenz, <i>Contributing Member</i>
H. Chen	T. F. Miskell, <i>Contributing Member</i>
A. F. Garbolevsky	E. Upitis, <i>Contributing Member</i>
D. O. Henry	

Subgroup on Nonferrous Alloys (BPV II)

E. Shapiro, <i>Chair</i>	D. W. Rahoi
S. Yem, <i>Vice Chair</i>	W. Ren
J. Robertson, <i>Secretary</i>	R. C. Sutherland
R. M. Beldyk	J. Weritz
J. M. Downs	A. Williams
J. F. Grubb	R. Wright
W. MacDonald	D. B. Denis, <i>Contributing Member</i>
D. Maitra	M. Katcher, <i>Contributing Member</i>
J. A. McMaster	D. T. Peters, <i>Contributing Member</i>

Executive Committee (BPV II)

J. Cameron, <i>Chair</i>	M. Ishikawa
C. E. O'Brien, <i>Staff Secretary</i>	D. L. Kurle
A. Appleton	R. W. Mikitka
G. W. Galanes	E. Shapiro
J. F. Grubb	R. C. Sutherland
J. F. Henry	

Subgroup on Physical Properties (BPV II)

J. F. Grubb, <i>Chair</i>	P. K. Lam
P. K. Rai, <i>Vice Chair</i>	S. Neilsen
G. Aurióles, Sr.	D. W. Rahoi
D. Chandiramani	E. Shapiro
P. Chavdarov	D. K. Verma
H. Eshraghi	S. Yem
B. F. Hantz	D. B. Denis, <i>Contributing Member</i>
R. D. Jones	

Subgroup on External Pressure (BPV II)

D. L. Kurle, <i>Chair</i>	J. F. Grubb
S. Guzey, <i>Vice Chair</i>	M. H. Jawad
J. A. A. Morrow, <i>Secretary</i>	S. Krishnamurthy
E. Alexis	R. W. Mikitka
L. F. Campbell	P. K. Rai
H. Chen	M. Wadkinson
D. S. Griffin	M. Katcher, <i>Contributing Member</i>

Subgroup on Strength, Ferrous Alloys (BPV II)

S. W. Knowles, <i>Vice Chair</i>	M. Osterfoss
L. S. Nicol, <i>Secretary</i>	D. W. Rahoi
J. R. Foulds	S. Rosinski
G. W. Galanes	M. Ueyama
J. A. Hall	F. Zeller
J. F. Henry	F. Abe, <i>Contributing Member</i>
M. Ishikawa	A. Di Rienzo, <i>Contributing Member</i>
F. Masuyama	M. Nair, <i>Contributing Member</i>
M. Ortolani	R. G. Young, <i>Contributing Member</i>

Subgroup on Strength of Weldments (BPV II & BPV IX)

G. W. Galanes, <i>Chair</i>	J. Penso
K. L. Hayes, <i>Vice Chair</i>	D. W. Rahoi
S. H. Bowes, <i>Secretary</i>	B. W. Roberts
K. K. Coleman	W. J. Sperko
M. Denault	J. P. Swezy, Jr.
J. R. Foulds	M. Ueyama
D. W. Gandy	P. D. Flenner, <i>Contributing Member</i>
M. Ghahremani	J. J. Sanchez-Hanton, <i>Contributing Member</i>
J. F. Henry	
W. F. Newell, Jr.	

Working Group on Materials Database (BPV II)

W. Hoeffelner, <i>Vice Chair</i>	J. L. Arnold, <i>Contributing Member</i>
C. E. O'Brien, <i>Staff Secretary</i>	D. T. Peters, <i>Contributing Member</i>
F. Abe	W. Ren, <i>Contributing Member</i>
J. R. Foulds	B. W. Roberts, <i>Contributing Member</i>
J. F. Henry	R. W. Swindeman, <i>Contributing Member</i>
R. C. Sutherlin	
D. Andrei, <i>Contributing Member</i>	

Working Group on Creep Strength Enhanced Ferritic Steels (BPV II)

M. Ortolani, <i>Chair</i>	J. J. Sanchez-Hanton
G. W. Galanes, <i>Vice Chair</i>	J. A. Siefert
S. H. Bowes	W. J. Sperko
K. K. Coleman	F. Zeller
J. R. Foulds	F. Abe, <i>Contributing Member</i>
J. F. Henry	G. Cumino, <i>Contributing Member</i>
M. Lang	P. D. Flenner, <i>Contributing Member</i>
S. Luke	R. W. Swindeman, <i>Contributing Member</i>
F. Masuyama	
T. Melfi	J. M. Tanzosh, <i>Contributing Member</i>
W. F. Newell, Jr.	

Working Group on Data Analysis (BPV II)

J. F. Grubb, <i>Chair</i>	F. Abe, <i>Contributing Member</i>
J. R. Foulds, <i>Vice Chair</i>	W. Hoeffelner, <i>Contributing Member</i>
J. F. Henry	M. Katcher, <i>Contributing Member</i>
F. Masuyama	D. T. Peters, <i>Contributing Member</i>
M. Ortolani	B. W. Roberts, <i>Contributing Member</i>
W. Ren	R. W. Swindeman, <i>Contributing Member</i>
M. Subanovic	
M. J. Swindeman	

China International Working Group (BPV II)

S. Liu, <i>Chair</i>	Q.-J. Wang
Yong Zhang, <i>Vice Chair</i>	X. Wang
A. T. Xu, <i>Secretary</i>	F. Yang
W. Fang	G. Yang
Q. C. Feng	H.-C. Yang
S. Huo	J. Yang
F. Kong	R. Ye
H. Li	L. Yin
J. Li	H. Zhang
S. Li	X.-H. Zhang
Z. Rongcan	Yingkai Zhang
S. Tan	Q. Zhao
C. Wang	S. Zhao
J. Wang	

COMMITTEE ON CONSTRUCTION OF NUCLEAR FACILITY COMPONENTS (BPV III)

R. B. Keating, <i>Chair</i>	M. A. Lockwood
T. M. Adams, <i>Vice Chair</i>	K. A. Manoly
D. E. Matthews, <i>Vice Chair</i>	K. Matsunaga
K. Verderber, <i>Staff Secretary</i>	B. McGlone
A. Appleton	S. McKillop
S. Asada	J. C. Minichiello
R. W. Barnes	M. N. Mitchell
W. H. Borter	T. Nagata
M. E. Cohen	J. B. Ossmann
R. P. Deubler	S. Pellet
P. R. Donavin	E. L. Pleins
A. C. Eberhardt	S. Sham
J. V. Gardiner	W. J. Sperko
J. Grimm	C. T. Smith, <i>Contributing Member</i>
S. Hunter	W. K. Sowder, Jr., <i>Contributing Member</i>
R. M. Jessee	M. Zhou, <i>Contributing Member</i>
R. I. Jetter	D. K. Morton, <i>Honorary Member</i>
C. C. Kim	R. F. Reedy, Sr., <i>Honorary Member</i>
G. H. Koo	
V. Kostarev	

Executive Committee (BPV III)

R. B. Keating, <i>Chair</i>	D. E. Matthews
K. Verderber, <i>Staff Secretary</i>	S. McKillop
T. M. Adams	J. A. Munshi
P. R. Donavin	S. Sham
J. V. Gardiner	W. K. Sowder, Jr.
J. Grimm	

Subcommittee on Design (BPV III)

P. R. Donavin, <i>Chair</i>	M. N. Mitchell
R. P. Deubler	S. Sham
M. A. Gray	W. F. Weitze
R. I. Jetter	G. L. Hollinger, <i>Contributing Member</i>
R. B. Keating	M. H. Jawad, <i>Contributing Member</i>
K. A. Manoly	W. J. O'Donnell, Sr., <i>Contributing Member</i>
D. E. Matthews	K. Wright, <i>Contributing Member</i>
S. McKillop	

Subgroup on Component Design (SC-D) (BPV III)

D. E. Matthews, <i>Chair</i>	K. A. Manoly
P. Vock, <i>Vice Chair</i>	R. J. Masterson
S. Pellet, <i>Secretary</i>	J. C. Minichiello
T. M. Adams	T. Mitsuhashi
D. J. Ammerman	D. Murphy
G. A. Antaki	T. M. Musto
S. Asada	T. Nagata
J. F. Ball	J. R. Stinson
C. Basavaraju	G. Z. Tokarski
D. Chowdhury	J. P. Tucker
R. P. Deubler	S. Willoughby-Braun
P. Hirschberg	C. Wilson
M. Kassab	A. A. Dermenjian, <i>Contributing Member</i>
R. B. Keating	I. Saito, <i>Contributing Member</i>
D. Keck	K. R. Wichman, <i>Honorary Member</i>
O.-S. Kim	
T. R. Liszkai	

Working Group on Core Support Structures (SG-CD) (BPV III)

D. Keck, <i>Chair</i>	M. D. Snyder
R. Z. Ziegler, <i>Vice Chair</i>	R. Vollmer
R. Martin, <i>Secretary</i>	T. M. Wiger
G. W. Delpont	C. Wilson
L. C. Hartless	Y. Wong
T. R. Liszkai	A. Tsirigotis, <i>Alternate</i>
H. S. Mehta	J. F. Kielb, <i>Contributing Member</i>
M. Nakajima	

Working Group on Pumps (SG-CD) (BPV III)

D. Chowdhury, <i>Chair</i>	J. Sulley
J. V. Gregg, Jr., <i>Secretary</i>	A. G. Washburn
M. D. Eftychiou	Y. Wong
R. A. Fleming	I. H. Tseng, <i>Alternate</i>
S. Hughes	X. Di, <i>Contributing Member</i>
J. Kikushima	C. Gabhart, <i>Contributing Member</i>
K. J. Noel	R. Ladefian, <i>Contributing Member</i>

Working Group on Design of Division 3 Containment Systems (SG-CD) (BPV III)

D. J. Ammerman, <i>Chair</i>	D. Siromani
S. Klein, <i>Secretary</i>	X. Zhai
V. Broz	X. Zhang
D. W. Lewis	J. C. Minichiello, <i>Contributing Member</i>
A. Rigato	

Working Group on Supports (SG-CD) (BPV III)

J. R. Stinson, <i>Chair</i>	S. Pellet
U. S. Bandyopadhyay, <i>Secretary</i>	G. Z. Tokarski
K. Avrithi	A. Tsirigotis
F. J. Birch	L. Vandersip
N. M. Bisceglia	P. Wiseman
R. P. Deubler	J. Huang, <i>Alternate</i>
N. M. Graham	R. J. Masterson, <i>Contributing Member</i>
Y. Matsubara	

Working Group on HDPE Design of Components (SG-CD) (BPV III)

T. M. Musto, <i>Chair</i>	D. P. Munson
J. B. Ossmann, <i>Secretary</i>	F. J. Schaaf, Jr.
M. Brandes	R. Stakenborghs
S. Choi	J. Wright
J. R. Hebeisen	M. T. Audrain, <i>Alternate</i>
P. Krishnaswamy	D. Burwell, <i>Contributing Member</i>
M. Kuntz	J. C. Minichiello, <i>Contributing Member</i>
K. A. Manoly	
M. Martin	

Working Group on Valves (SG-CD) (BPV III)

P. Vock, <i>Chair</i>	C. A. Mizer
S. Jones, <i>Secretary</i>	H. O'Brien
M. C. Buckley	J. O'Callaghan
A. Cardillo	K. E. Reid II
R. Farrell	J. Sulley
G. A. Jolly	I. H. Tseng
J. Lambin	J. P. Tucker
T. Lippucci	N. J. Hansing, <i>Alternate</i>

Working Group on Piping (SG-CD) (BPV III)

G. A. Antaki, <i>Chair</i>	J. F. McCabe
G. Z. Tokarski, <i>Secretary</i>	I.-K. Nam
C. Basavaraju	J. O'Callaghan
J. Catalano	K. E. Reid II
F. Claeys	N. C. Sutherland
C. M. Faigy	D. Vlaicu
R. Farrell	S. Weindorf
R. G. Gilada	C.-I. Wu
N. M. Graham	T. M. Adams, <i>Contributing Member</i>
M. A. Gray	R. J. Gurdal, <i>Contributing Member</i>
R. W. Haupt	R. B. Keating, <i>Contributing Member</i>
A. Hirano	Y. Liu, <i>Contributing Member</i>
P. Hirschberg	J. C. Minichiello, <i>Contributing Member</i>
M. Kassab	
J. Kawahata	A. N. Nguyen, <i>Contributing Member</i>
V. Kostarev	M. S. Sills, <i>Contributing Member</i>
D. Lieb	E. A. Wais, <i>Contributing Member</i>
T. B. Littleton	

Working Group on Vessels (SG-CD) (BPV III)

D. Murphy, <i>Chair</i>	M. C. Scott
S. Willoughby-Braun, <i>Secretary</i>	P. K. Shah
J. Arthur	C. Turylo
C. Basavaraju	D. Vlaicu
D. Keck	C. Wilson
J. I. Kim	T. Yamazaki
O.-S. Kim	R. Z. Ziegler
D. E. Matthews	B. Basu, <i>Contributing Member</i>
T. Mitsuhashi	R. B. Keating, <i>Contributing Member</i>
T. J. Schriefer	W. F. Weitze, <i>Contributing Member</i>

Working Group on Pressure Relief (SG-CD) (BPV III)

J. F. Ball, <i>Chair</i>	I. H. Tseng
K. R. May, <i>Vice Chair</i>	J. Yu
R. Krithivasan, <i>Secretary</i>	N. J. Hansing, <i>Alternate</i>
J. W. Dickson	J. M. Levy, <i>Alternate</i>
S. Jones	B. J. Yonsky, <i>Alternate</i>
R. Lack	S. T. French, <i>Contributing Member</i>
D. Miller	D. B. Ross, <i>Contributing Member</i>
T. Patel	S. Ruesenberg, <i>Contributing Member</i>
K. Shores	

Subgroup on Design Methods (SC-D) (BPV III)

S. McKillop, <i>Chair</i>	J. I. Kim
P. R. Donavin, <i>Vice Chair</i>	W. J. O'Donnell, Sr.
J. Wen, <i>Secretary</i>	W. D. Reinhardt
K. Avrithi	P. Smith
L. Davies	S. D. Snow
R. Farrell	R. Vollmer
S. R. Gosselin	W. F. Weitze
M. A. Gray	T. M. Adams, <i>Contributing Member</i>
J. V. Gregg, Jr.	C. W. Bruny, <i>Contributing Member</i>
K. Hsu	H. T. Harrison III, <i>Contributing Member</i>
R. Kalnas	
D. Keck	K. Wright, <i>Contributing Member</i>

Working Group on Design Methodology (SG-DM) (BPV III)

R. Farrell, <i>Chair</i>	W. F. Weitze
R. Vollmer, <i>Secretary</i>	J. Wen
K. Avriithi	T. M. Wiger
C. Basavaraju	G. Banyay, <i>Contributing Member</i>
C. M. Faidy	D. S. S. Bartran, <i>Contributing Member</i>
C. F. Heberling II	
M. Kassar	R. D. Blevins, <i>Contributing Member</i>
J. I. Kim	M. R. Breach, <i>Contributing Member</i>
T. R. Liszkai	C. W. Bruny, <i>Contributing Member</i>
K. Matsunaga	D. L. Caldwell, <i>Contributing Member</i>
S. McKillop	H. T. Harrison III, <i>Contributing Member</i>
B. Pellereau	
S. Ranganath	P. Hirschberg, <i>Contributing Member</i>
W. D. Reinhardt	R. B. Keating, <i>Contributing Member</i>
P. K. Shah	A. Walker, <i>Contributing Member</i>
S. D. Snow	K. Wright, <i>Contributing Member</i>
S. Wang	

Working Group on Environmental Fatigue Evaluation Methods (SG-DM) (BPV III)

M. A. Gray, <i>Chair</i>	P. Hirschberg
W. F. Weitze, <i>Secretary</i>	H. S. Mehta
S. Asada	J.-S. Park
K. Avriithi	B. Pellereau
R. C. Cipolla	G. L. Stevens
T. M. Damiani	D. Vlaicu
C. M. Faidy	K. Wang
T. D. Gilman	R. Z. Ziegler
S. R. Gosselin	S. Cuvilliez, <i>Contributing Member</i>
Y. He	K. Wright, <i>Contributing Member</i>
A. Hirano	

Working Group on Fatigue Strength (SG-DM) (BPV III)

P. R. Donavin, <i>Chair</i>	S. H. Kleinsmith
M. S. Shelton, <i>Secretary</i>	H. S. Mehta
T. M. Damiani	B. Pellereau
D. W. DeJohn	S. Ranganath
C. M. Faidy	G. L. Stevens
P. Gill	Y. Wang
S. R. Gosselin	W. F. Weitze
R. J. Gurdal	Y. Zou
C. F. Heberling II	D. Dewees, <i>Contributing Member</i>
C. E. Hinnant	S. Majumdar, <i>Contributing Member</i>
P. Hirschberg	W. J. O'Donnell, Sr., <i>Contributing Member</i>
K. Hsu	
J. I. Kim	K. Wright, <i>Contributing Member</i>

Working Group on Probabilistic Methods in Design (SG-DM) (BPV III)

M. Golliet, <i>Chair</i>	D. O. Henry
R. Kalnas, <i>Vice Chair</i>	A. Hirano
T. Asayama	A. Martin
K. Avriithi	P. J. O'Regan
G. Brouette	B. Pellereau
J. Hakii	R. S. Hill III, <i>Contributing Member</i>

Special Working Group on Computational Modeling for Explicit Dynamics (SG-DM) (BPV III)

D. J. Ammerman, <i>Vice Chair</i>	P. Y.-K. Shih
V. Broz, <i>Secretary</i>	S. D. Snow
J. M. Jordan	C.-F. Tso
S. Kuehner	M. C. Yaksh
D. Molitoris	U. Zencker
W. D. Reinhardt	

Working Group on Allowable Stress Criteria (SG-HTR) (BPV III)

R. Wright, <i>Chair</i>	R. Rupp
M. McMurtrey, <i>Secretary</i>	S. Sham
K. Kimura	Y. Wang
D. Maitra	X. Wei
R. J. McReynolds	J. R. Foulds, <i>Contributing Member</i>
M. C. Messner	R. W. Swindeman, <i>Contributing Member</i>
W. Ren	

Working Group on Analysis Methods (SG-HTR) (BPV III)

M. C. Messner, <i>Chair</i>	S. Sham
R. W. Barnes	X. Wei
J. A. Blanco	S. X. Xu
P. Carter	T. Hassan, <i>Contributing Member</i>
M. E. Cohen	S. Krishnamurthy, <i>Contributing Member</i>
R. I. Jetter	
G. H. Koo	M. J. Swindeman, <i>Contributing Member</i>
H. Qian	

Working Group on Creep-Fatigue and Negligible Creep (SG-HTR) (BPV III)

S. Sham, <i>Chair</i>	G. H. Koo
Y. Wang, <i>Secretary</i>	M. McMurtrey
M. Ando	M. C. Messner
F. W. Brust	J. C. Poehler
P. Carter	H. Qian
M. E. Cohen	X. Wei
R. I. Jetter	

Working Group on High Temperature Flaw Evaluation (SG-HTR) (BPV III)

F. W. Brust, <i>Chair</i>	H. Qian
P. Carter	P. J. Rush
S. Kalyanam	C. J. Sallaberry
B.-L. Lyow	D. J. Shim
M. C. Messner	X. Wei
J. C. Poehler	S. X. Xu

Subgroup on General Requirements (BPV III)

J. V. Gardiner, <i>Chair</i>	E. C. Renaud
N. DeSantis, <i>Secretary</i>	T. N. Rezk
V. Apostolescu	J. Rogers
A. Appleton	D. J. Roszman
S. Bell	R. Spuhl
J. R. Berry	G. E. Szabatura
G. Brouette	D. M. Vickery
G. C. Deleanu	J. DeKleine, <i>Contributing Member</i>
J. W. Highlands	H. Michael, <i>Contributing Member</i>
E. V. Imbro	C. T. Smith, <i>Contributing Member</i>
K. A. Kavanagh	W. K. Sowder, Jr., <i>Contributing Member</i>
Y.-S. Kim	
B. McGlone	

Working Group on General Requirements (SG-GR) (BPV III)

B. McGlone, <i>Chair</i>	K. A. Kavanagh
J. Grimm, <i>Secretary</i>	Y.-S. Kim
V. Apostolescu	D. T. Meisch
A. Appleton	R. B. Patel
S. Bell	E. C. Renaud
J. R. Berry	T. N. Rezk
G. Brouette	J. Rogers
J. Carter	D. J. Roszman
P. J. Coco	B. S. Sandhu
N. DeSantis	R. Spuhl
Y. Diaz-Castillo	J. F. Strunk
O. Elkadim	G. E. Szabatura
J. V. Gardiner	D. M. Vickery
S. M. Goodwin	J. L. Williams
J. Harris	J. DeKleine, <i>Contributing Member</i>
J. W. Highlands	S. F. Harrison, Jr., <i>Contributing Member</i>
E. V. Imbro	

Special Working Group on General Requirements Consolidation (SG-GR) (BPV III)

J. V. Gardiner, <i>Chair</i>	R. B. Patel
J. Grimm, <i>Vice Chair</i>	E. C. Renaud
C. T. Smith, <i>Vice Chair</i>	R. Spuhl
Y. Diaz-Castillo	J. L. Williams

Working Group on General Requirements for Graphite and Ceramic Composite Core Components and Assemblies (SG-GR) (BPV III)

A. Appleton, <i>Chair</i>	M. N. Mitchell
W. J. Geringer, <i>Secretary</i>	E. C. Renaud
J. R. Berry	W. Windes
Y. Diaz-Castillo	

Subgroup on Materials, Fabrication, and Examination (BPV III)

J. Grimm, <i>Chair</i>	M. Lashley
S. Hunter, <i>Secretary</i>	D. W. Mann
W. H. Borter	T. Melfi
G. R. Cannell	I.-K. Nam
S. Cho	J. B. Ossmann
P. J. Coco	J. E. O'Sullivan
R. H. Davis	M. C. Scott
B. D. Frew	W. J. Sperko
D. W. Gandy	J. R. Stinson
S. E. Gingrich	J. F. Strunk
M. Golliet	W. Windes
L. S. Harbison	R. Wright
R. M. Jessee	S. Yee
J. Johnston, Jr.	H. Michael, <i>Delegate</i>
C. C. Kim	R. W. Barnes, <i>Contributing Member</i>
M. Kris	D. B. Denis, <i>Contributing Member</i>

Working Group on HDPE Materials (SG-MFE) (BPV III)

G. Brouette, <i>Chair</i>	D. P. Munson
M. A. Martin, <i>Secretary</i>	T. M. Musto
M. C. Buckley	S. Patterson
M. Golliet	S. Schuessler
J. Johnston, Jr.	R. Stakenborghs
P. Krishnaswamy	M. Troughton
M. Kuntz	J. Wright
B. Lin	B. Hauger, <i>Contributing Member</i>

Joint ACI-ASME Committee on Concrete Components for Nuclear Service (BPV III)

J. A. Munshi, <i>Chair</i>	T. Muraki
J. McLean, <i>Vice Chair</i>	N. Orbovic
J. Cassamassino, <i>Staff Secretary</i>	J. F. Strunk
C. J. Bang	G. Thomas
L. J. Colarusso	S. Wang
A. C. Eberhardt	A. Adediran, <i>Contributing Member</i>
F. Farzam	J. F. Artuso, <i>Contributing Member</i>
P. S. Ghosal	S. Bae, <i>Contributing Member</i>
B. D. Hovis	J.-B. Domage, <i>Contributing Member</i>
T. C. Inman	B. B. Scott, <i>Contributing Member</i>
C. Jones	M. R. Senecal, <i>Contributing Member</i>
O. Jovall	Z. Shang, <i>Contributing Member</i>
T. Kang	M. Sircar, <i>Contributing Member</i>
N.-H. Lee	C. T. Smith, <i>Contributing Member</i>

Working Group on Design (BPV III-2)

N.-H. Lee, <i>Chair</i>	J. A. Munshi
S. Wang, <i>Vice Chair</i>	T. Muraki
M. Allam	N. Orbovic
S. Bae	J. S. Saini
L. J. Colarusso	G. Thomas
A. C. Eberhardt	A. Istar, <i>Contributing Member</i>
F. Farzam	S.-Y. Kim, <i>Contributing Member</i>
P. S. Ghosal	J. Kwon, <i>Contributing Member</i>
B. D. Hovis	B. B. Scott, <i>Contributing Member</i>
T. C. Inman	Z. Shang, <i>Contributing Member</i>
C. Jones	M. Shin, <i>Contributing Member</i>
O. Jovall	M. Sircar, <i>Contributing Member</i>

Working Group on Materials, Fabrication, and Examination (BPV III-2)

C. Jones, <i>Chair</i>	N.-H. Lee
A. Eberhardt, <i>Vice Chair</i>	Z. Shang
M. Allam	J. F. Strunk
C. J. Bang	I. Zivanovic
B. Birch	A. A. Aboelmagd, <i>Contributing Member</i>
J.-B. Domage	J. F. Artuso, <i>Contributing Member</i>
P. S. Ghosal	B. B. Scott, <i>Contributing Member</i>
T. Kang	

Special Working Group on Modernization (BPV III-2)

N. Orbovic, <i>Chair</i>	S. Wang
J. McLean, <i>Vice Chair</i>	I. Zivanovic
A. Adediran	J.-B. Domage, <i>Contributing Member</i>
O. Jovall	F. Lin, <i>Contributing Member</i>
N. Stoeva	M. A. Ugalde, <i>Contributing Member</i>
A. Varma	

Subgroup on Containment Systems for Spent Nuclear Fuel and High-Level Radioactive Material (BPV III)

G. J. Solovey, <i>Chair</i>	D. Siromani
D. J. Ammerman, <i>Vice Chair</i>	D. B. Spencer
S. Klein, <i>Secretary</i>	J. Wellwood
G. Bjorkman	X. J. Zhai
V. Broz	X. Zhang
D. W. Lewis	D. Dunn, <i>Alternate</i>
E. L. Pleins	W. H. Borter, <i>Contributing Member</i>
A. Rigato	N. M. Simpson, <i>Contributing Member</i>
P. Sakalaukus, Jr.	

Subgroup on Fusion Energy Devices (BPV III)

W. K. Sowder, Jr., <i>Chair</i>	S. Lee
D. Andrei, <i>Staff Secretary</i>	G. Li
D. J. Roszman, <i>Secretary</i>	X. Li
M. Bashir	P. Mokaria
J. P. Blanchard	T. R. Muldoon
L. C. Cadwallader	M. Porton
T. P. Davis	F. J. Schaaf, Jr.
B. R. Doshi	P. Smith
L. El-Guebaly	Y. Song
G. Holtmeier	M. Trosen
D. Johnson	C. Waldon
K. A. Kavanagh	I. J. Zatz
K. Kim	R. W. Barnes, <i>Contributing Member</i>
I. Kimihiro	

Working Group on General Requirements (BPV III-4)

D. J. Roszman, <i>Chair</i>	P. Mokaria
M. Ellis	W. K. Sowder, Jr.

Working Group on In-Vessel Components (BPV III-4)

M. Bashir, <i>Chair</i>	M. Kalsey
Y. Carin	S. T. Madabusi
T. P. Davis	

Working Group on Magnets (BPV III-4)

S. Lee, <i>Chair</i>	K. Kim, <i>Vice Chair</i>
----------------------	---------------------------

Working Group on Materials (BPV III-4)

M. Porton, <i>Chair</i>	P. Mummery
T. P. Davis	

Working Group on Vacuum Vessels (BPV III-4)

I. Kimihiro, <i>Chair</i>	D. Johnson
L. C. Cadwallader	Q. Shijun
B. R. Doshi	Y. Song

Subgroup on High Temperature Reactors (BPV III)

S. Sham, <i>Chair</i>	W. Windes
M. Ando	R. Wright
N. Broom	A. Yeshnik
F. W. Brust	G. L. Zeng
P. Carter	A. Tsirigotis, <i>Alternate</i>
M. E. Cohen	D. S. Griffin, <i>Contributing Member</i>
W. J. Geringer	X. Li, <i>Contributing Member</i>
B. F. Hantz	S. Majumdar, <i>Contributing Member</i>
M. H. Jawad	D. L. Marriott, <i>Contributing Member</i>
R. I. Jetter	M. Morishita, <i>Contributing Member</i>
K. Kimura	W. O'Donnell, Sr., <i>Contributing Member</i>
G. H. Koo	L. Shi, <i>Contributing Member</i>
A. Mann	R. W. Swindeman, <i>Contributing Member</i>
M. C. Messner	
X. Wei	

Working Group on Nonmetallic Design and Materials (SG-HTR) (BPV III)

W. Windes, <i>Chair</i>	M. G. Jenkins
W. J. Geringer, <i>Vice Chair</i>	Y. Katoh
A. Appleton	J. Lang
T. D. Burchell	M. N. Mitchell
S.-H. Chi	J. B. Ossmann
V. Chugh	A. Yeshnik
S. T. Gonczy	G. L. Zeng
K. Harris	

Special Working Group on High Temperature Reactor Stakeholders (SG-HTR) (BPV III)

M. E. Cohen, <i>Chair</i>	S. Sham
M. Arcaro	B. Song
R. W. Barnes	X. Wei
N. Broom	A. Yeshnik
V. Chugh	G. L. Zeng
R. A. Fleming	T. Asayama, <i>Contributing Member</i>
K. Harris	X. Li, <i>Contributing Member</i>
R. I. Jetter	M. Morishita, <i>Contributing Member</i>
Y. W. Kim	L. Shi, <i>Contributing Member</i>
G. H. Koo	G. Wu, <i>Contributing Member</i>
K. J. Noel	

Seismic Design Steering Committee (BPV III)

T. M. Adams, <i>Chair</i>	G. H. Koo
F. G. Abatt, <i>Secretary</i>	V. Kostarev
G. A. Antaki	A. Maekawa
C. Basavaraju	K. Matsunaga
A. Berkovsky	R. M. Pace
D. Chowdhury	D. Watkins
R. Döring	

Argentina International Working Group (BPV III)

J. Fernández, <i>Chair</i>	S. A. Echeverría
A. Politi, <i>Vice Chair</i>	E. P. Fresquet
O. Martínez, <i>Staff Secretary</i>	M. M. Gamizo
A. Gomez, <i>Secretary</i>	I. M. Guerreiro
A. Acrogliano	I. A. Knorr
W. Agrelo	M. F. Liendo
G. O. Anteri	D. E. Matthews
M. Anticoli	L. R. Miño
C. A. Araya	J. Monte
J. P. Balbiani	R. L. Morard
A. A. Betervide	A. E. Pastor
D. O. Bordato	E. Pizzichini
G. Bourguigne	J. L. Racamato
M. L. Cappella	H. C. Sanzi
A. Claus	G. J. Scian
R. G. Cocco	G. G. Sebastian
A. Coleff	M. E. Szarko
A. J. Dall'Osto	P. N. Torano
L. M. De Barberis	A. Turrin
D. P. Delfino	O. A. Verastegui
D. N. Dell'Erba	M. D. Vigliano
F. G. Diez	P. Yamamoto
A. Dominguez	M. Zunino

China International Working Group (BPV III)

J. Yan, <i>Chair</i>	C. Peiyin
W. Tang, <i>Vice Chair</i>	Z. Sun
Y. He, <i>Secretary</i>	G. Tang
L. Guo	L. Ting
Y. Jing	Y. Tu
D. Kang	Y. Wang
Y. Li	H. Wu
B. Liang	S. Xue
H. Lin	Z. Yin
S. Liu	D. Yuangang
W. Liu	G. Zhang
J. Ma	W. Zhang
K. Mao	Y. Zhong
D. E. Matthews	Z. Zhong
W. Pei	

Germany International Working Group (BPV III)

J. Wendt, <i>Chair</i>	H.-W. Lange
D. Koelbl, <i>Vice Chair</i>	T. Ludwig
R. Gersinska, <i>Secretary</i>	X. Pitoiset
P. R. Donavin	M. Reichert
R. Döring	G. Roos
C. G. Frantescu	J. Rudolph
A. Huber	L. Sybert
R. E. Hueggenberg	I. Tewes
C. Huttner	R. Tiete
E. Iacopetta	R. Trieglaff
M. H. Koeppen	F. Wille
C. Kuschke	S. Zickler

India International Working Group (BPV III)

R. N. Sen, <i>Chair</i>	A. Johori
S. B. Parkash, <i>Vice Chair</i>	D. Kulkarni
A. D. Bagdare, <i>Secretary</i>	R. Kumar
S. Aithal	D. Narain
S. Benhur	E. L. Pleins
N. M. Borwankar	V. Sehgal
M. Brijlani	S. Singh
H. Dalal	B. K. Sreedhar
S. K. Goyal	

Korea International Working Group (BPV III)

G. H. Koo, <i>Chair</i>	D. Kwon
O.-S. Kim, <i>Secretary</i>	B. Lee
H. Ahn	D. Lee
S. Cho	S. Lee
G.-S. Choi	S.-G. Lee
S. Choi	H. Lim
J. Y. Hong	I.-K. Nam
N.-S. Huh	C.-K. Oh
J.-K. Hwang	C.-Y. Oh
S. S. Hwang	E.-J. Oh
C. Jang	C. Park
I. I. Jeong	H. Park
S. H. Kang	J.-S. Park
J.-I. Kim	Y. S. Pyun
J.-S. Kim	T. Shin
M.-W. Kim	S. Song
S.-S. Kim	W. J. Sperko
Y.-B. Kim	J. S. Yang
Y.-S. Kim	O. Yoo

United Kingdom International Working Group (BPV III)

C. D. Bell, <i>Chair</i>	G. Innes
P. M. James, <i>Vice Chair</i>	S. A. Jones
C. B. Carpenter, <i>Secretary</i>	B. Pellereau
T. Bann	C. R. Schneider
M. J. Chevalier	J. W. Stairmand
M. Consonni	J. Sulley
M. J. Crathorne	J. Talamantes-Silva

Special Working Group on Editing and Review (BPV III)

D. E. Matthews, <i>Chair</i>	S. Hunter
R. P. Deubler	J. C. Minichiello
A. C. Eberhardt	J. F. Strunk
J. V. Gardiner	C. Wilson

Special Working Group on HDPE Stakeholders (BPV III)

M. Brandes, <i>Chair</i>	D. P. Munson
S. Patterson, <i>Secretary</i>	T. M. Musto
S. Choi	J. E. O'Sullivan
C. M. Faigy	V. Rohatgi
M. Golliet	F. J. Schaaf, Jr.
R. M. Jessee	R. Stakenborghs
J. Johnston, Jr.	M. Troughton
M. Kuntz	J. Wright
M. Lashley	C. Lin, <i>Alternate</i>
K. A. Manoly	D. Burwell, <i>Contributing Member</i>

Special Working Group on Honors and Awards (BPV III)

J. C. Minichiello, <i>Chair</i>	R. M. Jessee
A. Appleton	D. E. Matthews
R. W. Barnes	

Special Working Group on Industry Experience for New Plants (BPV III & BPV XI)

J. T. Lindberg, <i>Chair</i>	O.-S. Kim
J. B. Ossmann, <i>Chair</i>	K. Matsunaga
M. C. Buckley, <i>Secretary</i>	D. E. Matthews
A. Cardillo	R. E. McLaughlin
T. L. Chan	D. W. Sandusky
P. J. Hennessey	R. M. Wilson
D. O. Henry	S. M. Yee
J. Honcharik	A. Tsigiriotis, <i>Alternate</i>
C. G. Kim	

Special Working Group on International Meetings and IWG Liaisons (BPV III)

D. E. Matthews, <i>Chair</i>	R. L. Crane
K. Verderber, <i>Staff Secretary</i>	P. R. Donavin
T. M. Adams	E. L. Pleins
R. W. Barnes	W. J. Sperko
T. D. Burchell	

Special Working Group on New Plant Construction Issues (BPV III)

E. L. Pleins, <i>Chair</i>	R. R. Stevenson
M. C. Scott, <i>Secretary</i>	M. L. Wilson
A. Cardillo	H. Xu
P. J. Cocco	J. Yan
J. Honcharik	N. J. Hansing, <i>Alternate</i>
O.-S. Kim	J. C. Minichiello, <i>Contributing Member</i>
M. Kris	
D. W. Sandusky	K. Verderber, <i>Contributing Member</i>

COMMITTEE ON HEATING BOILERS (BPV IV)

J. A. Hall, <i>Chair</i>	M. Mengon
T. L. Bedeaux, <i>Vice Chair</i>	P. A. Molvie
C. R. Ramcharran, <i>Staff Secretary</i>	R. D. Troutt
L. Badziagowski	M. Wadkinson
B. Calderon	R. V. Wielgoszinski
J. P. Chicoine	H. Michael, <i>Delegate</i>
J. M. Downs	D. Picart, <i>Delegate</i>
J. L. Kleiss	D. Nelson, <i>Alternate</i>
J. Klug	S. V. Voorhees, <i>Contributing Member</i>

Subgroup on Care and Operation of Heating Boilers (BPV IV)

R. D. Troutt, <i>Chair</i>	J. A. Hall
C. R. Ramcharran, <i>Staff Secretary</i>	J. L. Kleiss
B. Ahee	P. A. Molvie
T. L. Bedeaux	M. Wadkinson
J. M. Downs	

Subgroup on Cast Boilers (BPV IV)

J. P. Chicoine, <i>Chair</i>	J. A. Hall
J. M. Downs, <i>Vice Chair</i>	J. L. Kleiss
C. R. Ramcharran, <i>Staff Secretary</i>	M. Mengon
T. L. Bedeaux	

Subgroup on Materials (BPV IV)

M. Wadkinson, <i>Chair</i>	L. Badziagowski
J. M. Downs, <i>Vice Chair</i>	T. L. Bedeaux
C. R. Ramcharran, <i>Staff Secretary</i>	J. A. Hall

Subgroup on Water Heaters (BPV IV)

L. Badziagowski, <i>Chair</i>	C. Dinic
J. L. Kleiss, <i>Vice Chair</i>	B. J. Iske
C. R. Ramcharran, <i>Staff Secretary</i>	P. A. Molvie
B. Ahee	T. E. Trant
J. P. Chicoine	R. D. Troutt

Subgroup on Welded Boilers (BPV IV)

T. L. Bedeaux, <i>Chair</i>	M. Mengon
J. L. Kleiss, <i>Vice Chair</i>	P. A. Molvie
C. R. Ramcharran, <i>Staff Secretary</i>	R. D. Troutt
B. Ahee	M. Wadkinson
L. Badziagowski	R. V. Wielgoszinski
B. Calderon	D. Nelson, <i>Alternate</i>
C. Dinic	

COMMITTEE ON NONDESTRUCTIVE EXAMINATION (BPV V)

N. A. Finney, <i>Chair</i>	B. D. Laite
C. May, <i>Vice Chair</i>	L. E. Mullins
C. R. Ramcharran, <i>Staff Secretary</i>	T. L. Plasek
D. Bajula	P. B. Shaw
J. Bennett	C. Vorwald
P. L. Brown	G. M. Gatti, <i>Delegate</i>
M. A. Burns	S. J. Akrin, <i>Contributing Member</i>
N. Carter	J. E. Batey, <i>Contributing Member</i>
T. Clausing	A. S. Birks, <i>Contributing Member</i>
C. Emslander	N. Y. Faransso, <i>Contributing Member</i>
A. F. Garbolevsky	R. W. Kruzic, <i>Contributing Member</i>
J. F. Halley	F. J. Sattler, <i>Contributing Member</i>
P. T. Hayes	H. C. Graber, <i>Honorary Member</i>
G. W. Hembree	O. F. Hedden, <i>Honorary Member</i>
F. B. Kovacs	J. R. MacKay, <i>Honorary Member</i>
K. Krueger	T. G. McCarty, <i>Honorary Member</i>

Executive Committee (BPV V)

C. May, <i>Chair</i>	J. F. Halley
N. A. Finney, <i>Vice Chair</i>	P. T. Hayes
C. R. Ramcharran, <i>Staff Secretary</i>	G. W. Hembree
N. Carter	F. B. Kovacs
C. Emslander	C. Vorwald
V. F. Godinez-Azcuaga	

Subgroup on General Requirements/Personnel Qualifications and Inquiries (BPV V)

C. Emslander, <i>Chair</i>	F. B. Kovacs
D. I. Morris, <i>Vice Chair</i>	K. Krueger
J. Bennett	C. May
N. Carter	C. Vorwald
T. Clausing	S. J. Akrin, <i>Contributing Member</i>
N. A. Finney	J. E. Batey, <i>Contributing Member</i>
J. F. Halley	N. Y. Faransso, <i>Contributing Member</i>
G. W. Hembree	J. P. Swezy, Jr., <i>Contributing Member</i>

Subgroup on Surface Examination Methods (BPV V)

N. Carter, <i>Chair</i>	L. E. Mullins
B. D. Laite, <i>Vice Chair</i>	P. B. Shaw
P. L. Brown	C. Vorwald
T. Clausing	C. Wassink
C. Emslander	D. M. Woodward
N. Farenbaugh	G. M. Gatti, <i>Delegate</i>
N. A. Finney	S. J. Akrin, <i>Contributing Member</i>
J. F. Halley	J. E. Batey, <i>Contributing Member</i>
K. Hayes	N. Y. Faransso, <i>Contributing Member</i>
G. W. Hembree	R. W. Kruzic, <i>Contributing Member</i>
C. May	F. J. Sattler, <i>Contributing Member</i>

Subgroup on Volumetric Methods (BPV V)

C. May, *Chair*
 J. F. Halley, *Vice Chair*
 D. Adkins
 P. L. Brown
 N. A. Finney
 A. F. Garbolevsky
 R. W. Hardy
 P. T. Hayes
 G. W. Hembree
 F. B. Kovacs
 K. Krueger

L. E. Mullins
 E. Peloquin
 T. L. Plasek
 C. Vorwald
 G. M. Gatti, *Delegate*
 S. J. Akryn, *Contributing Member*
 J. E. Batey, *Contributing Member*
 N. Y. Faransso, *Contributing Member*
 R. W. Kruzic, *Contributing Member*
 F. J. Sattler, *Contributing Member*

Special Working Group on Advanced Ultrasonic Testing Techniques (BPV V)

L. E. Mullins, *Chair*
 K. Krueger, *Vice Chair*
 D. Adkins
 D. Bajula
 N. A. Finney
 J. L. Garner
 J. F. Halley

P. T. Hayes
 M. Lozev
 E. Peloquin
 M. Sens
 D. Tompkins
 C. Wassink

Working Group on Full Matrix Capture (FMC) (BPV V)

P. T. Hayes, *Chair*
 E. Peloquin, *Vice Chair*
 D. Adkins
 D. Bajula
 D. Bellistri
 J. Catty
 N. A. Finney
 J. L. Garner
 V. F. Godinez-Azcuaga
 R. T. Grotenhuis
 J. F. Halley

K. Hayes
 G. W. Hembree
 K. Krueger
 M. Lozev
 L. E. Mullins
 D. Richard
 M. Sens
 D. Tompkins
 O. Volf
 C. Wassink

Working Group on Acoustic Emissions (SG-VM) (BPV V)

V. F. Godinez-Azcuaga, *Chair*
 S. R. Doctor, *Vice Chair*
 J. Catty
 N. F. Douglas, Jr.

R. K. Miller
 L. Zhang
 J. E. Batey, *Contributing Member*
 N. Y. Faransso, *Contributing Member*

Working Group on Computed Tomography (BPV V)

C. May, *Chair*
 T. L. Clifford
 R. W. Hardy
 G. W. Hembree
 F. B. Kovacs

R. J. Mills
 T. L. Plasek
 C. Vorwald
 B. White
 L. E. Mullins, *Contributing Member*

Working Group on Radiography (SG-VM) (BPV V)

C. Vorwald, *Chair*
 D. M. Woodward, *Vice Chair*
 J. Anderson
 P. L. Brown
 C. Emslander
 A. F. Garbolevsky
 R. W. Hardy
 G. W. Hembree
 F. B. Kovacs
 B. D. Laite

C. May
 R. J. Mills
 T. L. Plasek
 T. Vidimos
 B. White
 S. J. Akryn, *Contributing Member*
 J. E. Batey, *Contributing Member*
 N. Y. Faransso, *Contributing Member*
 R. W. Kruzic, *Contributing Member*

Working Group on Ultrasonics (SG-VM) (BPV V)

J. F. Halley, *Chair*
 K. Krueger, *Vice Chair*
 D. Adkins
 D. Bajula
 C. Brown
 C. Emslander
 N. A. Finney
 P. T. Hayes
 G. W. Hembree
 B. D. Laite
 C. May
 L. E. Mullins
 E. Peloquin
 M. J. Quarry

D. Tompkins
 D. Van Allen
 J. Vinyard
 C. Vorwald
 C. Wassink
 D. Alleyne, *Contributing Member*
 J. E. Batey, *Contributing Member*
 N. Y. Faransso, *Contributing Member*
 R. W. Kruzic, *Contributing Member*
 G. M. Light, *Contributing Member*
 P. Mudge, *Contributing Member*
 F. J. Sattler, *Contributing Member*
 J. Vanvelsor, *Contributing Member*

Italy International Working Group (BPV V)

P. L. Dinelli, *Chair*
 D. D. Raimander, *Secretary*
 M. Agostini
 T. Aldo
 F. Bresciani
 G. Campos
 N. Caputo
 M. Colombo
 F. Ferrarese
 E. Ferrari

M. A. Grimoldi
 G. Luoni
 O. Oldani
 U. Papponetti
 P. Pedersoli
 A. Veroni
 M. Zambon
 V. Calo, *Contributing Member*
 G. Gobbi, *Contributing Member*
 G. Pontiggia, *Contributing Member*

COMMITTEE ON PRESSURE VESSELS (BPV VIII)

S. C. Roberts, *Chair*
 M. D. Lower, *Vice Chair*
 J. Oh, *Staff Secretary*
 S. J. Rossi, *Staff Secretary*
 G. Aurioles, Sr.
 S. R. Babka
 R. J. Basile
 P. Chavdarov
 D. B. DeMichael
 J. F. Grubb
 B. F. Hantz
 M. Kowalczyk
 D. L. Kurle
 R. Mahadeen
 S. A. Marks
 P. Matkovic
 R. W. Mikitka
 B. R. Morelock
 T. P. Pastor
 D. T. Peters
 M. J. Pischke
 M. D. Rana
 G. B. Rawls, Jr.
 F. L. Richter
 C. D. Rodery

J. C. Sowinski
 D. Srnec
 D. B. Stewart
 P. L. Sturgill
 K. Subramanian
 D. A. Swanson
 J. P. Swezy, Jr.
 S. Terada
 E. Upitis
 A. Viet
 K. Xu
 P. A. McGowan, *Delegate*
 H. Michael, *Delegate*
 K. Oyamada, *Delegate*
 M. E. Papponetti, *Delegate*
 X. Tang, *Delegate*
 A. Chaudouet, *Contributing Member*
 J. P. Glaspie, *Contributing Member*
 W. S. Jacobs, *Contributing Member*
 K. T. Lau, *Contributing Member*
 U. R. Miller, *Contributing Member*
 K. Mokhtarian, *Contributing Member*
 G. G. Karcher, *Honorary Member*
 K. K. Tam, *Honorary Member*

Executive Committee (BPV VIII)

M. D. Lower, *Chair*
 S. J. Rossi, *Staff Secretary*
 G. Aurioles, Sr.
 M. Kowalczyk
 S. A. Marks
 P. Matkovic

F. L. Richter
 S. C. Roberts
 J. C. Sowinski
 K. Subramanian
 A. Viet
 K. Xu

Subgroup on Design (BPV VIII)

J. C. Sowinski, *Chair*
 C. S. Hinson, *Vice Chair*
 G. Auriolos, Sr.
 S. R. Babka
 O. A. Barsky
 R. J. Basile
 D. Chandiramani
 M. Faulkner
 B. F. Hantz
 C. E. Hinnant
 M. H. Jawad
 S. Krishnamurthy
 D. L. Kurle
 K. Kescu
 M. D. Lower
 R. W. Mikitka
 B. Millet
 M. D. Rana
 G. B. Rawls, Jr.

S. C. Roberts
 C. D. Rodery
 T. G. Seipp
 D. Srnic
 D. A. Swanson
 S. Terada
 J. Vattappilly
 K. Xu
 K. Oyamada, *Delegate*
 M. E. Papponetti, *Delegate*
 W. S. Jacobs, *Contributing Member*
 P. K. Lam, *Contributing Member*
 K. Mokhtarian, *Contributing Member*
 T. P. Pastor, *Contributing Member*
 S. C. Shah, *Contributing Member*
 K. K. Tam, *Contributing Member*
 E. Upitis, *Contributing Member*
 Z. Wang, *Contributing Member*

Working Group on Design-By-Analysis (BPV VIII)

B. F. Hantz, *Chair*
 T. W. Norton, *Secretary*
 D. A. Arnett
 J. Bedoya
 S. Guzey
 C. F. Heberling II
 C. E. Hinnant
 M. H. Jawad
 S. Kataoka
 S. Kilambi
 K. D. Kirkpatrick

S. Krishnamurthy
 A. Mann
 C. Nadarajah
 P. Prueter
 T. G. Seipp
 M. A. Shah
 S. Terada
 R. G. Brown, *Contributing Member*
 D. Dewees, *Contributing Member*
 K. Saboda, *Contributing Member*

Working Group on Elevated Temperature Design (BPV I and VIII)

A. Mann, *Chair*
 C. Nadarajah, *Secretary*
 D. Anderson
 D. Dewees
 B. F. Hantz
 M. H. Jawad
 R. I. Jetter
 S. Krishnamurthy
 T. Le

M. C. Messner
 M. N. Mitchell
 P. Prueter
 M. J. Swindeman
 J. P. Glaspie, *Contributing Member*
 D. L. Marriott, *Contributing Member*
 N. McMurray, *Contributing Member*
 B. J. Mollitor, *Contributing Member*

Subgroup on Fabrication and Examination (BPV VIII)

S. A. Marks, *Chair*
 D. I. Morris, *Vice Chair*
 T. Halligan, *Secretary*
 N. Carter
 J. Lu
 B. R. Morelock
 O. Mulet
 M. J. Pischke
 M. J. Rice
 J. Roberts
 C. D. Rodery
 B. F. Shelley
 D. Smith

P. L. Sturgill
 J. P. Swezy, Jr.
 E. Upitis
 C. Violand
 E. A. Whittle
 K. Oyamada, *Delegate*
 W. J. Bees, *Contributing Member*
 L. F. Campbell, *Contributing Member*
 J. Lee, *Contributing Member*
 J. Si, *Contributing Member*
 R. Uebel, *Contributing Member*
 X. Xue, *Contributing Member*
 B. Yang, *Contributing Member*

Subgroup on General Requirements (BPV VIII)

F. L. Richter, *Chair*
 M. Faulkner, *Vice Chair*
 J. Hoskinson, *Secretary*
 N. Barkley
 R. J. Basile
 T. P. Beirne
 D. T. Davis
 D. B. DeMichael
 M. D. Lower
 T. P. Pastor
 D. K. Peetz

G. B. Rawls, Jr.
 S. C. Roberts
 J. C. Sowinski
 P. Speranza
 D. Srnic
 D. B. Stewart
 D. A. Swanson
 R. Uebel
 J. P. Glaspie, *Contributing Member*
 Z. Wang, *Contributing Member*
 Y. Yang, *Contributing Member*

Task Group on Fired Heater Pressure Vessels (BPV VIII)

J. Hoskinson, *Chair*
 J. Bradley
 W. Kim
 S. Kirk
 D. Nelson
 T. P. Pastor

R. Robles
 J. Rust
 P. Shanks
 E. Smith
 D. Srnic
 J. P. Swezy, Jr.

Task Group on Subsea Applications (BPV VIII)

M. Sarzynski, *Chair*
 A. J. Grohmann, *Vice Chair*
 L. P. Antalffy
 R. C. Biel
 J. Ellens
 J. Hademenos
 J. Kaculi
 K. Karpanan
 F. Kirkemo
 C. Lan

P. Lutkiewicz
 N. McKie
 S. K. Parimi
 R. H. Patil
 J. R. Sims
 M. P. Vaclavik
 R. Cordes, *Contributing Member*
 S. Krishna, *Contributing Member*
 D. T. Peters, *Contributing Member*

Task Group on UG-20(f) (BPV VIII)

S. Krishnamurthy, *Chair*
 T. L. Anderson
 K. E. Bagnoli
 R. P. Deubler
 B. F. Hantz

B. R. Macejko
 J. Penso
 M. Prager
 M. D. Rana

Subgroup on Heat Transfer Equipment (BPV VIII)

P. Matkovics, *Chair*
 M. D. Clark, *Vice Chair*
 L. Bower, *Secretary*
 G. Auriolos, Sr.
 S. R. Babka
 J. H. Barbee
 O. A. Barsky
 T. Bunyarattaphantu
 A. Chaudouet
 D. L. Kurle
 R. Mahadeen

S. Mayeux
 S. Neilsen
 E. Smith
 A. M. Voytko
 R. P. Wiberg
 I. G. Campbell, *Contributing Member*
 G. G. Karcher, *Contributing Member*
 J. Pasek, *Contributing Member*
 D. Srnic, *Contributing Member*
 Z. Tong, *Contributing Member*

Working Group on Plate Heat Exchangers (BPV VIII)

P. Matkovics, *Chair*
 S. R. Babka
 J. F. Grubb
 V. Gudge
 R. Mahadeen
 S. A. Marks

D. I. Morris
 M. J. Fischke
 E. Smith
 D. Srnic
 S. Sullivan

Subgroup on High Pressure Vessels (BPV VIII)

K. Subramanian, *Chair*
M. Sarzynski, *Vice Chair*
A. P. Maslowski, *Staff Secretary*
L. P. Antalffy
R. C. Biel
P. N. Chaku
L. Fridlund
R. T. Hallman
K. Karpanan
J. Keltjens
A. K. Khare
G. M. Mital
G. T. Nelson
M. Parr
D. T. Peters
E. A. Rodriguez
E. D. Roll
J. R. Sims
E. Smith
F. W. Tatar
S. Terada

C. Tipple
R. Wink
Y. Xu
A. M. Clayton, *Contributing Member*
R. Cordes, *Contributing Member*
R. D. Dixon, *Contributing Member*
Q. Dong, *Contributing Member*
T. A. Duffey, *Contributing Member*
D. Fuenmayor, *Contributing Member*
R. M. Hoshman, *Contributing Member*
Y. Huang, *Contributing Member*
F. Kirkemo, *Contributing Member*
R. A. Leishear, *Contributing Member*
C. Romero, *Contributing Member*
K.-J. Young, *Contributing Member*
D. J. Burns, *Honorary Member*
D. M. Fryer, *Honorary Member*
G. J. Mraz, *Honorary Member*
E. H. Perez, *Honorary Member*

Subgroup on Materials (BPV VIII)

M. Kowalczyk, *Chair*
J. Cameron, *Vice Chair*
S. Kilambi, *Secretary*
P. Chavdarov
J. F. Grubb
D. Maitra
D. W. Raho
J. Robertson
R. C. Sutherland
E. Uptis
K. Xu

S. Yem
A. Di Rienzo, *Contributing Member*
J. D. Fritz, *Contributing Member*
M. Katcher, *Contributing Member*
W. M. Lundy, *Contributing Member*
J. A. McMaster, *Contributing Member*
J. Penso, *Contributing Member*
B. Pletcher, *Contributing Member*
P. G. Wittenbach, *Contributing Member*
X. Wu, *Contributing Member*

Subgroup on Toughness (BPV VIII)

K. Xu, *Chair*
T. Halligan, *Vice Chair*
N. Carter
C. S. Hinson
W. S. Jacobs
S. Kilambi
D. L. Kurlle
M. D. Rana
F. L. Richter
K. Subramanian

D. A. Swanson
J. P. Swezy, Jr.
S. Terada
E. Uptis
J. Vattappilly
K. Oyamada, *Delegate*
S. Krishnamurthy, *Contributing Member*
K. Mokhtarian, *Contributing Member*

Subgroup on Graphite Pressure Equipment (BPV VIII)

A. Viet, *Chair*
C. W. Cary, *Vice Chair*
G. C. Becherer
F. L. Brown
R. J. Bulgin

J. D. Clements
H. Lee, Jr.
T. Rudy
A. A. Stupica

Argentina International Working Group (BPV VIII)

A. Dominguez, *Chair*
F. P. Larrosa, *Secretary*
M. M. Acosta
R. A. Barey
C. Alderetes
F. A. Andres
L. F. Boccanera
O. S. Bretones
A. Burgueno
G. Casanas
D. H. Da Rold
J. I. Duo
M. Favareto

M. D. Kuhn
L. M. Leccese
C. Meinl
M. A. Mendez
J. J. Monaco
M. A. A. Pipponzi
D. Rizzo
R. Robles
J. C. Rubeo
S. Schamun
G. Telleria
M. M. C. Tocco

China International Working Group (BPV VIII)

X. Chen, *Chair*
B. Shou, *Vice Chair*
Z. Fan, *Secretary*
Y. Chen
Z. Chen
J. Cui
R. Duan
W. Guo
B. Han
J. Hu
Q. Hu
H. Hui
D. Luo
Y. Luo

C. Miao
X. Qian
L. Sun
B. Wang
C. Wu
F. Xu
F.-Z. Xuan
Y. Yang
K. Zhang
Yanfeng Zhang
Yijun Zhang
S. Zhao
J. Zheng
G. Zhu

Germany International Working Group (BPV VIII)

P. Chavdarov, *Chair*
M. Sykora, *Vice Chair*
B. Daume
A. Emrich
J. Fleischfresser
R. Helmholdt
R. Kauer
D. Koelbl
S. Krebs

T. Ludwig
R. A. Meyers
H. Michael
S. Reich
A. Spangenberg
G. Naumann, *Contributing Member*
P. Paluszkiwicz, *Contributing Member*
R. Uebel, *Contributing Member*

India International Working Group (BPV VIII)

D. Chandiramani, *Chair*
D. Kulkarni, *Vice Chair*
A. D. Dalal, *Secretary*
P. Arulkumar
B. Basu
P. Gandhi
S. K. Goyal
V. Jayabalan
A. Kakumanu
V. V. P. Kumar

T. Mukherjee
P. C. Pathak
S. B. Patil
D. Prabhu
A. Sadasivam
M. P. Shah
R. Tiru
V. T. Valavan
M. Sharma, *Contributing Member*

Italy International Working Group (BPV VIII)

A. Teli, <i>Chair</i>	M. Guglielmetti
D. D. Raimander, <i>Secretary</i>	A. F. Magri
B. G. Alborali	P. Mantovani
P. Aliprandi	M. Millefanti
A. Avogadri	L. Moracchioli
A. Camanni	P. Pacor
M. Colombo	G. Pontiggia
P. Conti	S. Sarti
D. Cortassa	A. Veroni
P. L. Dinelli	G. Gobbi, <i>Contributing Member</i>
F. Finco	

Special Working Group on Bolted Flanged Joints (BPV VIII)

R. W. Mikitka, <i>Chair</i>	W. McDaniel
G. Auriolles, Sr.	M. Osterfoss
D. Bankston, Jr.	J. R. Payne
W. Brown	G. B. Rawls, Jr.
H. Chen	R. Wacker
A. Mann	

Subgroup on Interpretations (BPV VIII)

G. Auriolles, Sr., <i>Chair</i>	C. D. Rodery
J. Oh, <i>Staff Secretary</i>	T. G. Seipp
S. R. Babka	J. C. Sowinski
J. Cameron	D. B. Stewart
N. Carter	D. A. Swanson
C. W. Cary	J. P. Swezy, Jr.
B. F. Hantz	J. Vattappilly
M. Kowalczyk	A. Viet
D. L. Kurle	K. Xu
M. D. Lower	R. J. Basile, <i>Contributing Member</i>
A. Mann	D. B. DeMichael, <i>Contributing Member</i>
S. A. Marks	R. D. Dixon, <i>Contributing Member</i>
P. Matkovic	S. Kilambi, <i>Contributing Member</i>
G. M. Mital	R. Mahadeen, <i>Contributing Member</i>
D. I. Morris	T. P. Pastor, <i>Contributing Member</i>
D. T. Peters	P. L. Sturgill, <i>Contributing Member</i>
F. L. Richter	
S. C. Roberts	

COMMITTEE ON WELDING, BRAZING, AND FUSING (BPV IX)

D. A. Bowers, <i>Chair</i>	M. B. Sims
M. J. Pischke, <i>Vice Chair</i>	W. J. Sperko
E. Lawson, <i>Staff Secretary</i>	P. L. Sturgill
M. Bernasek	J. P. Swezy, Jr.
M. A. Boring	E. W. Woelfel
J. G. Feldstein	D. Pojatar, <i>Delegate</i>
P. D. Flenner	A. Roza, <i>Delegate</i>
S. E. Gingrich	M. Consonni, <i>Contributing Member</i>
K. L. Hayes	S. A. Jones, <i>Contributing Member</i>
R. M. Jessee	S. Raghunathan, <i>Contributing Member</i>
J. S. Lee	
W. M. Lundy	M. J. Stanko, <i>Contributing Member</i>
S. A. Marks	P. L. Van Fosson, <i>Contributing Member</i>
T. Melfi	
W. F. Newell, Jr.	R. K. Brown, Jr., <i>Honorary Member</i>
D. K. Peetz	M. L. Carpenter, <i>Honorary Member</i>
E. G. Reichelt	B. R. Newmark, <i>Honorary Member</i>
M. J. Rice	S. D. Reynolds, Jr., <i>Honorary Member</i>

Subgroup on Brazing (BPV IX)

S. A. Marks, <i>Chair</i>	A. R. Nywening
E. W. Beckman	M. J. Pischke
A. F. Garbolevsky	J. P. Swezy, Jr.
N. Mohr	

Subgroup on General Requirements (BPV IX)

P. L. Sturgill, <i>Chair</i>	D. K. Peetz
N. Carter, <i>Vice Chair</i>	H. B. Porter
S. A. Marks, <i>Secretary</i>	J. P. Swezy, Jr.
J. P. Bell	E. W. Woelfel
D. A. Bowers	E. Molina, <i>Delegate</i>
P. Gilston	E. W. Beckman, <i>Contributing Member</i>
M. Heinrichs	B. R. Newmark, <i>Honorary Member</i>
A. Howard	
R. M. Jessee	

Subgroup on Materials (BPV IX)

M. Bernasek, <i>Chair</i>	M. J. Pischke
T. Anderson	A. Roza
E. Cutlip	C. E. Sainz
M. Denault	P. L. Sturgill
S. E. Gingrich	C. Zanfir
L. S. Harbison	V. G. V. Giunto, <i>Delegate</i>
M. James	D. J. Kotecki, <i>Contributing Member</i>
R. M. Jessee	B. Krueger, <i>Contributing Member</i>
T. Melfi	W. J. Sperko, <i>Contributing Member</i>
S. D. Nelson	M. J. Stanko, <i>Contributing Member</i>

Subgroup on Plastic Fusing (BPV IX)

E. W. Woelfel, <i>Chair</i>	E. G. Reichelt
D. Burwell	M. J. Rice
K. L. Hayes	S. Schuessler
R. M. Jessee	M. Troughton
J. Johnston, Jr.	C. Violand
J. E. O'Sullivan	J. Wright

Subgroup on Strength of Weldments (BPV II and IX)

G. W. Galanes, <i>Chair</i>	J. Penso
K. L. Hayes, <i>Vice Chair</i>	D. W. Rahoi
S. H. Bowes, <i>Secretary</i>	B. Roberts
K. K. Coleman	W. J. Sperko
M. Denault	J. P. Swezy, Jr.
J. R. Foulds	M. Ueyama
D. W. Gandy	A. A. Amiri, <i>Contributing Member</i>
M. Ghahremani	P. D. Flenner, <i>Contributing Member</i>
J. Henry	J. J. Sanchez-Hanton, <i>Contributing Member</i>
W. F. Newell, Jr.	

Subgroup on Welding Qualifications (BPV IX)

M. J. Rice, <i>Chair</i>	B. R. Newton
J. S. Lee, <i>Vice Chair</i>	E. G. Reichelt
K. L. Hayes, <i>Secretary</i>	M. B. Sims
M. Bernasek	W. J. Sperko
M. A. Boring	S. A. Sprague
D. A. Bowers	P. L. Sturgill
R. Campbell	J. P. Swezy, Jr.
R. B. Corbit	C. Violand
P. D. Flenner	A. D. Wilson
L. S. Harbison	D. Chandiramani, <i>Contributing Member</i>
M. Heinrichs	M. Consonni, <i>Contributing Member</i>
W. M. Lundy	M. Dehghan, <i>Contributing Member</i>
D. W. Mann	T. C. Wiesner, <i>Contributing Member</i>
T. Melfi	
W. F. Newell, Jr.	

Argentina International Working Group (BPV IX)

A. Burgueno, <i>Chair</i>	J. A. Herrera
E. Lawson, <i>Staff Secretary</i>	M. D. Kuhn
B. Bardott	M. A. Mendez
L. F. Boccanera	A. E. Pastor
M. Favareto	G. Telleria
C. A. Garibotti	M. M. C. Tocco

Germany International Working Group (BPV IX)

P. Chavdarov, <i>Chair</i>	S. Krebs
A. Spangenberg, <i>Vice Chair</i>	T. Ludwig
E. Lawson, <i>Staff Secretary</i>	G. Naumann
P. Thiebo, <i>Secretary</i>	A. Roza
J. Daldrup	K.-G. Toelle
B. Daume	S. Wegener
J. Fleischfresser	F. Wodke
E. Floer	R. Helmholdt

Italy International Working Group (BPV IX)

D. D. Raimander, <i>Chair</i>	L. Moracchioli
M. Bernasek	P. Pacor
A. Camanni	G. Pontiggia
P. L. Dinelli	P. Siboni
F. Ferrarese	A. Volpi
M. Mandina	V. Calo, <i>Contributing Member</i>
A. S. Monastra	G. Gobbi, <i>Contributing Member</i>

Spain International Working Group (BPV IX)

F. J. Q. Pandelo, <i>Chair</i>	F. Manas
F. L. Villabrille, <i>Vice Chair</i>	B. B. Miguel
E. Lawson, <i>Staff Secretary</i>	A. D. G. Munoz
F. R. Hermida, <i>Secretary</i>	A. B. Pascual
C. A. Celimendiz	S. Sevil
M. A. F. Garcia	G. Gobbi, <i>Contributing Member</i>
R. G. Garcia	

COMMITTEE ON FIBER-REINFORCED PLASTIC PRESSURE VESSELS (BPV X)

B. Linnemann, <i>Chair</i>	L. E. Hunt
B. F. Shelley, <i>Vice Chair</i>	D. L. Keeler
P. D. Stumpf, <i>Staff Secretary</i>	D. H. McCauley
A. L. Beckwith	N. L. Newhouse
F. L. Brown	G. Ramirez
J. L. Bustillos	J. R. Richter
B. R. Colley	S. L. Wagner
T. W. Cowley	D. O. Yancey, Jr.
I. L. Dinovo	P. H. Ziehl
D. Eisberg	D. H. Hodgkinson, <i>Contributing Member</i>
M. R. Gorman	
B. Hebb	

COMMITTEE ON NUCLEAR INSERVICE INSPECTION (BPV XI)

R. W. Swayne, <i>Chair</i>	N. A. Palm
S. D. Kulat, <i>Vice Chair</i>	G. C. Park
D. W. Lamond, <i>Vice Chair</i>	A. T. Roberts III
D. Miro-Quesada, <i>Staff Secretary</i>	D. A. Scarth
J. F. Ball	F. J. Schaaf, Jr.
W. H. Bamford	S. Takaya
J. M. Boughman	D. Vetter
C. Brown	T. V. Vo
S. B. Brown	D. E. Waskey
T. L. Chan	J. G. Weicks
R. C. Cipolla	M. Weis
D. R. Cordes	Y.-K. Chung, <i>Delegate</i>
H. Do	C. Ye, <i>Delegate</i>
E. V. Farrell, Jr.	M. L. Benson, <i>Alternate</i>
M. J. Ferlisi	J. K. Loy, <i>Alternate</i>
P. D. Fisher	R. O. McGill, <i>Alternate</i>
T. J. Griesbach	D. J. Shim, <i>Alternate</i>
J. Hakii	A. Udyawar, <i>Alternate</i>
M. L. Hall	E. B. Gerlach, <i>Contributing Member</i>
D. O. Henry	B. R. Newton, <i>Contributing Member</i>
W. C. Holston	C. D. Cowfer, <i>Honorary Member</i>
J. T. Lindberg	D. D. Davis, <i>Honorary Member</i>
G. A. Lofthus	R. E. Gimple, <i>Honorary Member</i>
H. Malikowski	F. E. Gregor, <i>Honorary Member</i>
S. L. McCracken	O. F. Hedden, <i>Honorary Member</i>
S. A. Norman	R. D. Kerr, <i>Honorary Member</i>
C. A. Nove	P. C. Riccardella, <i>Honorary Member</i>
T. Nuoffer	R. A. West, <i>Honorary Member</i>
J. Nygaard	C. J. Wirtz, <i>Honorary Member</i>
J. E. O'Sullivan	R. A. Yonekawa, <i>Honorary Member</i>

Executive Committee (BPV XI)

S. D. Kulat, <i>Chair</i>	S. L. McCracken
R. W. Swayne, <i>Vice Chair</i>	C. A. Nove
D. Miro-Quesada, <i>Staff Secretary</i>	T. Nuoffer
W. H. Bamford	N. A. Palm
M. J. Ferlisi	G. C. Park
D. W. Lamond	A. T. Roberts III
J. T. Lindberg	M. L. Benson, <i>Alternate</i>

Argentina International Working Group (BPV XI)

F. M. Schroeter, <i>Chair</i>	R. J. Lopez
O. Martinez, <i>Staff Secretary</i>	M. Magliocchi
D. A. Cipolla	L. R. Miño
A. Claus	J. Monte
D. Costa	M. D. Pereda
D. P. Delfino	A. Politi
D. N. Dell'Erba	C. G. Real
A. Dominguez	F. J. Schaaf, Jr.
S. A. Echeverria	G. J. Scian
E. P. Fresquet	M. J. Solari
M. M. Gamizo	P. N. Torano
I. M. Guerreiro	P. Yamamoto
F. Llorente	

China International Working Group (BPV XI)

J. H. Liu, <i>Chair</i>	S. Shuo
Y. Nie, <i>Vice Chair</i>	Y. Sixin
C. Ye, <i>Vice Chair</i>	Y. X. Sun
M. W. Zhou, <i>Secretary</i>	G. X. Tang
J. F. Cai	Q. Wang
H. Chen	Q. W. Wang
H. D. Chen	Z. S. Wang
Y. Cheng	L. Xing
Y. B. Guo	F. Xu
Y. Hongqi	S. X. Xu
D. R. Horn	Q. Yin
Y. Hou	K. Zhang
S. X. Lin	Y. Zhe
W. N. Pei	Z. M. Zhong
L. Shiwei	

German International Working Group (BPV XI)

R. Döring, <i>Chair</i>	N. Legl
R. Trieglaff, <i>Vice Chair</i>	T. Ludwig
R. Piel, <i>Secretary</i>	X. Pitoiset
A. Casse	M. Reichert
S. Dugan	L. Sybertz
C. G. Frantescu	I. Tewes
M. Hagenbruch	R. Tiete
E. Iacopetta	J. Wendt
S. D. Kulat	S. Zickler
H.-W. Lange	

India International Working Group (BPV XI)

S. B. Parkash, <i>Chair</i>	N. Palm
D. Narain, <i>Vice Chair</i>	D. Rawal
K. K. Rai, <i>Secretary</i>	R. Sahai
Z. M. Mansuri	R. K. Sharma
M. R. Nadgouda	

Special Working Group on Editing and Review (BPV XI)

R. W. Swayne, <i>Chair</i>	K. R. Rao
M. Orihuela	

Task Group on Inspectability (BPV XI)

J. T. Lindberg, <i>Chair</i>	G. A. Lofthus
E. Henry, <i>Secretary</i>	S. Matsumoto
A. Cardillo	D. E. Matthews
D. R. Cordes	P. J. O'Regan
M. J. Ferlisi	J. B. Ossmann
P. Gionta	S. A. Sabo
D. O. Henry	P. Sullivan
J. Honcharik	C. Thomas
R. Klein	J. Tucker
C. Latiolais	

Task Group on ISI of Spent Nuclear Fuel Storage and Transportation Containment Systems (BPV XI)

K. Hunter, <i>Chair</i>	M. Liu
M. Orihuela, <i>Secretary</i>	K. Mauskar
D. J. Ammerman	R. M. Meyer
W. H. Borter	B. L. Montgomery
J. Broussard	R. M. Pace
S. Brown	E. L. Pleins
C. R. Bryan	M. A. Richter
T. Carraher	B. Sarno
S. Corcoran	R. Sindelar
D. Dunn	M. Staley
N. Fales	J. Wellwood
R. C. Folley	X. J. Zhai
G. Grant	P.-S. Lam, <i>Alternate</i>
B. Gutherman	G. White, <i>Alternate</i>
M. W. Joseph	J. Wise, <i>Alternate</i>
M. Keene	H. Smith, <i>Contributing Member</i>

Subgroup on Evaluation Standards (SG-ES) (BPV XI)

W. H. Bamford, <i>Chair</i>	R. O. McGill
N. A. Palm, <i>Secretary</i>	H. S. Mehta
M. Brumovsky	K. Miyazaki
H. D. Chung	R. M. Pace
R. C. Cipolla	J. C. Poehler
C. M. Faigy	S. Ranganath
M. M. Farooq	D. A. Scarth
B. R. Ganta	D. J. Shim
T. J. Griesbach	G. L. Stevens
K. Hasegawa	A. Udyawar
K. Hojo	T. V. Vo
D. N. Hopkins	G. M. Wilkowski
D. R. Lee	S. X. Xu
Y. S. Li	M. L. Benson, <i>Alternate</i>

Task Group on Evaluation of Beyond Design Basis Events (SG-ES) (BPV XI)

R. M. Pace, <i>Chair</i>	M. Hayashi
S. X. Xu, <i>Secretary</i>	K. Hojo
F. G. Abatt	S. A. Kleinsmith
G. A. Antaki	H. S. Mehta
P. R. Donavin	T. V. Vo
R. G. Gilada	G. M. Wilkowski
T. J. Griesbach	T. Weaver, <i>Contributing Member</i>

Working Group on Flaw Evaluation (SG-ES) (BPV XI)

R. C. Cipolla, <i>Chair</i>	C. Liu
S. X. Xu, <i>Secretary</i>	M. Liu
W. H. Bamford	H. S. Mehta
M. L. Benson	G. A. A. Miessi
M. Brumovsky	K. Miyazaki
H. D. Chung	S. Noronha
M. A. Erickson	R. K. Qashu
C. M. Faidy	S. Ranganath
M. M. Farooq	P. J. Rush
B. R. Ganta	D. A. Scarth
R. G. Gilada	W. L. Server
F. D. Hayes	D. J. Shim
P. H. Hoang	S. Smith
K. Hojo	M. Uddin
D. N. Hopkins	A. Udyawar
S. Kalyanam	T. V. Vo
Y. Kim	K. Wang
V. Lacroix	B. Wasiluk
D. R. Lee	G. M. Wilkowski
Y. S. Li	

Working Group on Pipe Flaw Evaluation (SG-ES) (BPV XI)

D. A. Scarth, <i>Chair</i>	S. Kalyanam
G. M. Wilkowski, <i>Secretary</i>	K. Kashima
K. Azuma	V. Lacroix
M. L. Benson	Y. S. Li
M. Brumovsky	R. O. McGill
F. W. Brust	H. S. Mehta
H. D. Chung	G. A. A. Miessi
R. C. Cipolla	K. Miyazaki
N. G. Cofie	S. H. Pellet
C. M. Faidy	P. J. Rush
M. M. Farooq	C. J. Sallaberry
B. R. Ganta	W. L. Server
S. R. Gosselin	D. J. Shim
C. E. Guzman-Leong	S. Smith
K. Hasegawa	M. F. Uddin
P. H. Hoang	A. Udyawar
K. Hojo	T. V. Vo
D. N. Hopkins	K. Wang
E. J. Houston	B. Wasiluk
R. Janowiak	S. X. Xu

Working Group on Flaw Evaluation Reference Curves (BPV XI)

G. L. Stevens, <i>Chair</i>	A. Jenks
A. Udyawar, <i>Secretary</i>	V. Lacroix
W. H. Bamford	H. S. Mehta
M. L. Benson	K. Miyazaki
F. W. Brust	B. Pellereau
R. C. Cipolla	S. Ranganath
M. M. Farooq	D. A. Scarth
A. E. Freed	D. J. Shim
P. Gill	S. Smith
K. Hasegawa	T. V. Vo
K. Hojo	S. X. Xu
R. Janowiak	

Task Group on Code Case N-513 (WG-PFE) (BPV XI)

R. O. McGill, <i>Chair</i>	S. M. Parker
E. J. Houston, <i>Secretary</i>	D. Rudland
G. A. Antaki	P. J. Rush
R. C. Cipolla	D. A. Scarth
M. M. Farooq	S. X. Xu
R. Janowiak	

Task Group on Evaluation Procedures for Degraded Buried Pipe (WG-PFE) (BPV XI)

R. O. McGill, <i>Chair</i>	M. Kassab
S. X. Xu, <i>Secretary</i>	M. Moenssens
F. G. Abatt	D. P. Munson
G. A. Antaki	R. M. Pace
R. C. Cipolla	S. H. Pellet
R. G. Gilada	D. Rudland
K. Hasegawa	P. J. Rush
K. M. Hoffman	D. A. Scarth
R. Janowiak	

Working Group on Operating Plant Criteria (SG-ES) (BPV XI)

N. A. Palm, <i>Chair</i>	H. Kobayashi
A. E. Freed, <i>Secretary</i>	H. S. Mehta
K. R. Baker	A. D. Odell
W. H. Bamford	R. M. Pace
M. Brumovsky	J. C. Poehler
M. A. Erickson	S. Ranganath
T. J. Griesbach	W. L. Server
M. Hayashi	C. A. Tomes
R. Janowiak	A. Udyawar
M. Kirk	T. V. Vo
S. A. Kleinsmith	H. Q. Xu

Task Group on Flaw Evaluation for HDPE Pipe (WG-PFE) (BPV XI)

P. J. Rush, <i>Chair</i>	D. J. Shim
P. Krishnaswamy	M. Troughton
M. Moenssens	J. Wright
D. P. Munson	S. X. Xu
D. A. Scarth	

Task Group on Appendix L (WG-OPC) (BPV XI)

N. Glunt, <i>Chair</i>	C.-S. Oh
R. M. Pace, <i>Secretary</i>	H. Park
A. E. Freed	S. Ranganath
M. A. Gray	D. J. Shim
T. J. Griesbach	S. Smith
H. Nam	G. L. Stevens
A. Nana	A. Udyawar
A. D. Odell	

Subgroup on Nondestructive Examination (SG-NDE) (BPV XI)

J. T. Lindberg, <i>Chair</i>	J. Harrison
D. R. Cordes, <i>Secretary</i>	D. O. Henry
M. Briley	G. A. Lofthus
C. Brown	S. A. Sabo
T. L. Chan	F. J. Schaaf, Jr.
T. Cinson	R. V. Swain
S. E. Cumblidge	C. A. Nove, <i>Alternate</i>
K. J. Hacker	

Working Group on Personnel Qualification and Surface Visual and Eddy Current Examination (SG-NDE) (BPV XI)

C. Brown, *Chair*
T. Cinson, *Secretary*
J. E. Aycock
J. Bennett
S. E. Cumblidge
A. Diaz
N. Farenbaugh

D. O. Henry
J. T. Lindberg
C. Shinsky
R. Tedder
T. Thulien
J. T. Timm

Working Group on Procedure Qualification and Volumetric Examination (SG-NDE) (BPV XI)

G. A. Lofthus, *Chair*
J. Harrison, *Secretary*
M. Briley
A. Bushmire
D. R. Cordes
S. R. Doctor
K. J. Hacker
W. A. Jensen

D. A. Kull
C. Latiolais
C. A. Nove
S. A. Sabo
R. V. Swain
D. Van Allen
D. K. Zimmerman
B. Lin, *Alternate*

Subgroup on Repair/Replacement Activities (SG-RRA) (BPV XI)

S. L. McCracken, *Chair*
E. V. Farrell, Jr., *Secretary*
J. F. Ball
M. Brandes
S. B. Brown
R. Clow
P. D. Fisher
M. L. Hall
W. C. Holston
J. Honcharik
A. B. Meichler

B. R. Newton
S. A. Norman
J. E. O'Sullivan
G. C. Park
R. R. Stevenson
R. W. Swayne
D. J. Tilly
D. E. Waskey
J. G. Weicks
B. Lin, *Alternate*
J. K. Loy, *Alternate*

Working Group on Welding and Special Repair Processes (SG-RRA) (BPV XI)

J. G. Weicks, *Chair*
D. Barborak
S. J. Findlan
P. D. Fisher
R. C. Folley
M. L. Hall
W. C. Holston
J. Honcharik
C. C. Kim

M. Kris
S. E. Marlette
S. L. McCracken
B. R. Newton
J. E. O'Sullivan
D. J. Tilly
D. E. Waskey
J. K. Loy, *Alternate*

Task Group on Temper Bead Welding (BPV XI)

S. J. Findlan, *Chair*
D. Barborak
M. L. Hall
S. L. McCracken
N. Mohr
B. R. Newton
G. Olson

J. E. O'Sullivan
A. Patel
J. Tatman
D. J. Tilly
D. E. Waskey
J. G. Weicks

Task Group on Weld Overlay (BPV XI)

S. L. McCracken, *Chair*
D. Barborak
S. J. Findlan
M. L. Hall
W. C. Holston
S. Hunter
C. Lohse
S. E. Marlette

B. R. Newton
G. Olson
A. Patel
P. Raynaud
D. W. Sandusky
D. E. Waskey
J. G. Weicks

Working Group on Non-Metals Repair/Replacement Activities (SG-RRA) (BPV XI)

J. E. O'Sullivan, *Chair*
S. Schuessler, *Secretary*
M. Brandes
D. R. Dechene
J. Johnston, Jr.
B. Lin

M. P. Marohl
T. M. Musto
S. Patterson
A. Pridmore
F. J. Schaaf, Jr.
R. Stakenborghs

Task Group on HDPE Piping for Low Safety Significance Systems (WG-NMRA) (BPV XI)

M. Brandes, *Chair*
J. E. O'Sullivan, *Secretary*
M. Golliet
B. Lin

T. M. Musto
F. J. Schaaf, Jr.
S. Schuessler
R. Stakenborghs

Task Group on Repair by Carbon Fiber Composites (WGN-MRR) (BPV XI)

J. E. O'Sullivan, *Chair*
S. F. Arnold
S. W. Choi
D. R. Dechene
M. Golliet
L. S. Gordon
M. Kuntz
H. Lu
M. P. Marohl
L. Nadeau
C. A. Nove

R. P. Ojdrovic
A. Pridmore
P. Raynaud
S. Rios
C. W. Rowley
J. Sealey
R. Stakenborghs
N. Stoeva
M. F. Uddin
J. Wen
B. Davenport, *Alternate*

Working Group on Design and Programs (SG-RRA) (BPV XI)

S. B. Brown, *Chair*
A. B. Meichler, *Secretary*
O. Bhatta
R. Clow
R. R. Croft
E. V. Farrell, Jr.

B. Lin
H. Malikowski
G. C. Park
M. A. Pyne
R. R. Stevenson
R. W. Swayne

Task Group on Repair and Replacement Optimization (WG-D&P) (BPV XI)

S. L. McCracken, *Chair*
T. Basso
R. Clow
K. Dietrich
E. V. Farrell, Jr.
R. C. Folley
M. L. Hall
W. C. Holston

D. Jacobs
H. Malikowski
T. Nuoffer
G. C. Park
A. Patel
R. R. Stevenson
R. G. Weicks

Subgroup on Water-Cooled Systems (SG-WCS) (BPV XI)

M. J. Ferlisi, <i>Chair</i>	S. D. Kulat
J. Nygaard, <i>Secretary</i>	D. W. Lamond
J. M. Boughman	T. Nomura
S. B. Brown	T. Nuoffer
S. T. Chesworth	M. A. Pyne
H. Q. Do	H. M. Stephens, Jr.
K. W. Hall	R. Thames
P. J. Hennessey	M. Weis
K. M. Hoffman	M. J. Homiack, <i>Alternate</i>
A. E. Keyser	

Task Group on High Strength Nickel Alloys Issues (SG-WCS) (BPV XI)

H. Malikowski, <i>Chair</i>	S. E. Marlette
K. Dietrich, <i>Secretary</i>	B. L. Montgomery
W. H. Bamford	G. C. Park
T. Cinson	W. Sims
P. R. Donavin	D. E. Waskey
K. M. Hoffman	C. Wax
H. Kobayashi	K. A. Whitney
C. Lohse	

Working Group on Containment (SG-WCS) (BPV XI)

M. J. Ferlisi, <i>Chair</i>	J. A. Munshi
R. Thames, <i>Secretary</i>	M. Sircar
P. S. Ghosal	P. C. Smith
H. T. Hill	S. Walden
A. E. Keyser	M. Weis
B. Lehman	S. G. Brown, <i>Alternate</i>
P. Leininger	

Working Group on Inspection of Systems and Components (SG-WCS) (BPV XI)

H. Q. Do, <i>Chair</i>	J. Howard
M. Weis, <i>Secretary</i>	A. Keller
R. W. Blyde	S. D. Kulat
K. Caver	E. Lantz
C. Cueto-Felgueroso	A. Maekawa
M. J. Ferlisi	T. Nomura
M. L. Garcia Heras	J. C. Nygaard
K. W. Hall	S. Orita
K. M. Hoffman	

Working Group on Pressure Testing (SG-WCS) (BPV XI)

J. M. Boughman, <i>Chair</i>	D. W. Lamond
S. A. Norman, <i>Secretary</i>	J. K. McClanahan
T. Anselmi	T. P. McClure
B. Casey	B. L. Montgomery
Y.-K. Chung	M. Moenssens
M. J. Homiack	R. A. Nettles
A. E. Keyser	C. Thomas

Working Group on Risk-Informed Activities (SG-WCS) (BPV XI)

M. A. Pyne, <i>Chair</i>	S. D. Kulat
S. T. Chesworth, <i>Secretary</i>	D. W. Lamond
G. Brouette	G. J. Navratil
C. Cueto-Felgueroso	P. J. O'Regan
R. Haessler	N. A. Palm
J. Hakii	D. Vetter
K. W. Hall	J. C. Younger
M. J. Homiack	

Working Group on General Requirements (BPV XI)

T. Nuoffer, <i>Chair</i>	A. T. Roberts III
J. Mayo, <i>Secretary</i>	S. R. Scott
J. F. Ball	D. Vetter
T. L. Chan	S. E. Woolf
P. J. Hennessey	M. T. Audrain, <i>Alternate</i>
K. A. Kavanagh	R. S. Spencer, <i>Alternate</i>
T. N. Rezk	

Subgroup on Reliability and Integrity Management Program (SG-RIM) (BPV XI)

A. T. Roberts III, <i>Chair</i>	P. J. Hennessey
D. Vetter, <i>Secretary</i>	D. M. Jones
T. Anselmi	D. R. Lee
N. Broom	T. Lupold
V. Chugh	M. Orihuela
S. R. Doctor	F. J. Schaaf, Jr.
J. D. Fletcher	H. M. Stephens, Jr.
J. T. Fong	R. W. Swayne
J. Grimm	S. Takaya
K. Harris	R. Vayda

Working Group on MANDE (BPV XI)

H. M. Stephens, Jr., <i>Chair</i>	J. T. Fong
S. R. Doctor, <i>Vice Chair</i>	D. O. Henry
M. Turnbow, <i>Secretary</i>	T. Lupold
T. Anselmi	L. E. Mullins
N. A. Finney	M. Orihuela

JSME/ASME Joint Task Group for System-Based Code (SWG-RIM) (BPV XI)

S. Takaya, <i>Chair</i>	D. R. Lee
T. Asayama	H. Machida
S. R. Doctor	T. Muraki
K. Dozaki	A. T. Roberts III
J. T. Fong	F. J. Schaaf, Jr.
J. Hakii	R. Vayda
K. Harris	D. Watanabe
M. Hayashi	M. Morishita, <i>Contributing Member</i>
Y. Kamishima	

COMMITTEE ON TRANSPORT TANKS (BPV XII)

N. J. Paulick, <i>Chair</i>	T. A. Rogers
M. D. Rana, <i>Vice Chair</i>	R. C. Sallash
J. Oh, <i>Staff Secretary</i>	M. Shah
A. N. Antoniou	S. Staniszewski
P. Chilukuri	A. P. Varghese
W. L. Garfield	Y. Doron, <i>Contributing Member</i>
M. Pitts	R. Meyers, <i>Contributing Member</i>
J. Roberts	M. R. Ward, <i>Contributing Member</i>

Executive Committee (BPV XII)

M. D. Rana, <i>Chair</i>	T. A. Rogers
N. J. Paulick, <i>Vice Chair</i>	R. C. Sallash
J. Oh, <i>Staff Secretary</i>	S. Staniszewski
M. Pitts	A. P. Varghese

Subgroup on Design and Materials (BPV XII)

R. C. Sallash, *Chair*
 D. K. Chandiramani
 P. Chilukuri
 Y. Doron
 S. L. McWilliams
 N. J. Paulick
 M. D. Rana
 T. A. Rogers
 M. Shah
 S. Staniszewski

A. P. Varghese
 K. Xu
 A. T. Duggleby, *Contributing Member*
 R. D. Hayworth, *Contributing Member*
 G. G. Karcher, *Contributing Member*
 B. E. Spencer, *Contributing Member*
 M. R. Ward, *Contributing Member*
 J. Zheng, *Contributing Member*

Subgroup on Fabrication, Inspection, and Continued Service (BPV XII)

M. Pitts, *Chair*
 P. Chilukuri
 Y. Doron
 M. Koprivnak
 P. Miller
 O. Mulet
 J. Roberts

T. A. Rogers
 R. C. Sallash
 L. Selensky
 S. Staniszewski
 R. D. Hayworth
 G. McRae, *Contributing Member*

Subgroup on General Requirements (BPV XII)

S. Staniszewski, *Chair*
 B. F. Pittel, *Secretary*
 A. N. Antoniou
 Y. Doron
 H. Ebben III
 J. L. Freiler
 W. L. Garfield
 O. Mulet
 M. Pitts

R. C. Sallash
 L. Selensky
 P. Chilukuri, *Contributing Member*
 T. J. Hitchcock, *Contributing Member*
 S. L. McWilliams, *Contributing Member*
 T. A. Rogers, *Contributing Member*
 D. G. Shelton, *Contributing Member*
 M. R. Ward, *Contributing Member*

Subgroup on Nonmandatory Appendices (BPV XII)

T. A. Rogers, *Chair*
 S. Staniszewski, *Secretary*
 P. Chilukuri
 N. J. Paulick

M. Pitts
 R. C. Sallash
 D. G. Shelton
 Y. Doron, *Contributing Member*

COMMITTEE ON OVERPRESSURE PROTECTION (BPV XIII)

D. B. DeMichael, *Chair*
 D. Miller, *Vice Chair*
 C. E. O'Brien, *Staff Secretary*
 J. F. Ball
 J. Burgess
 B. Calderon
 J. W. Dickson
 A. Donaldson
 S. F. Harrison, Jr.
 B. K. Nutter
 T. Patel
 M. Poehlmann
 T. R. Tarbay
 D. E. Tompkins
 Z. Wang
 J. A. West
 A. Wilson
 H. Aguilar, *Contributing Member*

R. W. Barnes, *Contributing Member*
 R. D. Danzy, *Contributing Member*
 M. Elias, *Contributing Member*
 D. Felix, *Contributing Member*
 A. Frigerio, *Contributing Member*
 J. P. Glaspie, *Contributing Member*
 A. Hassan, *Contributing Member*
 P. K. Lam, *Contributing Member*
 J. M. Levy, *Contributing Member*
 M. Mengon, *Contributing Member*
 J. Mize, *Contributing Member*
 M. Mullavey, *Contributing Member*
 S. K. Parimi, *Contributing Member*
 R. Raman, *Contributing Member*
 M. Reddy, *Contributing Member*
 S. Ruesenberg, *Contributing Member*
 K. Shores, *Contributing Member*
 D. E. Tezzo, *Contributing Member*

Executive Committee (BPV XIII)

D. Miller, *Chair*
 D. B. DeMichael, *Vice Chair*
 C. E. O'Brien, *Staff Secretary*
 J. F. Ball

A. Donaldson
 B. K. Nutter
 J. A. West

Subgroup on Design and Materials (BPV XIII)

D. Miller, *Chair*
 T. Patel, *Vice Chair*
 B. Mruk, *Secretary*
 C. E. Bear
 A. Biesecker
 W. E. Chapin
 J. L. Freiler
 B. Joergensen
 V. Kalyanasundaram
 B. J. Mollitor
 A. Swearingin

T. R. Tarbay
 J. A. West
 A. Williams
 D. J. Azukas, *Contributing Member*
 R. D. Danzy, *Contributing Member*
 A. Hassan, *Contributing Member*
 R. Miyata, *Contributing Member*
 M. Mullavey, *Contributing Member*
 S. K. Parimi, *Contributing Member*
 G. Ramirez, *Contributing Member*
 K. Shores, *Contributing Member*

Subgroup on General Requirements (BPV XIII)

A. Donaldson, *Chair*
 B. F. Pittel, *Vice Chair*
 J. M. Levy, *Secretary*
 D. J. Azukas
 J. F. Ball
 M. Z. Brown
 J. Burgess
 D. B. DeMichael
 M. Elias
 S. T. French
 J. Gillham
 R. Klimas, Jr.
 Z. E. Kumana
 P. K. Lam
 K. R. May
 J. Mize
 L. Moedinger
 M. Mullavey
 M. Poehlmann
 K. Shores
 D. E. Tezzo
 D. E. Tompkins
 J. F. White

B. Calderon, *Contributing Member*
 P. Chavdarov, *Contributing Member*
 T. M. Fabiani, *Contributing Member*
 J. L. Freiler, *Contributing Member*
 J. P. Glaspie, *Contributing Member*
 G. D. Goodson, *Contributing Member*
 C. Haldiman, *Contributing Member*
 J. Horne, *Contributing Member*
 B. Joergensen, *Contributing Member*
 C. Lasarte, *Contributing Member*
 D. Mainiero-Cessna, *Contributing Member*
 M. Mengon, *Contributing Member*
 D. E. Miller, *Contributing Member*
 R. Miyata, *Contributing Member*
 B. Mruk, *Contributing Member*
 R. Raman, *Contributing Member*
 M. Reddy, *Contributing Member*
 S. Ruesenberg, *Contributing Member*
 R. Sadowski, *Contributing Member*
 A. Swearingin, *Contributing Member*
 A. P. Varghese, *Contributing Member*

Subgroup on Nuclear (BPV XIII)

J. F. Ball, *Chair*
 K. R. May, *Vice Chair*
 R. Krithivasan, *Secretary*
 J. W. Dickson
 S. Jones
 R. Lack
 D. Miller
 T. Patel

K. Shores
 I. H. Tseng
 J. Yu
 N. J. Hansing, *Alternate*
 J. M. Levy, *Alternate*
 B. J. Yonsky, *Alternate*
 S. T. French, *Contributing Member*
 D. B. Ross, *Contributing Member*

Subgroup on Testing (BPV XIII)

B. K. Nutter, <i>Chair</i>	A. Strecker
T. P. Beirne, <i>Vice Chair</i>	J. R. Thomas, Jr.
J. W. Dickson, <i>Secretary</i>	Z. Wang
B. Calderon	A. Wilson
V. Chicola III	D. Nelson, <i>Alternate</i>
B. Engman	J. Cockerham, <i>Contributing Member</i>
R. J. Garnett	J. Mize, <i>Contributing Member</i>
R. Houk	M. Mullavey, <i>Contributing Member</i>
R. Lack	R. Raman, <i>Contributing Member</i>
M. Mengon	S. Ruesenberg, <i>Contributing Member</i>
C. Sharpe	K. Shores, <i>Contributing Member</i>

US TAG to ISO TC 185 Safety Devices for Protection Against Excessive Pressure (BPV XIII)

D. Miller, <i>Chair</i>	B. K. Nutter
C. E. O'Brien, <i>Staff Secretary</i>	T. Patel
J. F. Ball	J. R. Thomas, Jr.
T. J. Bevilacqua	J. A. West
D. B. DeMichael	J. F. White
J. W. Dickson	

COMMITTEE ON BOILER AND PRESSURE VESSEL CONFORMITY ASSESSMENT (CBPVCA)

R. V. Wielgoszinski, <i>Chair</i>	T. P. Beirne, <i>Alternate</i>
G. Scribner, <i>Vice Chair</i>	M. Blankinship, <i>Alternate</i>
P. Murray, <i>Staff Secretary</i>	J. W. Dickson, <i>Alternate</i>
J. P. Chicoine	J. M. Downs, <i>Alternate</i>
P. D. Edwards	B. J. Hackett, <i>Alternate</i>
T. E. Hansen	W. Hibdon, <i>Alternate</i>
B. L. Krasium	Y.-S. Kim, <i>Alternate</i>
P. F. Martin	B. Morelock, <i>Alternate</i>
L. E. McDonald	M. Poehlmann, <i>Alternate</i>
D. Miller	R. Rockwood, <i>Alternate</i>
I. Powell	B. C. Turczynski, <i>Alternate</i>
L. Skarin	D. E. Tuttle, <i>Alternate</i>
R. Uebel	S. V. Voorhees, <i>Alternate</i>
E. A. Whittle	D. Cheetham, <i>Contributing Member</i>
P. Williams	A. J. Spencer, <i>Honorary Member</i>

COMMITTEE ON NUCLEAR CERTIFICATION (CNC)

R. R. Stevenson, <i>Chair</i>	E. A. Whittle
J. DeKleine, <i>Vice Chair</i>	T. Aldo, <i>Alternate</i>
Z. McLucas, <i>Staff Secretary</i>	M. Blankinship, <i>Alternate</i>
J. F. Ball	P. J. Coco, <i>Alternate</i>
G. Claffey	N. DeSantis, <i>Alternate</i>
G. Gobbi	C. Dinic, <i>Alternate</i>
S. M. Goodwin	P. D. Edwards, <i>Alternate</i>
J. W. Highlands	T. B. Franchuk, <i>Alternate</i>
K. A. Kavanagh	K. M. Hottle, <i>Alternate</i>
J. C. Krane	P. Krane, <i>Alternate</i>
M. A. Lockwood	D. Nenstiel, <i>Alternate</i>
T. McGee	L. Ponce, <i>Alternate</i>
E. L. Pleins	P. F. Prescott, <i>Alternate</i>
T. E. Quaka	S. V. Voorhees, <i>Alternate</i>
T. N. Rezk	M. Wilson, <i>Alternate</i>
G. E. Szabatura	S. Yang, <i>Alternate</i>
C. Turylo	S. F. Harrison, Jr., <i>Contributing Member</i>
D. M. Vickery	

ORGANIZATION OF SECTION III

1 GENERAL

Section III consists of Division 1, Division 2, Division 3, and Division 5. These Divisions are broken down into Subsections and are designated by capital letters preceded by the letter “N” for Division 1, by the letter “C” for Division 2, by the letter “W” for Division 3, and by the letter “H” for Division 5. Each Subsection is published separately, with the exception of those listed for Divisions 2, 3, and 5.

- Subsection NCA — General Requirements for Division 1 and Division 2
- Appendices
- Division 1
 - Subsection NB — Class 1 Components
 - Subsection NCD — Class 2 and Class 3 Components*
 - Subsection NE — Class MC Components
 - Subsection NF — Supports
 - Subsection NG — Core Support Structures
- Division 2 — Code for Concrete Containments
 - Subsection CC — Concrete Containments
- Division 3 — Containment Systems for Transportation and Storage of Spent Nuclear Fuel and High-Level Radioactive Material
 - Subsection WA — General Requirements for Division 3
 - Subsection WB — Class TC Transportation Containments
 - Subsection WC — Class SC Storage Containments
 - Subsection WD — Class ISS Internal Support Structures
- Division 5 — High Temperature Reactors
 - Subsection HA — General Requirements
 - Subpart A — Metallic Materials
 - Subpart B — Graphite Materials
 - Subpart C — Composite Materials
 - Subsection HB — Class A Metallic Pressure Boundary Components
 - Subpart A — Low Temperature Service
 - Subpart B — Elevated Temperature Service
 - Subsection HC — Class B Metallic Pressure Boundary Components
 - Subpart A — Low Temperature Service
 - Subpart B — Elevated Temperature Service
 - Subsection HF — Class A and B Metallic Supports
 - Subpart A — Low Temperature Service
 - Subsection HG — Class SM Metallic Core Support Structures
 - Subpart A — Low Temperature Service
 - Subpart B — Elevated Temperature Service
 - Subsection HH — Class SN Nonmetallic Core Components
 - Subpart A — Graphite Materials
 - Subpart B — Composite Materials

* In the 2021 Edition, Subsections NC and ND have been incorporated into one publication, Subsection NCD (BPVC.III.1.NCD), Class 2 and Class 3 Components.

2 SUBSECTIONS

Subsections are divided into Articles, subarticles, paragraphs, and, where necessary, subparagraphs and subsubparagraphs.

3 ARTICLES

Articles are designated by the applicable letters indicated above for the Subsections followed by Arabic numbers, such as NB-1000. Where possible, Articles dealing with the same topics are given the same number in each Subsection, except NCA, in accordance with the following general scheme:

Article Number	Title
1000	Introduction or Scope
2000	Material
3000	Design
4000	Fabrication and Installation
5000	Examination
6000	Testing
7000	Overpressure Protection
8000	Nameplates, Stamping With Certification Mark, and Reports

The numbering of Articles and the material contained in the Articles may not, however, be consecutive. Due to the fact that the complete outline may cover phases not applicable to a particular Subsection or Article, the rules have been prepared with some gaps in the numbering.

4 SUBARTICLES

Subarticles are numbered in units of 100, such as NB-1100.

5 SUBSUBARTICLES

Subsubarticles are numbered in units of 10, such as NB-2130, and generally have no text. When a number such as NB-1110 is followed by text, it is considered a paragraph.

6 PARAGRAPHS

Paragraphs are numbered in units of 1, such as NB-2121.

7 SUBPARAGRAPHS

Subparagraphs, when they are *major* subdivisions of a paragraph, are designated by adding a decimal followed by one or more digits to the paragraph number, such as NB-1132.1. When they are *minor* subdivisions of a paragraph, subparagraphs may be designated by lowercase letters in parentheses, such as NB-2121(a).

8 SUBSUBPARAGRAPHS

Subsubparagraphs are designated by adding lowercase letters in parentheses to the *major* subparagraph numbers, such as NB-1132.1(a). When further subdivisions of *minor* subparagraphs are necessary, subsubparagraphs are designated by adding Arabic numerals in parentheses to the subparagraph designation, such as NB-2121(a)(1).

9 REFERENCES

References used within Section III generally fall into one of the following four categories:

(a) *References to Other Portions of Section III.* When a reference is made to another Article, subarticle, or paragraph, all numbers subsidiary to that reference shall be included. For example, reference to Article NB-3000 includes all material in Article NB-3000; reference to NB-3100 includes all material in subarticle NB-3100; reference to NB-3110 includes all paragraphs, NB-3111 through NB-3113.

(b) *References to Other Sections.* Other Sections referred to in Section III are the following:

(1) *Section II, Materials.* When a requirement for a material, or for the examination or testing of a material, is to be in accordance with a specification such as SA-105, SA-370, or SB-160, the reference is to material specifications in Section II. These references begin with the letter “S.”

(2) *Section V, Nondestructive Examination.* Section V references begin with the letter “T” and relate to the non-destructive examination of material or welds.

(3) *Section IX, Welding and Brazing Qualifications.* Section IX references begin with the letter “Q” and relate to welding and brazing requirements.

(4) *Section XI, Rules for Inservice Inspection of Nuclear Power Plant Components.* When a reference is made to in-service inspection, the rules of Section XI shall apply.

(c) *Reference to Specifications and Standards Other Than Published in Code Sections*

(1) Specifications for examination methods and acceptance standards to be used in connection with them are published by the American Society for Testing and Materials (ASTM). At the time of publication of Section III, some such specifications were not included in Section II of this Code. A reference to ASTM E94 refers to the specification so designated by and published by ASTM, 100 Barr Harbor Drive, West Conshohocken, PA 19428.

(2) Dimensional standards covering products such as valves, flanges, and fittings are sponsored and published by The American Society of Mechanical Engineers and approved by the American National Standards Institute. ** When a product is to conform to such a standard, for example ASME B16.5, the standard is approved by the American National Standards Institute. The applicable year of issue is that suffixed to its numerical designation in Table NCA-7100-1, for example ASME B16.5-2003. Standards published by The American Society of Mechanical Engineers are available from ASME (<https://www.asme.org/>).

(3) Dimensional and other types of standards covering products such as valves, flanges, and fittings are also published by the Manufacturers Standardization Society of the Valve and Fittings Industry and are known as Standard Practices. When a product is required by these rules to conform to a Standard Practice, for example MSS SP-100, the Standard Practice referred to is published by the Manufacturers Standardization Society of the Valve and Fittings Industry, Inc. (MSS), 127 Park Street, NE, Vienna, VA 22180. The applicable year of issue of such a Standard Practice is that suffixed to its numerical designation in Table NCA-7100-1, for example MSS SP-58-2009.

(4) Specifications for welding and brazing materials are published by the American Welding Society (AWS), 8669 NW 36 Street, No. 130, Miami, FL 33166. Specifications of this type are incorporated in Section II and are identified by the AWS designation with the prefix “SF,” for example SFA-5.1.

(5) Standards applicable to the design and construction of tanks and flanges are published by the American Petroleum Institute and have designations such as API-605. When documents so designated are referred to in Section III, for example API-605-1988, they are standards published by the American Petroleum Institute and are listed in Table NCA-7100-1.

(d) *References to Appendices.* Section III uses two types of appendices that are designated as either Section III Appendices or Subsection Appendices. Either of these appendices is further designated as either Mandatory or Nonmandatory for use. Mandatory Appendices are referred to in the Section III rules and contain requirements that must be followed in construction. Nonmandatory Appendices provide additional information or guidance when using Section III.

(1) Section III Appendices are contained in a separate book titled “Appendices.” These appendices have the potential for multiple subsection applicability. Mandatory Appendices are designated by a Roman numeral followed, when appropriate, by Arabic numerals to indicate various articles, subarticles, and paragraphs of the appendix, such as II-1500 or XIII-1210. Nonmandatory Appendices are designated by a capital letter followed, when appropriate, by Arabic numerals to indicate various articles, subarticles, and paragraphs of the appendix, such as D-1200 or Y-1440.

**The American National Standards Institute (ANSI) was formerly known as the American Standards Association. Standards approved by the Association were designated by the prefix “ASA” followed by the number of the standard and the year of publication. More recently, the American National Standards Institute was known as the United States of America Standards Institute. Standards were designated by the prefix “USAS” followed by the number of the standard and the year of publication. While the letters of the prefix have changed with the name of the organization, the numbers of the standards have remained unchanged.

(2) Subsection Appendices are specifically applicable to just one subsection and are contained within that subsection. Subsection-specific mandatory and nonmandatory appendices are numbered in the same manner as Section III Appendices, but with a subsection identifier (e.g., NF, NH, D2, etc.) preceding either the Roman numeral or the capital letter for a unique designation. For example, NF-II-1100 or NF-A-1200 would be part of a Subsection NF mandatory or nonmandatory appendix, respectively. For Subsection CC, D2-IV-1120 or D2-D-1330 would be part of a Subsection CC mandatory or nonmandatory appendix, respectively.

(3) It is the intent of this Section that the information provided in both Mandatory and Nonmandatory Appendices may be used to meet the rules of any Division or Subsection. In case of conflict between Appendix rules and Division/Subsection rules, the requirements contained in the Division/Subsection shall govern. Additional guidance on Appendix usage is provided in the front matter of Section III Appendices.

SUMMARY OF CHANGES

Errata to the BPV Code may be posted on the ASME website to provide corrections to incorrectly published items, or to correct typographical or grammatical errors in the BPV Code. Such Errata shall be used on the date posted.

Information regarding Special Notices and Errata is published by ASME at <http://go.asme.org/BPVCerrata>.

Changes given below are identified on the pages by a margin note, **(21)**, placed next to the affected area.

<i>Page</i>	<i>Location</i>	<i>Change</i>
vii	List of Sections	(1) Listing for Section III updated (2) Section XIII added (3) Code Case information updated
ix	Foreword	(1) Subparagraph (k) added and subsequent subparagraph redesignated (2) Second footnote revised (3) Last paragraph added
xii	Submittal of Technical Inquiries to the Boiler and Pressure Vessel Standards Committees	Paragraphs 1(a)(3)(-b), 2(b), and 5(a)(3) revised
xv	Personnel	Updated
xxxvi	Organization of Section III	(1) In para. 1, Division 1 listing updated (2) In para. 9(c)(3), "MSS SP-89-2003" corrected by errata to "MSS SP-58-2009"
1	NE-1130	In subpara. (c), cross-reference to NCA updated
12	NE-2160	Cross-reference to NCA updated
30	Figure NE-2575.2-1	General Note (c) added
34	NE-3113	Cross-reference to NCA updated
57	NE-3228.1	(1) In first paragraph, last line revised (2) Subparagraph (a) deleted and subsequent subparagraphs redesignated
89	NE-4211	Revised
125	NE-6111	Revised
131	NE-7512.2	Cross-reference to NCA updated
132	NE-7513	Revised
132	NE-7521	In subpara. (b), cross-references to NCA updated
132	NE-7700	(1) In NE-7710, subpara. (a) revised (2) NE-7720 and NE-7730 deleted

LIST OF CHANGES IN RECORD NUMBER ORDER

DELETED

CROSS-REFERENCING AND STYLISTIC CHANGES IN THE BOILER AND PRESSURE VESSEL CODE

There have been structural and stylistic changes to BPVC, starting with the 2011 Addenda, that should be noted to aid navigating the contents. The following is an overview of the changes:

Subparagraph Breakdowns/Nested Lists Hierarchy

- First-level breakdowns are designated as (a), (b), (c), etc., as in the past.
- Second-level breakdowns are designated as (1), (2), (3), etc., as in the past.
- Third-level breakdowns are now designated as (-a), (-b), (-c), etc.
- Fourth-level breakdowns are now designated as (-1), (-2), (-3), etc.
- Fifth-level breakdowns are now designated as (+a), (+b), (+c), etc.
- Sixth-level breakdowns are now designated as (+1), (+2), etc.

Footnotes

With the exception of those included in the front matter (roman-numbered pages), all footnotes are treated as endnotes. The endnotes are referenced in numeric order and appear at the end of each BPVC section/subsection.

Submittal of Technical Inquiries to the Boiler and Pressure Vessel Standards Committees

Submittal of Technical Inquiries to the Boiler and Pressure Vessel Standards Committees has been moved to the front matter. This information now appears in all Boiler Code Sections (except for Code Case books).

Cross-References

It is our intention to establish cross-reference link functionality in the current edition and moving forward. To facilitate this, cross-reference style has changed. Cross-references within a subsection or subarticle will not include the designator/identifier of that subsection/subarticle. Examples follow:

- *(Sub-)Paragraph Cross-References.* The cross-references to subparagraph breakdowns will follow the hierarchy of the designators under which the breakdown appears.
 - If subparagraph (-a) appears in X.1(c)(1) and is referenced in X.1(c)(1), it will be referenced as (-a).
 - If subparagraph (-a) appears in X.1(c)(1) but is referenced in X.1(c)(2), it will be referenced as (1)(-a).
 - If subparagraph (-a) appears in X.1(c)(1) but is referenced in X.1(e)(1), it will be referenced as (c)(1)(-a).
 - If subparagraph (-a) appears in X.1(c)(1) but is referenced in X.2(c)(2), it will be referenced as X.1(c)(1)(-a).
- *Equation Cross-References.* The cross-references to equations will follow the same logic. For example, if eq. (1) appears in X.1(a)(1) but is referenced in X.1(b), it will be referenced as eq. (a)(1)(1). If eq. (1) appears in X.1(a)(1) but is referenced in a different subsection/subarticle/paragraph, it will be referenced as eq. X.1(a)(1)(1).

ARTICLE NE-1000

INTRODUCTION

NE-1100 SCOPE AND GENERAL REQUIREMENTS

NE-1110 ASPECTS OF CONSTRUCTION COVERED BY THESE RULES

(a) Subsection NE establishes rules for material, design, fabrication, examination, inspection, testing, and preparation of reports for metal containment vessels.

(b) Class MC containment vessels shall be constructed in accordance with the rules of this Subsection, except as provided in NCA-2134(c). Only containment vessels and their appurtenances shall be classified as Class MC. Piping, pumps, and valves that are part of the containment system (NE-1130) or which penetrate or are attached to the containment vessel shall be classified as Class 1 or Class 2 by the Design Specification and meet the requirements of the applicable Subsection. Figure NE-1110-1 shows some typical penetrations with different Class designations.

(c) Subsection NE does not contain rules to cover all details of construction of Class MC containment vessels. The Certificate Holder shall provide details of construction that will be consistent with those provided by the rules of this Subsection. These details of construction shall be subject to the approval of the Owner or his designee, and acceptance by the Inspector.

NE-1120 TEMPERATURE LIMITS

The rules of Subsection NE shall not be used for items that are to be subjected to metal temperatures that exceed the temperature limit in the applicability column shown in Section II, Part D, Subpart 1, Tables 1A, 1B, and 3 for design stress values, or in Section II, Part D, Subpart 1, Tables 2A, 2B, and 4 for design stress intensity values. Above those temperatures, the creep and stress rupture characteristics of materials permitted to be used become significant factors, which are not presently covered by the rules of this Subsection. Fatigue design curves and specified methods for fatigue analysis are not applicable above 700°F (370°C) for materials covered by Section III Appendices, Mandatory Appendix I, Figures I-9.1 and I-9.4 and above 800°F (425°C) for materials covered by Section III Appendices, Mandatory Appendix I, Figures I-9.2 and I-9.3.

NE-1130 BOUNDARIES OF JURISDICTION

(21)

The containment system includes (a) through (c) as follows:

(a) the containment vessel;

(b) all penetration assemblies or appurtenances attached to the containment vessel;

(c) all piping, pumps, and valves attached to the containment vessel, or to penetration assemblies out to and including any valves required to isolate the system and provide a pressure boundary for the containment function. Classification of such items shall be given in the Design Specifications (NCA-3211.19 and NE-1110).

NE-1131 Boundaries of the Containment Vessel

The Design Specification shall define the boundary of a containment vessel to which piping or another component is attached. Figure NE-1131-1 shows typical jurisdictional boundaries. The boundary shall not be closer to the containment vessel than:

(a) the first circumferential joint in welded connections (the connecting weld shall be considered part of the piping);

(b) the face of the first flange in bolted connections (the bolts shall be considered part of the piping);

(c) the first threaded joint in screwed connections.

NE-1132 Boundary Between Containment Vessel and Attachments

NE-1132.1 Attachments.

(a) An attachment is an element in contact with or connected to the inside or outside of the pressure-retaining portion of a containment vessel.

(b) Attachments may have either a pressure-retaining function or a non-pressure-retaining function.

(1) Attachments with a pressure-retaining function include items such as:

(-a) pressure boundary stiffeners;

(-b) vessel opening reinforcement.

(2) Attachments with non-pressure-retaining function include items such as:

(-a) thermal sleeves and turning vanes;

(-b) vessel saddles, support and shear lugs, brackets, skirts, and other items within the containment vessel support load path.

(c) Attachments may also have either a structural or nonstructural function.

(1) Attachments with a structural function (structural attachments):

(-a) perform a pressure-retaining function;

(-b) are in the containment vessel support load path.

(2) Attachments with a nonstructural function (nonstructural attachments):

(-a) do not perform a pressure-retaining function;

(-b) are not in the containment vessel support load path;

(-c) may be permanent or temporary.

Nonstructural attachments include items such as nameplates, insulation supports, and locating and lifting lugs.

NE-1132.2 Jurisdictional Boundary. The jurisdictional boundary between the containment vessel and an attachment defined in the Design Specification shall not be any closer to the pressure-retaining portion of the vessel than as defined in (a) through (g) below. Figures NE-1132.2-1, NE-1132.2-2, and NE-1132.2-3 are provided as an aid in defining the boundary and construction requirements of this Subsection.

(a) Attachments cast or forged with the containment vessel and weld buildup on the vessel surface shall be considered part of the containment vessel.

(b) Attachments, welds, and fasteners having a pressure-retaining function shall be considered part of the containment vessel.

(c) Except as provided in (d) and (e) below, the boundary between the containment vessel and an attachment not having a pressure-retaining function shall be at the surface of the vessel.

(d) The first connecting weld of a non-pressure-retaining structural attachment to the containment vessel shall be considered part of the vessel unless the weld is more than $2t$ from the pressure-retaining portion of the vessel, where t is the nominal thickness of the pressure-retaining material. Beyond $2t$ from the pressure-retaining portion of the vessel, the first weld shall be considered part of the attachment.

(e) The first connecting weld of a welded nonstructural attachment to the containment vessel shall be considered part of the attachment. At or within $2t$ from the pressure-retaining portion of the component the first connecting weld shall conform to NE-4430.

(f) Mechanical fasteners used to connect a non-pressure-retaining attachment to the containment vessel shall be considered part of the attachment.

(g) The boundary may be located further from the pressure-retaining portion of the containment vessel than as defined in (a) through (f) above when specified in the Design Specification.

**Figure NE-1110-1
Typical Containment Penetrations**

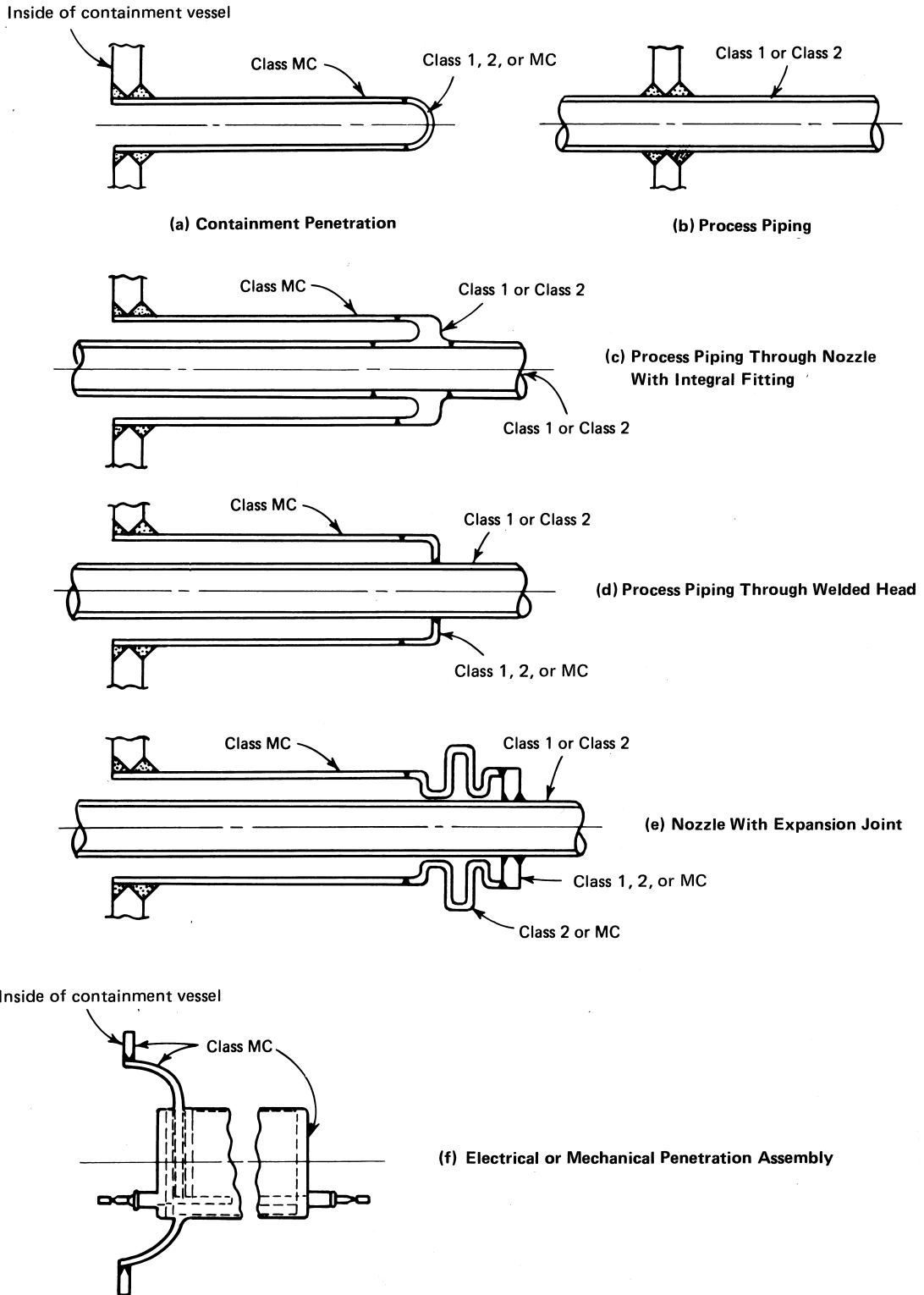

Figure NE-1131-1
Some Typical Jurisdictional Boundaries for Welded Connections Class MC Containment Vessels

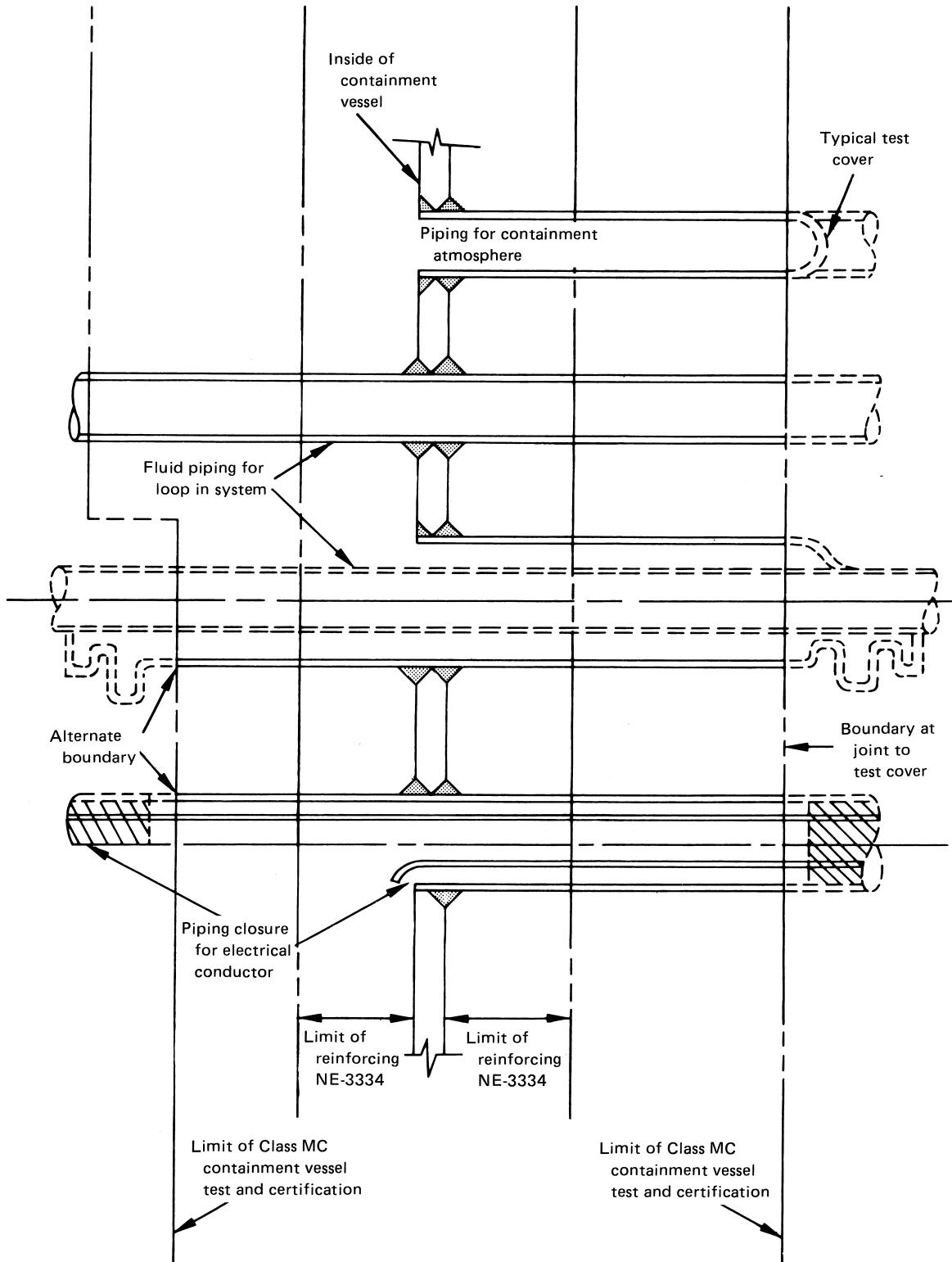
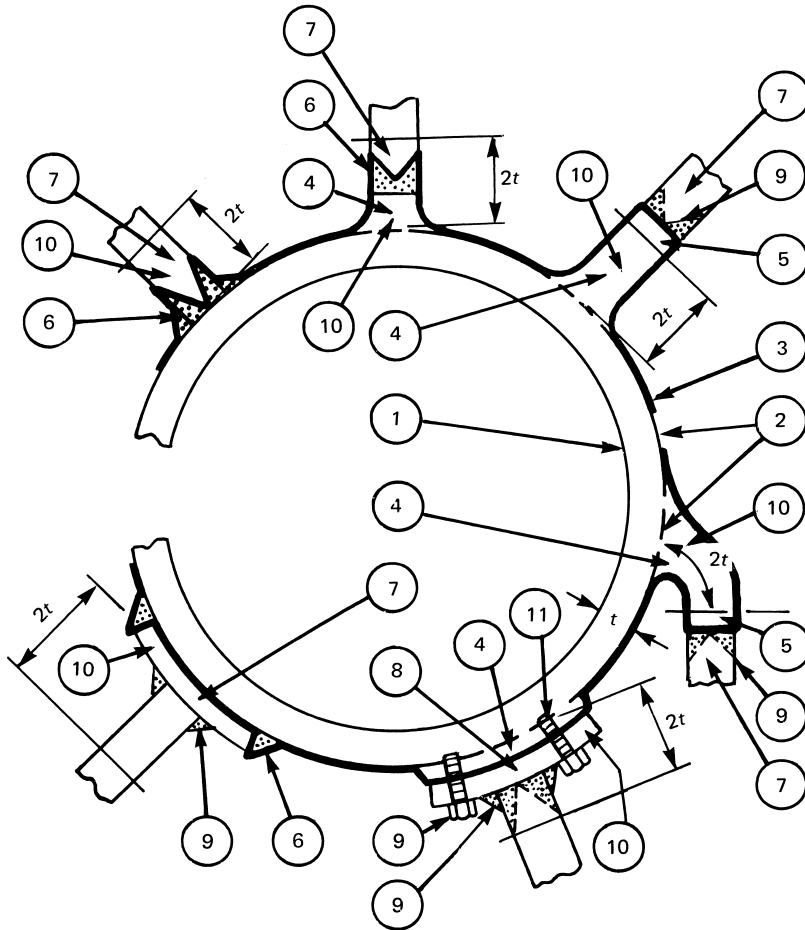

Figure NE-1132.2-1
Attachments in the Containment Vessel Support Load Path That Do Not Perform a Pressure-Retaining Function



- ① Containment vessel shall conform to Subsection NE.
- ② Pressure-retaining portion of the containment vessel.
- ③ Jurisdictional boundary (heavy line).
- ④ Cast or forged attachment or weld buildup shall conform to Subsection NE.
- ⑤ Beyond $2t$ from the pressure-retaining portion of the containment vessel, the design rules of Article NF-3000 may be used as a substitute for the design rules of Article NE-3000.
- ⑥ At or within $2t$ from the pressure-retaining portion of the containment vessel, the first connecting weld shall conform to Subsection NE.
- ⑦ Beyond $2t$ from the pressure-retaining portion of the containment vessel or beyond the first connecting weld, the attachment shall conform to Subsection NF [Note (1)].
- ⑧ Bearing, clamped, or fastened attachment shall conform to Subsection NF [Note (1)].
- ⑨ Attachment connection shall conform to Subsection NF [Note (1)].
- ⑩ At or within $2t$ from the pressure-retaining portion of the containment vessel, the interaction effects of the attachment shall be considered in accordance with NE-3135.
- ⑪ Drilled holes shall conform to Subsection NE.

GENERAL NOTE: These sketches are intended to show jurisdictional concepts and should not be considered as recommended configurations.

NOTE: (1) If the attachment is an intervening element [NF-1110(c)], material, design, and connections, as appropriate, are outside Code jurisdiction.

Figure NE-1132.2-2
Attachments That Do Not Perform a Pressure-Retaining Function and Are Not in the Containment Vessel Support Load Path (Nonstructural Attachments)

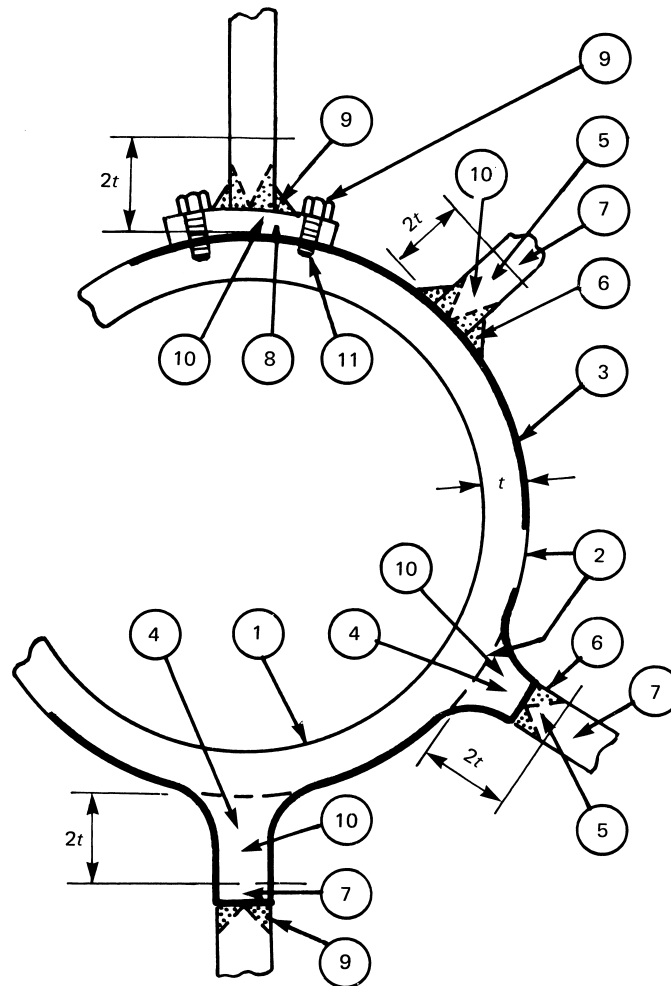

- ① Containment vessel shall conform to Subsection NE.
- ② Pressure-retaining portion of the containment vessel.
- ③ Jurisdictional boundary (heavy line).
- ④ Cast or forged attachment or weld buildup shall conform to Subsection NE.
- ⑤ At or within $2t$ from the pressure-retaining portion of the containment vessel, the material of the first welded nonstructural attachment shall conform to NE-2190; design is outside Code jurisdiction.
- ⑥ At or within $2t$ from the pressure-retaining portion of the containment vessel, the first connecting weld shall conform to NE-4430.
- ⑦ Beyond $2t$ from the pressure-retaining portion of the containment vessel, the nonstructural attachment is outside Code jurisdiction.
- ⑧ Bearing, clamped, or fastened nonstructural attachment is outside Code jurisdiction.
- ⑨ Nonstructural attachment connection is outside Code jurisdiction.
- ⑩ At or within $2t$ from the pressure-retaining portion of the containment vessel, the interaction effects of the nonstructural attachment shall be considered in accordance with NE-3135.
- ⑪ Drilled holes shall conform to Subsection NE.

GENERAL NOTE: These sketches are intended to show jurisdictional concepts and should not be considered as recommended configurations.

Figure NE-1132.2-3
Attachments That Perform a Pressure-Retaining Function

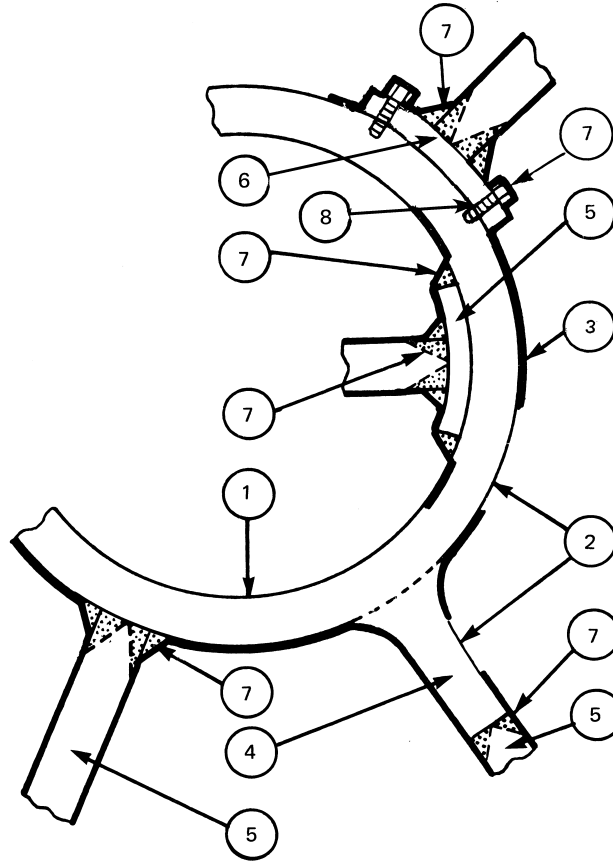

- ① Containment vessel shall conform to Subsection NE.
- ② Pressure-retaining portion of the containment vessel.
- ③ Jurisdictional boundary (heavy line).
- ④ Cast or forged attachment or weld buildup shall conform to Subsection NE.
- ⑤ Welded attachment shall conform to Subsection NE.
- ⑥ Bearing, clamped, or fastened attachment shall conform to Subsection NE.
- ⑦ Attachment connection shall conform to Subsection NE.
- ⑧ Drilled holes shall conform to Subsection NE.

GENERAL NOTE: These sketches are intended to show jurisdictional concepts and should not be considered as recommended configurations.

ARTICLE NE-2000 MATERIAL

NE-2100 GENERAL REQUIREMENTS FOR MATERIAL

NE-2110 SCOPE OF PRINCIPAL TERMS EMPLOYED

(a) The term *material* as used in this Subsection is defined in NCA-1220. The term *Material Organization* is defined in Article NCA-9000.

(b) The term *pressure-retaining material* as used in this Subsection applies to items such as vessel shells, heads, and nozzles; pipes, tubes, and fittings; and bolting that joins pressure-retaining items.

(c) The requirements of this Article make reference to the term *thickness*. For the purpose intended, the following definitions of nominal thickness apply:

(1) *plate* — the thickness is the dimension of the short transverse direction

(2) *forgings* — the thickness is the dimension defined as follows:

(-a) *hollow forgings* — the nominal thickness is measured between the inside and outside surfaces (radial thickness)

(-b) *disk forgings* (axial length less than the outside diameter) — the nominal thickness is the axial length

(-c) *flat ring forgings* (axial length less than the radial thickness) — for axial length ≤ 2 in. (50 mm), the axial length is the nominal thickness. For axial length > 2 in. (50 mm), the radial thickness is the nominal thickness.

(-d) *rectangular solid forgings* — the least rectangular dimension is the nominal thickness

(3) castings

(-a) Thickness t for fracture toughness testing is defined as the nominal pipe wall thickness of the connecting piping.

(-b) Thickness t for heat treatment purposes is defined as the thickness of the pressure-retaining wall of the casting, excluding flanges and sections designated by the designer as nonpressure retaining.

NE-2120 PRESSURE-RETAINING MATERIAL

NE-2121 Permitted Material Specifications

(a) Pressure-retaining material shall conform to the requirements of one of the specifications for materials given in Tables NE-2121(a)-1 and NE-2121(a)-2, including all applicable footnotes in Section II, Part D, Subpart 1,

Tables 1A, 1B, and 3, and to all of the requirements of this Article which apply to the product form in which the material is used. Attachments which perform a pressure-retaining function shall be pressure-retaining material.

(b) The requirements of this Article do not apply to material for items not associated with the pressure-retaining function of a component, such as seals, gaskets, and ceramic insulating material and special alloys used as seal material in electrical penetration assemblies.

(c) Pressure-retaining material of ferritic steel whose thickness exceeds $\frac{1}{4}$ in. (6 mm) for containment vessels shall be normalized or quenched and tempered, fully killed, and melted to a fine grain melting practice, whenever the material is not impact tested (NE-2311).

(d) Welding and brazing materials used in manufacture of items shall comply with an SFA Specification in Section II, Part C, except as otherwise permitted in Section IX, and shall also comply with the applicable requirements of this Article. The requirements of this Article do not apply to materials used as backing rings or backing strips in welded joints.

(e) The requirements of this Article do not apply to hard surfacing or corrosion resistant weld metal overlay which is 10% or less of the thickness of the base material (NE-3122).

NE-2122 Special Requirements Conflicting With Permitted Material Specifications

Special requirements stipulated in this Article shall apply in lieu of the requirements of the material specifications wherever these special requirements conflict with the material specification requirements (NCA-4256). Where the special requirements include an examination, test, or treatment which is also required by the material specification, the examination, test, or treatment need be performed only once. Required nondestructive examinations shall be performed as specified for each product form in NE-2500. Any examination, repair, test, or treatment may be performed by the Material Organization or Certificate Holder as provided in NE-4121.1. Any hydrostatic or pneumatic pressure test required by a material specification need not be performed, provided the material is identified as not having been pressure tested and it

**Table NE-2121(a)-1
Material Specifications and Grades Permitted for Class MC Construction**

<p>Carbon Steel</p> <p>Plate</p> <p>SA-36</p> <p>SA-299</p> <p>SA-516 Grade 55, 60, 65, 70</p> <p>SA-537 Class 1, 2</p> <p>SA-737 Grade B, C</p> <p>SA-738 Grade B, C [Note (1)]</p> <p>Forging</p> <p>SA-105</p> <p>SA-181 Class 60, 70</p> <p>SA-266 Class 1, 2</p> <p>SA-350 Grade LF1, LF2</p> <p>SA-508 Class 1</p> <p>SA-541 Class 1</p> <p>Casting</p> <p>SA-216 Grade WCA, WCB, WCC</p> <p>SA-352 Grade LCB</p> <p>SA-487 Grade 16 Class A</p> <p>Bar</p> <p>SA-36</p> <p>SA-695 Grade 35 Type B, Grade 40 Type B</p> <p>SA-696 Grade B, C</p> <p>Pipe, Tube, Fitting</p> <p>SA-106 Grade A, B, C</p> <p>SA-178 Grade C</p> <p>SA-210 Grade A-1</p> <p>SA-234 Grade WPB, WPBW, WPC, WPCW</p> <p>SA-333 Grade 1, 6</p> <p>SA-334 Grade 1, 6</p> <p>SA-420 Grade WPL6, WPL6W</p> <p>SA-671 Grade CC60, CC65, CC70, CD70, CD80, CE55, CE60, CK75</p> <p>SA-691 Grade CMS75, CMSH70, CMSH80</p> <p>Shape</p> <p>SA-36</p> <p>Precipitation Hardened Steels</p> <p>Plate</p> <p>SA-693 Grade 630</p> <p>Bar</p> <p>SA-564 Grade 630</p> <p>Forging</p> <p>SA-705 Grade 630</p> <p>High Alloy Type 304 Stainless Steels</p> <p>Plate</p> <p>SA-240 Type 304, 304L, 304H, 304LN</p> <p>Forging</p> <p>SA-182 Grade F304, F304L, F304H, F304LN</p> <p>SA-965 Class F304, F304LN, F304H</p>	<p>Casting</p> <p>SA-351 Grade CF3, CF8, CF3A, CF8A</p> <p>Bar</p> <p>SA-479 Type 304L, 304LN, 304</p> <p>Pipe, Tube, Fitting</p> <p>SA-213 Grade TP304L, TP304LN, TP304, TP304H</p> <p>SA-249 Grade TP304L, TP304LN, TP304, TP304H</p> <p>SA-312 Grade TP304L, TP304LN, TP304, TP304H</p> <p>SA-358 Grade 304L Class 1, 304LN Class 1, 304 Class 1, 304H Class 1</p> <p>SA-376 Grade TP304LN, TP304, TP304H</p> <p>SA-403 Class WP304L, WP304LW, WP304, WP304H, WP304W, WP304HW, WP304LN, WP304LNW</p> <p>SA-813 Grade TP304L, TP304LN, TP304, TP304H, TP304N</p> <p>SA-814 Grade TP304L, TP304LN, TP304, TP304H</p> <p>High Alloy Type 316 Stainless Steels</p> <p>Plate</p> <p>SA-240 Type 316L, 316, 316H 316LN</p> <p>Forging</p> <p>SA-182 Grade F316L, F316LN, F316, F316H</p> <p>SA-965 Class F316LN, F316, F316H</p> <p>Casting</p> <p>SA-351 Grade CF3M, CF8M</p> <p>Bar</p> <p>SA-479 Type 316L, 316, 316LN</p> <p>Pipe, Tube, Fitting</p> <p>SA-213 Grade TP316L, TP316, TP316H, TP316LN</p> <p>SA-249 Grade TP316L, TP316, TP316H, TP316LN</p> <p>SA-312 Grade TP316L, TP316, TP316H, TP316LN</p> <p>SA-358 Grade 316L Class 1, 316 Class 1, 316H Class 1, 316LN Class 1</p> <p>SA-376 Grade TP316LN, TP316, TP316H</p> <p>SA-403 Class WP316L, WP316LW, WP316LN, WP316LNW, WP316, WP316W, WP316H, WP316HW</p> <p>SA-813 Grade TP316L, TP316, TP316H, TP316LN</p> <p>SA-814 Grade TP316L, TP316, TP316H, TP316LN, TP316N</p> <p>High Alloy Type 309, 310 Stainless Steels</p> <p>Casting</p> <p>SA-351 Grade CH8, CK20, CH20</p> <p>High Alloy Type 321 Steels</p> <p>Plate</p> <p>SA-240 Type 321</p> <p>Forging</p> <p>SA-182 Grade F321, F321H</p> <p>SA-965 Class F321, F321H</p> <p>Bar</p> <p>SA-479 Grade 321</p> <p>Pipe, Tube, Fitting</p> <p>SA-213 Grade TP321, TP321H</p> <p>SA-249 Grade TP321, TP321H</p> <p>SA-312 Grade TP321, TP321H</p>
--	--

Table NE-2121(a)-1
Material Specifications and Grades Permitted for Class MC Construction (Cont'd)

<p>Pipe, Tube, Fitting (Cont'd)</p> <p>SA-376 Grade TP321, TP321H</p> <p>SA-403 Class WP321, WP321H, WP321W, WP321HW</p> <p>SA-813 Grade TP321, TP321H</p> <p>SA-814 Grade TP321, TP321H</p> <p>High Alloy Type 347, 348 Stainless Steels</p> <p>Plate</p> <p>SA-240 Type 347, 348</p> <p>Forging</p> <p>SA-182 Grade F347, F347H, F348, F348H</p> <p>SA-965 Class F347, F347H</p> <p>Casting</p> <p>SA-351 Grade CF8C</p> <p>Bar</p> <p>SA-479 Grade 347, 348</p> <p>Pipe, Tube, Fitting</p> <p>SA-213 Grade TP347, TP347H, TP348, TP348H</p> <p>SA-249 Grade TP347, TP347H, TP348, TP348H</p> <p>SA-312 Grade TP347, TP347H, TP348, TP348H</p> <p>SA-376 Grade TP347, TP347H, TP348</p> <p>SA-403 Class WP347, WP347H, WP347W, WP347HW, WP348, WP348H, WP348W, WP348HW</p> <p>SA-813 Grade TP347, TP347H, TP348H</p> <p>SA-814 Grade TP347, TP347H, TP348, TP348H</p> <p>Type XM-19 Stainless Steels</p> <p>Plate</p> <p>SA-240 Type XM-19</p> <p>Forging</p> <p>SA-182 Grade FXM-19</p> <p>Bar</p> <p>SA-479 Type XM-19</p>	<p>Pipe, Tube, Fitting</p> <p>SA-249 Grade TPXM-19</p> <p>SA-312 Grade TPXM-19</p> <p>SA-358 Grade XM-19</p> <p>SA-403 Class WPXM-19, WPXM-19W</p> <p>SA-813 Grade TPXM-19</p> <p>SA-814 Grade TPXM-19</p> <p>High Nickel Alloys</p> <p>Plate</p> <p>SB-168 Grade N06600</p> <p>SB-409 Grade 800, 800H</p> <p>SB-443 Grade N06625</p> <p>Bar</p> <p>SB-166 Grade N06600</p> <p>SB-408 Grade 800, 800H</p> <p>Pipe, Tube, Fitting</p> <p>SB-163 Grade N06600, 800, 800H</p> <p>SB-167 Grade N06600</p> <p>SB-407 Grade 800, 800H</p> <p>Nickel-Copper Alloys</p> <p>Plate</p> <p>SB-127 Grade 400</p> <p>Bar</p> <p>SB-164 Grade 400, 405</p> <p>Pipe, Tube, Fitting</p> <p>SB-163 Grade 400</p> <p>SB-165 Grade 400</p>
---	--

NOTE: (1) SA-20 Supplementary Requirements S1 "Vacuum Treatment" and S20 "Maximum Carbon Equivalent for Weldability" shall be mandatory for this material.

Table NE-2121(a)-2
Permitted Bolting Material
Specifications

<p>Low Alloy Steels</p> <p>SA-193 Grade B7, B16</p> <p>SA-320 Grade L43</p> <p>High Alloy Steels</p> <p>SA-193 Grade B6 Class 410</p> <p>SA-193 Grade B8, B8C, B8T, B8M</p> <p>SA-437 Grade B4B, B4C</p> <p>SA-453 Grade 651, 660</p>

is subsequently pressure tested, except where the location of the material in the vessel or the installation would prevent performing any nondestructive examination required by the material specification to be performed subsequent to the hydrostatic or pneumatic test.

(a) The stress rupture test of SA-453 and SA-638 for Grade 660 (UNS S66286) is not required for design temperatures of 800°F (427°C) and below.

(b) In addition to tension testing required by the material specification, forgings produced for flat heads and tubesheets with integrally forged hubs, for butt welding to the adjacent shell, head, or other pressure part, shall have tensile tests performed in accordance with NE-4243.1. The tension test specimen shall be located in accordance with NE-4243.1 and Figure NE-4243.1-1.

NE-2124 Material Size Ranges and Tolerances

(a) Material outside the limits of size or thickness given in any specification in Section II may be used if the material is in compliance with the other requirements of the specification and no size limitation is given in this Subsection. In those specifications in which chemical composition or mechanical properties are indicated to vary with size or thickness, any material outside the specification range shall be required to conform to the composition and mechanical properties shown for the nearest specified range (NCA-4256).

(b) Plate material shall be ordered not thinner than the design thickness. Vessels, except for piping, made of plate furnished with an undertolerance of not more than the lesser value of 0.01 in. (0.3 mm) or 6% of the ordered thickness may be used at the full design pressure for the thickness ordered. If the specification to which the plate is ordered allows a greater undertolerance, the ordered thickness of the material shall be sufficiently greater than the design thickness so that the thickness of the material furnished is not more than the lesser of 0.01 in. (0.3 mm) or 6% under the design thickness.

(c) If pipe or tube is ordered by its nominal wall thickness, the manufacturing undertolerance on wall thickness shall be taken into account. The manufacturing undertolerances are given in the several pipe and tube specifications listed in [Table NE-2121\(a\)-1](#). After the minimum wall thickness is determined, it shall be increased by an amount sufficient to provide for the manufacturing undertolerance allowed in the pipe or tube specification.

NE-2125 Materials in Combination¹

A vessel may be designed and constructed of any combination of materials permitted in [Article NE-2000](#), provided the applicable rules are followed and the requirements of Section IX for welding dissimilar metals are met.

NE-2126 Condition of Material for Intended Service

Specific chemical compositions, heat treatment procedures, fabrication requirements, and supplementary tests may be required to ensure that the component will be in its most favorable condition for the intended service. This is particularly true for components subject to severe corrosion. These rules do not indicate the selection of material suitable for the intended service or the amount of corrosion allowance to be provided. It is recommended that Owners assure themselves, by appropriate tests or other means, that the material selected and its heat treatment during fabrication will be suitable for the intended service with respect both to corrosion resistance and to retention of satisfactory mechanical properties during the desired service life.

NE-2127 Clad Plate

(a) Clad plate used in constructions in which the design calculations are based on the total thickness, including cladding, shall conform to one of the following specifications:

(1) SA-263 Corrosion-Resisting Chromium Steel Clad Plate, Sheet, and Strip;

(2) SA-264 Stainless Chromium-Nickel Steel Clad Plate, Sheet, and Strip;

(3) SA-265 Nickel and Nickel-Base Alloy Clad Steel Plate.

(b) Clad plate used in constructions in which the design calculations are based on the clad plate thickness, exclusive of the thickness of the cladding material, may consist of any base plate material satisfying the requirements of [NE-2121](#) and any metallic cladding material of weldable quality that in the judgment of the Owner is suitable for the intended service.

(c) Integrally clad steel plate in which any part of the cladding is included in the design calculations, as permitted in [NE-3122.4\(b\)](#), shall show a minimum shear strength of 20.0 ksi (138 MPa) when tested in the manner described in the plate specification. One shear test shall be made on each such clad plate as rolled and the results shall be reported by the mill.

(d) When any part of the cladding thickness is specified as an allowance for corrosion, such added thickness shall be removed before mill tension tests are made. When corrosion of the cladding is not expected, no part of the cladding material need be removed before testing, even though excess thickness seems to have been provided or is available as corrosion allowance.

NE-2128 Bolting Material

(a) Material for nuts shall conform to SA-194 or to the requirements for nuts in the specification for the bolting material which is to be used.

(b) Nuts shall be threaded to Class 2B or finer tolerances according to ASME B1.1. Materials for nuts and washers shall be selected as follows.

(1) Carbon steel nuts and carbon steel washers may be used with carbon steel bolts or studs.

(2) Carbon or alloy steel nuts and carbon or alloy steel washers of approximately the same hardness as the nuts may be used with alloy steel bolts or studs for metal temperatures not exceeding 900°F (480°C).

(3) Alloy steel nuts shall be used with alloy steel studs or bolts for metal temperatures exceeding 900°F (480°C). Washers, if used, shall be of alloy steel with equivalent chemistry and hardness to the nut material.

(c) Nuts shall be semifinished, chamfered, and trimmed. For use with flanges conforming to the standards listed in [NE-3362](#), nuts shall conform at least to the dimensions given in ASME/ANSI B18.2.2 for Heavy Series Nuts. For use with connections designed in

accordance with the rules in Section III Appendices, Mandatory Appendix XI, nuts may be of the Heavy Series or they may be of other dimensions, provided their strength is equal to that of the bolting, giving due consideration to bolt hole clearance, bearing area, thread form and class of fit, thread shear, and radial thrust from threads.

NE-2130 CERTIFICATION OF MATERIAL

All material used in the construction of Class MC containment vessels shall be certified as required in NCA-3862 and NCA-3861. Certified Material Test Reports are required for pressure-retaining material except as provided by NCA-3861. A Certificate of Compliance may be provided in lieu of Certified Material Test Reports for all other material. Copies of all Certified Material Test Reports and Certificates of Compliance applicable to material used in a vessel shall be furnished with the material.

NE-2140 WELDING MATERIAL

For the requirements governing the material to be used for welding, see [NE-2400](#).

NE-2150 MATERIAL IDENTIFICATION

The identification of pressure-retaining material shall meet the requirements of NCA-4256. Material for small items shall be controlled during manufacture of the vessel so that they are identifiable as acceptable material at all times. Welding and brazing material shall be controlled during the repair of material and the manufacture of vessels so that they are identifiable as acceptable until the material is actually consumed in the process ([NE-4122](#)).

(21) NE-2160 DETERIORATION OF MATERIAL IN SERVICE

Consideration of deterioration of material caused by service is generally outside the scope of this Subsection. It is the responsibility of the Owner to select material suitable for the conditions stated in the Design Specifications (NCA-3211.19), with specific attention being given to the effects of service conditions upon the properties of the material.

NE-2170 HEAT TREATMENT TO ENHANCE IMPACT PROPERTIES

Carbon steels, low alloy steels, and high alloy chromium (Series 4XX) steels may be heat treated by quenching and tempering to enhance their impact properties. Postweld heat treatment of the material at a temperature of not less than 1,100°F (595°C) may be considered to be the tempering phase of the heat treatment. The requirements of [NE-2220](#) shall be met.

NE-2180 PROCEDURES FOR HEAT TREATMENT OF MATERIAL

When heat treating temperature or time is required by the material specification and the rules of this Subsection, the heat treating shall be performed in temperature-surveyed and -calibrated furnaces or the heat treating shall be controlled by measurement of material temperature by thermocouples in contact with the material or attached to blocks in contact with the material, or by calibrated pyrometric instruments. Heat treating shall be performed under furnace loading conditions such that the heat treatment is in accordance with the material specification and the rules of this Subsection.

NE-2190 NON-PRESSURE-RETAINING MATERIAL

(a) Material in the containment vessel support load path and not performing a pressure-retaining function (see [NE-1130](#)) welded to pressure-retaining material shall meet the requirements of Article NF-2000.

(b) Material not performing a pressure-retaining function and not in the containment vessel support load path (nonstructural attachments) welded at or within $2t$ of the pressure-retaining portion of the vessel need not comply with [Article NE-2000](#) or Article NF-2000, provided the requirements of [NE-4430](#) are met.

(c) Structural steel rolled shapes, which are permitted by this Subsection to be furnished with a Certificate of Compliance, may be repaired by welding using the welders, documentation, and examination requirements specified in SA-6.

NE-2200 MATERIAL TEST COUPONS AND SPECIMENS FOR FERRITIC STEEL MATERIAL

NE-2210 HEAT TREATMENT REQUIREMENTS

NE-2211 Test Coupon Heat Treatment for Ferritic Material²

Where ferritic steel material is subjected to heat treatment during fabrication or installation of a containment vessel, the material used for the tensile and impact test specimens shall be heat treated in the same manner as the containment vessel, except that test coupons and specimens for P-No. 1, Group Nos. 1 and 2, material with a nominal thickness of 2 in. (50 mm) or less are not required to be so heat treated. The Certificate Holder shall provide the Material Organization with the temperature and heating and cooling rate to be used. In the case of postweld heat treatment, the total time at temperature or temperatures for the test material shall be at least 80% of the total time at temperature or temperatures during actual postweld heat treatment of the material, and the total time at

temperature or temperatures for the test material, coupon, or specimen may be performed in a single cycle.

NE-2212 Test Coupon Heat Treatment for Quenched and Tempered Material

NE-2212.1 Cooling Rates. Where ferritic steel material is subjected to quenching from the austenitizing temperature, the test coupons representing those materials shall be cooled at a rate similar to and no faster than the main body of the material, except in the case of certain forgings and castings [NE-2223.3 and NE-2226(b)(5)]. This rule shall apply for coupons taken directly from the material as well as for separate test coupons representing the material, and one of the general procedures described in NE-2212.2 or one of the specific procedures described in NE-2220 shall be used for each product form.

NE-2212.2 General Procedures. One of the general procedures in (a), (b), and (c) below may be applied to quenched and tempered material or test coupons representing the material, provided the specimens are taken relative to the surface of the product in accordance with NE-2220. Further specific details of the methods to be used shall be the obligation of the Material Organization and the Certificate Holder.

(a) Any procedure may be used which can be demonstrated to produce a cooling rate in the test material that matches the cooling rate of the main body of the product at the region midway between midthickness and the surface ($\frac{1}{4}t$) and no nearer any heat-treated edge than a distance equal to the nominal thickness t being quenched within 25°F (14°C) and 20 sec at all temperatures after cooling begins from the austenitizing temperature.

(b) If cooling rate data for the material and cooling rate control devices for the test specimens are available, the test specimens may be heat treated in the device to represent the material, provided that the provisions of (a) above are met.

(c) When any of the specific procedures described in NE-2220 are used, faster cooling rates at the edges may be compensated for by:

(1) taking the test specimens at least t from a quenched edge, where t equals the material thickness;

(2) attaching a steel pad at least t wide by a partial penetration weld (which completely seals the buffered surface) to the edge where specimens are to be removed; or

(3) using thermal barriers or insulation at the edge where specimens are to be removed.

It shall be demonstrated (and this information shall be included in the Certified Material Test Report) that the cooling rates are equivalent to (a) or (b) above.

NE-2220 PROCEDURE FOR OBTAINING TEST COUPONS AND SPECIMENS FOR QUENCHED AND TEMPERED MATERIAL

NE-2221 General Requirements

The procedure for obtaining test specimens for quenched and tempered material is related to the product form. Coupon and specimen location shall be as required by the material specification, except as stated in the following paragraphs of this subarticle. References to dimensions signify nominal values.

NE-2222 Plates

NE-2222.1 Orientation and Location of Coupons.

Coupons shall be taken so that specimens shall have their longitudinal axes at least $\frac{1}{4}t$ from a rolled surface and with the midlength of the specimen at least t from any heat-treated edge, where t is the nominal thickness of the material.

NE-2222.2 Requirements for Separate Test Coupons.

Where a separate test coupon is used to represent the component material, it shall be of sufficient size to ensure that the cooling rate of the region from which the test coupons are removed represents the cooling rate of the material at least $\frac{1}{4}t$ deep and t from any edge of the product. Unless cooling rates applicable to the bulk pieces or product are simulated in accordance with NE-2212.2, the dimensions of the coupon shall be not less than $3t \times 3t \times t$, where t is the nominal material thickness.

NE-2223 Forgings

NE-2223.1 Location of Coupons. Coupons shall be taken so that specimens shall have their longitudinal axes at least $\frac{1}{4}t$ from any surface and with the midlength of the specimens at least t from any second surface, where t is the maximum heat-treated thickness. A thermal buffer as described in NE-2212.2(c) may be used to achieve these conditions, unless cooling rates applicable to the bulk forgings are simulated as otherwise provided in NE-2212.2.

NE-2223.2 Very Thick and Complex Forgings. Test coupons for forgings which are both very thick and complex, such as contour nozzles, thick tubesheets, flanges, nozzles, and other complex forgings that are contour shaped or machined to essentially the finished product configuration prior to heat treatment, may be removed from prolongations or other stock provided on the product. The Certificate Holder shall specify the surfaces of the finished product subjected to high tensile stresses in service. The coupons shall be taken so that specimens shall have their longitudinal axes at a distance below the nearest heat-treated surface, equivalent to at least the greatest distance that the indicated high

tensile stress surface will be from the nearest surface during heat treatment, and with the midlength of the specimens a minimum of twice this distance from a second heat-treated surface. In any case, the longitudinal axes of the specimens shall not be nearer than $\frac{3}{4}$ in. (19 mm) to any heat-treated surface and the midlength of the specimens shall be at least $1\frac{1}{2}$ in. (38 mm) from any heat-treated surface.

NE-2223.3 Coupons From Separately Produced Test Forgings. Test coupons representing forgings from one heat and one heat treatment lot may be taken from a separately forged piece under the conditions given in (a) through (e) below.

(a) The separate test forging shall be of the same heat of material and shall be subjected to substantially the same reduction and working as the production forging it represents.

(b) The separate test forging shall be heat treated in the same furnace charge and under the same conditions as the production forging.

(c) The separate test forging shall be of the same nominal thickness as the production forging.

(d) Test coupons for simple forgings shall be taken so that specimens shall have their longitudinal axes at the region midway between midthickness and the surface and with the midlength of the specimens no nearer any heat-treated edge than a distance equal to the forging thickness, except when the thickness-length ratio of the production forging does not permit, in which case a production forging shall be used as the test forging and the midlength of the specimens shall be at the midlength of the test forging.

(e) Test coupons for complex forgings shall be taken in accordance with NE-2223.2.

NE-2223.4 Test Specimens for Forgings. When test specimens for forgings are to be taken under the applicable specification, the Inspector shall have the option of witnessing the selection, placing an identifying stamp on them, and witnessing the testing of these specimens.

NE-2224 Location of Coupons

(a) *Bars.* Coupons shall be taken so that specimens shall have their longitudinal axes at least $\frac{1}{4}t$ from the outside or rolled surface, and with the midlength of the specimens at least t from a heat-treated end where t is either the bar diameter or thickness.

(b) *Bolting Material.* For bolting material, the coupons shall be taken in conformance with the applicable material specification and with the midlength of the specimen at least one diameter or thickness from a heat-treated end. When the studs, nuts, or bolts are not of sufficient length, the midlength of the specimen shall be at the midlength of the studs, nuts, or bolts. The studs, nuts, or bolts selected to provide test coupon material shall be identical with

respect to the quenched contour and size except for length, which shall equal or exceed the length of the represented studs, nuts, or bolts.

NE-2225 Tubular Products and Fittings

NE-2225.1 Location of Coupons. Coupons shall be taken so that specimens shall have their longitudinal axes at least $\frac{1}{4}t$ from the inside or outside surface and with the midlength of the specimens at least t from a heat-treated end where t is the nominal wall thickness of the tubular product.

NE-2225.2 Separately Produced Coupons Representing Fittings. Separately produced test coupons representing fittings may be used. When separately produced coupons are used, the requirements of NE-2223.3 shall be met.

NE-2226 Tensile Test Specimen Location (for Quenched and Tempered Ferritic Steel Castings)

NOTE: Users of this requirement should note that the hardenability of some grades may limit the usable section size.

(a) This section applies only to quenched and tempered ferritic steel castings with a thickness t exceeding 2 in. (50 mm), where t is the thickness of the pressure-retaining wall of the casting, excluding flanges and sections designated by the designer as nonpressure retaining. The order, inquiry, and drawing shall designate what the thickness t is for the casting.

(b) One of the following shall apply.

(1) The longitudinal centering of the thickness of the tension test specimen shall be taken at least $\frac{1}{4}t$ from the t dimension surface. For cylindrical castings, the longitudinal center line of the specimens shall be taken at least $\frac{1}{4}t$ from the outside or inside surface and the gage length at least t from the as-heat-treated end.

(2) Where separately cast test coupons are used, their dimensions shall be not less than $3t \times 3t \times t$ and each specimen cut from it shall meet the requirements of (b). The test coupon shall be of the same heat of steel and shall receive substantially the same casting practices as the production casting it represents. (Centrifugal castings may be represented by statically cast coupons.) The test coupon shall be heat treated under the same conditions as the production casting(s). The t dimension of the test coupon shall be the same maximum thickness t as defined in (a) above. Where separate test blocks require reheat treatment, thermal buffers in accordance with (b) may be used.

(3) Where specimens are to be removed from the body of the casting, a steel, thermal buffer pad $1t \times 1t \times$ at least $3t$ shall be joined to the casting surface by a partial penetration weld completely sealing the buffered surface prior to the heat treatment process. The test specimens shall be removed from the

casting in a location adjacent to the center third of the buffer pad. They shall be located at a minimum distance of 1/2 in. (13 mm) from the buffered surface and 1/4t from the other heat-treated surfaces.

(4) Where specimens are to be removed from the body of the casting, thermal insulation or other thermal barriers shall be used during the heat treatment process adjacent to the casting edge where specimens are to be removed. It shall be demonstrated that the cooling rate of the test specimen is no faster than that of specimens taken by the method described in (1) above. This information shall be included in the test reports.

(5) Where castings are cast or machined to essentially the finished product configuration prior to heat treatment, the test specimens shall be removed from a casting prolongation or other stock on the product at a location below the nearest heat-treated surface indicated on the order. The specimens shall be located with their longitudinal axes a distance below the nearest heat-treated surface equivalent to at least the greatest distance that the indicated high tensile stress surface will be from the nearest heat-treated surface and with their midlength a minimum of twice this distance from a second heat-treated surface. In any case, the longitudinal axes of the test specimens shall be no nearer than 1/4 in. (6 mm) to a heat-treated surface and the midlength shall be at least 1 1/2 in. (38 mm) from a second heat-treated surface. The component manufacturer shall specify the surfaces of the finished product subjected to high tensile stress in service.

NE-2300 FRACTURE TOUGHNESS REQUIREMENTS FOR MATERIAL

NE-2310 MATERIAL TO BE IMPACT TESTED

NE-2311 Material for Which Impact Testing Is Required

(a) Pressure-retaining material shall be impact tested in accordance with the requirements of NE-2330, except that impact testing of materials described in (1) through (9) below is not a requirement of this Subsection, provided the requirements of NE-2121(c) are met.

(1) material with a nominal section thickness of 5/8 in. (16 mm) or less where the thickness shall be taken as defined in (-a) through (-d) below:

(-a) for vessels, use the nominal thickness of the shell or head, as applicable;

(-b) for nozzles or parts welded to vessels, use the lesser of the vessel shell thickness to which the item is welded or the maximum radial thickness of the item exclusive of integral shell butt welding projections;

(-c) for flat heads, tubesheets, or flanges, use the maximum shell thickness associated with the butt welding hub;

(-d) for integral fittings used to attach process piping to the containment vessel (Figure NE-1110-1), use the larger nominal thickness of the pipe connections;

(2) bolting, including studs, nuts, and bolts of NPS 1 in. (25 mm) or less;

(3) bars with a nominal cross-sectional area which does not exceed 1 in.² (650 mm²);

(4) all thicknesses of material for pipe, tube, and fittings of NPS 6 in. diameter (DN 150) and smaller;

(5) material for fittings with pipe connections of 5/8 in. (16 mm) nominal wall thickness and less;

(6) austenitic stainless steels, including precipitation hardened austenitic Grade 660 (UNS S66286);

(7) nonferrous materials;

(8) materials listed in Table NE-2311(a)-1 for which the listed value of T_{NDT}³ is lower than the Lowest Service Metal Temperature⁴ (LST) by an amount established by the rules in Section III Appendices, Nonmandatory Appendix R. This exemption does not exempt either the weld metal (NE-2430) or the welding procedure qualification (NE-4335) from impact testing.

(9) materials for components for which the Lowest Service Temperature exceeds 150°F (65°C);

(b) The Design Specification shall state the Lowest Service Temperature for the component.

(c) Drop weight tests are not required for the martensitic high alloy chromium (Series 4XX) steels and precipitation-hardening steels listed in Section II, Part D, Subpart 1, Table 1A. The other requirements of

Table NE-2311(a)-1 Exemptions From Impact Testing Under NE-2311(a)(8)

Material [Note (1)]	Material Condition [Note (2)]	T _{NDT} , °F (°C) [Notes (3), (4)]
SA-537 Class 1	N	-30 (-34)
SA-516 Grade 70	Q&T	-10 (-23)
SA-516 Grade 70	N	0 (-18)
SA-508 Class 1	Q&T	+10 (-12)
SA-299 [Note (5)]	N	+20 (-7)
SA-216 Grades WCB, WCC	Q&T	+30 (-1)

NOTES:

(1) These materials are exempt from toughness testing when LST - T_{NDT} is satisfied in accordance with the rules established in Section III Appendices, Nonmandatory Appendix R.

(2) Material Condition letters refer to:

N = Normalize

Q&T = Quench and Temper

(3) These values for T_{NDT} were established from data on heavy section steel [thickness greater than 2 1/2 in. (64 mm)]. Values for sections less than 2 1/2 in. (64 mm) thick are held constant until additional data are obtained.

(4) T_{NDT}: Temperature at or above nil-ductility transition temperature NDT (ASTM E208); T_{NDT} is 10°F (5.6°C) below the temperature at which at least two specimens show no-break performance.

(5) Materials made to a fine grain melting practice.

NE-2331 and NE-2332 apply for these steels. For nominal wall thicknesses greater than $2\frac{1}{2}$ in. (64 mm), the required C_v values shall be 40 mils (1.0 mm) lateral expansion.

NE-2320 IMPACT TEST PROCEDURES

NE-2321 Types of Tests

NE-2321.1 Drop Weight Tests. The drop weight test, when required, shall be performed in accordance with ASTM E208. Specimen type P-1, P-2, or P-3 may be used. When drop weight tests are performed to meet the requirements of NE-2300, the test temperature and the results shall be reported on the Certified Material Test Report.

NE-2321.2 Charpy V-Notch Tests. The Charpy V-notch tests (C_v), when required, shall be performed in accordance with SA-370. Specimens shall be in accordance with SA-370, Figure 11, Type A. A test shall consist of a set of three full-size 10 mm × 10 mm specimens. The lateral expansion and absorbed energy, as applicable, and the test temperature, as well as the orientation and location of all tests performed to meet the requirements of NE-2330 shall be reported in the Certified Material Test Report.

NE-2322 Test Specimens

NE-2322.1 Location of Test Specimens. Impact test specimens shall be removed from a depth within the material that is at least as far from the material surface as that specified for tensile test specimens in the material specification. For bolting, the C_v impact test specimens shall be taken with the longitudinal axis of the specimen located at least one-half radius or 1 in. (25 mm) below the surface plus the machining allowance per side, whichever is less. The fracture plane of the specimen shall be at least one diameter or thickness from the heat-treated end. When the studs, nuts, or bolts are not of sufficient length, the midlength of the specimen shall be at the midlength of the studs, nuts, or bolts. The studs, nuts, or bolts selected to provide test coupon material shall be identical with respect to the quenched contour and size except for length, which shall equal or exceed the length of the represented studs, nuts, or bolts.

NE-2322.2 Orientation of Test Specimens.

(a) Specimens for C_v impact tests for quenched and tempered material shall be oriented in accordance with the requirements of NE-2220 and for other material in accordance with the requirements given in SA-370.

(b) Specimens for drop weight tests may have their axes oriented in any direction.

NE-2330 TEST REQUIREMENTS AND ACCEPTANCE STANDARDS

NE-2331 Pressure-Retaining Material Test Methods and Temperature

(a) Pressure-retaining material shall be impact tested in accordance with one of the test methods indicated below.

(1) Charpy V-notch testing at or below the Lowest Service Metal Temperature.^{4, 5}

(2) Drop weight testing to show that the Lowest Service Metal Temperature⁴ ($LST - T_{NDT}$) is satisfied in accordance with the rules established in Section III Appendices, Nonmandatory Appendix R.

(b) In addition, when the Design Specification requires a vessel hydrostatic or pneumatic test temperature which is lower than the Lowest Service Metal Temperature,⁴ the impact testing for pressure-retaining material shall be performed in accordance with (a) above, at or below the lowest specified vessel test temperature. As an alternative, a Lowest Overpressure Test Metal Temperature⁶ shall be specified. In this case, Charpy V-notch testing, in addition to the tests required by (a) above, shall be performed as specified in NE-2321.2 at a temperature 30°F (17°C) or more below the Lowest Overpressure Test Metal Temperature in accordance with NE-2333.

(c) The use of the material below the temperature established by the methods of (a) or (b) above may be justified by methods equivalent to those contained in Section III Appendices, Nonmandatory Appendix G.

NE-2332 Specific Test Methods and Acceptance Standards for Pressure-Retaining Material for Tests Based on Lowest Service Metal Temperatures

NE-2332.1 Pressure-Retaining Material Other Than Bolting With $2\frac{1}{2}$ in. (64 mm) Maximum Thickness. Except as limited in NE-4335, apply one of the methods of NE-2331(a) to test: the base material; the base material, the heat-affected zone, and the weld metal for the weld procedure qualification tests of NE-4335; and the weld metal for NE-2431.

The impact test results shall meet one of the acceptance standards applicable to the specified test method.

(a) *Charpy V-Notch Testing for Lateral Expansion Values.* The test results of the three specimens, collectively and singly, shall meet the respective requirements of Table NE-2332.1-1.

(b) *Charpy V-Notch Testing for Absorbed Energy Values.* The test results of the three specimens, collectively and singly, shall meet the respective requirements of Table NE-2332.1-2.

Table NE-2332.1-1
Required C_v Lateral Expansion Values for Pressure-Retaining Material Other Than Bolting

Nominal Wall Thickness, in. (mm)	Lateral Expansion, mils (mm) [Notes (1), (2)]	
	Average of 3	Lowest 1 of 3
$\frac{5}{8}$ (16) or less [Note (3)]
Over $\frac{5}{8}$ to 1 (16 to 25), incl.	20 (0.50)	15 (0.38)
Over 1 to $1\frac{1}{2}$ (25 to 38), incl.	25 (0.64)	20 (0.50)
Over $1\frac{1}{2}$ to $2\frac{1}{2}$ (38 to 64), incl.	35 (0.89)	30 (0.75)
Over $2\frac{1}{2}$ (64) [Note (4)]	45 (1.1)	40 (1.0)

NOTES:

- (1) Where weld metal tests of NE-2400 are made to these requirements, the impact lateral expansion shall conform to the requirements of either of the base materials being joined.
- (2) Where two base materials having different required lateral expansion values are joined, the weld metal lateral expansion requirements of NE-4330 shall conform to the requirements of either of the base materials.
- (3) No test required.
- (4) For use with NE-2332.2(b).

(c) *Drop Weight Testing.* An acceptance test shall consist of at least two no-break specimens as described in ASTM E208.

NE-2332.2 Pressure-Retaining Material Other Than Bolting With Thickness Exceeding $2\frac{1}{2}$ in. (64 mm).

(a) The base material and the weld procedure qualification weld metal tests of NE-4335 shall be tested by the drop weight method as specified in NE-2321.1 and NE-2331(a)(2).

(b) Except as limited in NE-4335, apply one of the methods of NE-2331(a) to test the base material and the heat-affected zone of the weld procedure qualification tests for NE-4335 and the weld metal for NE-2431.

(c) The acceptance standards shall be as given in NE-2332.1(a), NE-2332.1(b), or NE-2332.1(c), as applicable.

NE-2332.3 Bolting Material. The drop weight test is not applicable to bolting materials. For bolting material, including nuts, studs, and bolts, a Charpy V-notch test shall be performed. Optionally, the test may be performed at the Lowest Service Metal Temperature, or at a temperature 30°F (17°C) or more below the Lowest Service Metal Temperature.

(a) When tested at the Lowest Service Metal Temperature, lateral expansion and absorbed energy values shall be determined, and all three specimens shall meet the requirements of Table NE-2332.3(a)-1.

(b) When tested at 30°F (17°C) or more below the Lowest Service Metal Temperature, lateral expansion and absorbed energy values shall be determined, and

all three specimens shall meet the requirements of Table NE-2332.3(b)-1.

NE-2333 Specific Test Methods and Acceptance Standards for Pressure-Retaining Material for Tests Based on Lowest Overpressure Test Metal Temperature

NE-2333.1 Pressure-Retaining Material Other Than Bolting. Apply the method of NE-2331(a)(1) to test: the base material; the base material, the heat-affected zone, and the weld metal for the weld procedure qualification tests of NE-4335; and the weld metal for NE-2431.

The impact test results of the three specimens, collectively and singly, shall meet the respective requirements of Table NE-2333.1-1.

NE-2333.2 Bolting Material. For bolting material, including nuts, studs, and bolts, a Charpy V-notch test shall be performed. The test shall be performed at or below the Lowest Service Metal Temperature, and all three specimens shall meet the requirements of Table NE-2332.3(a)-1.

NE-2340 NUMBER OF IMPACT TESTS REQUIRED

NE-2341 Plates

One test shall be made from each plate as heat treated. Where plates are furnished in the nonheat-treated condition and qualified by heat-treated test specimens, one test shall be made for each plate as-rolled. The term as-rolled refers to the plate rolled from a slab or directly from an ingot, not to its heat-treated condition.

NE-2342 Forgings and Castings

(a) Where the weight of an individual forging or casting is less than 1,000 lb (450 kg), one test shall be made to represent each heat in each heat treatment lot.

(b) When heat treatment is performed in a continuous type furnace with suitable temperature controls and equipped with recording pyrometers so that complete heat treatment records are available, a heat treatment charge shall be considered as the lesser of a continuous run not exceeding 8 hr duration or a total weight, so treated, not exceeding 2,000 lb (900 kg).

(c) One test shall be made for each forging or casting of 1,000 lb to 10,000 lb (450 kg to 4 500 kg) in weight.

(d) As an alternative to (c), a separate test forging or casting may be used to represent forgings or castings of different sizes in one heat and heat treat lot, provided the test piece is a representation of the greatest thickness in the heat treat lot. In addition, test forgings shall have been subjected to substantially the same reduction and working as the forgings represented.

(e) Forgings or castings larger than 10,000 lb (4 500 kg) shall have two tests per part for Charpy V-notch, and one test for drop weights. The location of drop weight or C_v

Table NE-2332.1-2
Required C_v Energy Values for Pressure-Retaining Material Other Than Bolting

Nominal Wall Thickness, in. (mm)	Energy, ft-lb (J) for Base Materials [Note (1)] of Specified Minimum Yield Strength, ksi (MPa)					
	55 ksi (380 MPa) or Below		Over 55 ksi to 75 ksi (380 MPa to 520 MPa), Incl.		Over 75 ksi to 105 ksi (520 MPa to 724 MPa), Incl.	
	Average of 3	Lowest 1 of 3	Average of 3	Lowest 1 of 3	Average of 3	Lowest 1 of 3
⁵ / ₈ (16) or less [Note (2)]
Over ⁵ / ₈ to 1 (16 to 25), incl.	20 (27)	15 (20)	25 (34)	20 (27)	30 (41)	25 (34)
Over 1 to 1½ (25 to 38), incl.	25 (34)	20 (27)	30 (41)	25 (34)	35 (47)	30 (41)
Over 1½ to 2½ (38 to 64), incl.	35 (47)	30 (41)	40 (54)	35 (47)	45 (61)	40 (54)
Over 2½ (64) [Note (3)]	45 (61)	40 (54)	50 (68)	45 (61)	55 (75)	50 (68)

GENERAL NOTE: Where weld metal tests of NE-2400 are made to these requirements, the impact energy shall conform to the requirements of either of the base materials being joined.

NOTES:

- (1) Where two base materials having different required energy values are joined, the weld metal impact energy requirements of the procedure qualification tests of NE-4330 shall conform to the requirements of either of the base materials.
- (2) No test required.
- (3) For use with NE-2332.2(b).

Table NE-2332.3(a)-1
**Required C_v Values for Bolting Material Tested in
 Accordance With NE-2332.3(a)**

Nominal Diameter, in. (mm)	Lateral Expansion, mils (mm)	Absorbed Energy, ft-lb (J)
1 (25) or less	No test required	No test required
Over 1 through 4 (25 through 100)	25 (0.6)	No requirements
Over 4 (100)	25 (0.6)	45 (61)

Table NE-2332.3(b)-1
**Required C_v Values for Bolting Material Tested in
 Accordance With NE-2332.3(b)
 and NE-2333.2**

Nominal Diameter, in. (mm)	Lateral Expansion, mils (mm)	Absorbed Energy, ft-lb (J)
1 or less (25)	No test required	No test required
Over 1 through 4 (25 through 100)	15 (0.38)	30 (41)
Over 4 (100)	20 (0.50)	35 (47)

Table NE-2333.1-1
**Required C_v Energy Values for Pressure-Retaining
 Material Other Than Bolting for the Overpressure Test**

Nominal Wall Thickness, in. (mm)	Energy, ft-lb (J), for Base Materials [Notes (1), (2)] of Specified Minimum Tensile Strength, ksi (MPa)			
	60 ksi (415 MPa) or Below		Over 60 ksi (415 MPa)	
	Average of 3	Lowest 1 of 3	Average of 3	Lowest 1 of 3
⁵ / ₈ (16) or less [Note (3)]
Over ⁵ / ₈ (16)	15 (20)	10 (14)	20 (27)	15 (20)

NOTES:

- (1) Where weld metal tests of NE-2400 are made to these requirements, the impact energy shall conform to the requirements of either of the base materials being joined.
- (2) Where two base materials having different required energy values are joined, the weld metal impact energy requirements of the procedure qualification tests of NE-4330 shall conform to the requirements of either of the base materials.
- (3) No test required.

impact test specimens shall be selected so that an equal number of specimens is obtained from positions in the forging or casting 180 deg apart.

(f) As an alternative to (e) for static castings, a separately cast test coupon [NE-2226(b)(2)] may be used; one test shall be made for Charpy V-notch and one test for drop weight.

NE-2343 Bars

One test shall be made for each lot of bars with a cross-sectional area greater than 1 in.² (650 mm²) in each lot, where a lot is defined as one heat of material heat treated in one charge or as one continuous operation, not to exceed 6,000 lb (2700kg).

NE-2344 Tubular Products and Fittings

On products which are seamless or welded without filler metal, one test shall be made from each lot. On products which are welded with filler metal, one additional test with the specimens taken from the weld area shall also be made on each lot. A lot shall be defined as stated in the applicable material specification, but in no case shall a lot consist of products from more than one heat of material and of more than one diameter, with the nominal thickness of any product included not exceeding that to be impact tested by more than 1/4 in. (6 mm); such a lot shall be in a single heat treatment load or in the same continuous run in a continuous furnace controlled within a 50°F (28°C) range and equipped with recording pyrometers.

NE-2345 Bolting Material

One test shall be made for each lot of material where a lot is defined as one heat of material heat treated in one charge or as one continuous operation, not to exceed in weight the following:

Diameter, in. (mm)	Weight, lb (kg)
1 ³ / ₄ (44) and less	1,500 (680)
Over 1 ³ / ₄ to 2 ¹ / ₂ (44 to 64)	3,000 (1350)
Over 2 ¹ / ₂ to 5 (64 to 125)	6,000 (2700)
Over 5 (125)	10,000 (4500)

NE-2350 RETESTS

NE-2351 Retests for Material Other Than Bolting

(a) For Charpy V-notch tests required by NE-2330, one retest at the same temperature may be conducted, provided:

(1) the average value of the test results meets the average of three requirements specified in Table NE-2332.1-1, Table NE-2332.1-2, or Table NE-2333.1-1, as applicable;

(2) not more than one specimen per test is below the lowest one of three requirements specified in Table NE-2332.1-1, Table NE-2332.1-2, or Table NE-2333.1-1, as applicable;

(3) the specimen not meeting the requirements is not lower than 5 ft-lb (6.8 J) or 5 mils (0.14 mm) below the lowest one of three requirements specified in Table NE-2332.1-1, Table NE-2332.1-2, or Table NE-2333.1-1, as applicable.

(b) A retest consists of two additional specimens taken as near as practicable to the failed specimens. For acceptance of the retests, both specimens shall be equal to or greater than the average of three requirements specified in Table NE-2332.1-1, Table NE-2332.1-2, or Table NE-2333.1-1, as applicable.

NE-2352 Retests for Bolting Material

(a) For Charpy V-notch tests required by NE-2330, one retest at the same temperature may be conducted, provided:

(1) not more than one specimen per test is below the acceptance requirements;

(2) the specimen not meeting the acceptance requirements is not lower than 5 ft-lb (6.8 J) or 5 mils (0.13 mm) below the acceptance requirements.

(b) A retest consists of two additional specimens taken as near as practicable to the failed specimens. For acceptance of the retests, both specimens shall meet the specified acceptance requirements.

NE-2360 CALIBRATION OF INSTRUMENTS AND EQUIPMENT

Calibration of temperature instruments and C_v impact test machines used in impact testing shall be performed at the frequency specified in (a) and (b) below.

(a) Temperature instruments used to control test temperature of specimens shall be calibrated and the results recorded to meet the requirements of NCA-4258.2 at least once in each 3-month interval.

(b) C_v impact test machines shall be calibrated and the results recorded to meet the requirements of NCA-4258.2. The calibrations shall be performed using the frequency and methods outlined in ASTM E23 and employing standard specimens obtained from the National Institute of Standards and Technology, or any supplier of subcontracted calibration services accredited in accordance with the requirements of NCA-3126 and NCA-4255.3(c).

NE-2400 WELDING MATERIAL

NE-2410 GENERAL REQUIREMENTS

(a) All welding material used in the construction and repair of components or material, except welding material used for hard surfacing, shall conform to the requirements of the welding material specification or to the

requirements for other welding material as permitted in Section IX. In addition, welding material shall conform to the requirements stated in this subarticle and to the rules covering identification in [NE-2150](#).

(b) The Certificate Holder shall provide the organization performing the testing with the information listed below, as applicable:

- (1) welding process;
- (2) SFA Specification and classification;
- (3) other identification if no SFA Specification applies;
- (4) minimum tensile strength [[NE-2431.1\(e\)](#)] in the as-welded or heat-treated condition, or both [[NE-2431.1\(c\)](#)];
- (5) drop weight test for material as-welded or heat treated, or both ([NE-2332](#));
- (6) Charpy V-notch test for material as-welded, or heat treated, or both ([NE-2331](#)); the test temperature and the lateral expansion or the absorbed energy shall be provided;
- (7) the preheat and interpass temperature to be used during welding of the test coupon [[NE-2431.1\(c\)](#)];
- (8) postweld heat treatment time, temperature range, and maximum cooling rate, if the production weld will be heat treated [[NE-2431.1\(c\)](#)];
- (9) elements for which chemical analysis is required per the SFA Specification or WPS, and [NE-2432](#);
- (10) minimum delta ferrite ([NE-2433](#)).

NE-2420 REQUIRED TESTS

The required tests shall be conducted for each lot of covered, flux-cored, or fabricated electrodes; for each heat of bare electrodes, rod, or wire for use with the OFW, GMAW, GTAW, PAW, and EGW (electrode gas welding) processes (Section IX, QG-109); for each heat of consumable inserts; for each combination of heat of bare electrodes and lot of submerged arc flux; for each combination of lot of fabricated electrodes and lot of submerged arc flux; for each combination of heat of bare electrodes or lot of fabricated electrodes, and dry blend of supplementary powdered filler metal, and lot of submerged arc flux; or for each combination of heat of bare electrodes and lot of electroslag flux. The definitions in SFA-5.01 and the Lot Classes specified in (a) through (e) below shall apply.

- (a) each Lot Class C3 of covered electrodes.
- (b) each Lot Class T2 of tubular-cored electrodes and rods (flux cored or fabricated).
- (c) each Lot Class S2 of fully metallic solid welding consumables (bare electrode, rod, wire, consumable insert, or powdered filler metal).
- (d) each Lot Class S2 of fully metallic solid welding electrodes or each Lot Class T2 of tubular-cored (fabricated) electrodes and each Lot Class F2 of submerged arc or electroslag welding flux.

(e) each Lot Class S2 of fully metallic solid welding electrodes or each Lot Class T2 of tubular-cored (fabricated) electrodes and each Lot Class F2 of submerged arc or electroslag welding flux and each Lot Class S2 of supplementary powdered filler metal. The chemical analysis range of the supplemental powdered filler metal shall be the same as that of the welding electrode, and the ratio of powder to electrode used to make the test coupon shall be the maximum permitted for production welding.

In all cases, when filler metal of controlled chemical composition (as opposed to heat control) is used, each container of welding consumable shall be coded for identification and shall be traceable to the production period, the shift, the manufacturing line, and the analysis of the steel rod or strip. Carbon, manganese, silicon, and other intentionally added elements shall be identified to ensure that the material conforms to the SFA or user's material specification. The use of controlled chemical composition is only permitted for carbon and low alloy steel consumables. Tests performed on welding material in the qualification of weld procedures will satisfy the testing requirements for the lot, heat, or combination of heat and batch of welding material used, provided the tests required by [Article NE-4000](#) and this subarticle are made and the results conform to the requirements of this Article.

NE-2430 WELD METAL TESTS

NE-2431 Mechanical Properties Test

Tensile and impact tests shall be made, in accordance with this paragraph, of welding material which is used to join P-Nos. 1, 3, 4, 5, 6, 7, 9, and 11 base materials in any combination, with the exceptions listed in (a) through (d) below:

- (a) austenitic stainless steel and nonferrous welding material used to join the listed P-Numbers;
- (b) consumable inserts (backing filler material);
- (c) welding material used for GTAW root deposits with a maximum of two layers;
- (d) welding material to be used for the welding of base materials exempted from impact testing by [NE-2311\(a\)\(1\)](#) through [NE-2311\(a\)\(7\)](#) and [NE-2311\(a\)\(9\)](#) shall likewise be exempted from the impact testing required by this paragraph.

NE-2431.1 General Test Requirements. The welding test coupon shall be made in accordance with (a) through (f) below, using each process with which the weld material will be used in production welding.

(a) Test coupons shall be of sufficient size and thickness such that the test specimens required herein can be removed.

(b) The weld metal to be tested for all processes except electroslag welding shall be deposited in such a manner as to eliminate substantially the influence of the base material on the results of the tests. Weld metal to be used with

the electroslag process shall be deposited in such a manner as to conform to one of the applicable Welding Procedure Specifications (WPS) for production welding. The base material shall conform with the requirements of Section IX, QW-403.1 or Section IX, QW-403.4, as applicable.

(c) The welding of the test coupon shall be performed within the range of preheat and interpass temperatures which will be used in production welding. Coupons shall be tested in the as-welded condition, or they shall be tested in the applicable postweld heat-treated condition when the production welds are to be postweld heat treated. The postweld heat treatment holding time² shall be at least 80% of the maximum time to be applied to the weld metal in production application. The total time for postweld heat treatment of the test coupon may be applied in one heating cycle. The cooling rate from the postweld heat treatment temperature shall be of the same order as that applicable to the weld metal in the component. In addition, weld coupons for weld metal to be used with the electroslag process that are tested in the as-welded condition, or following a postweld heat treatment within the holding temperature ranges of Table NE-4622.1-1 or Table NE-4622.4(c)-1, shall have a thickness within the range of 0.5 to 1.1 times the thickness of the welds to be made in production. Electroslag weld coupons to be tested following a postweld heat treatment which will include heating the coupon to a temperature above the "Holding Temperature Range" of Table NE-4622.1-1 for the type of material being tested shall have a thickness within the range of 0.9 to 1.1 times the thickness of the welds to be made in production.

(d) The tensile specimens, and the C_v impact specimens where required, shall be located and prepared in accordance with the requirements of SFA-5.1, or the applicable SFA Specification. Drop weight impact test specimens, where required, shall be oriented so that the longitudinal axis is transverse to the weld with the notch in the weld face or in a plane parallel to the weld face. For impact specimen preparation and testing the applicable parts of NE-2321.1 and NE-2321.2 shall apply. The longitudinal axis of the specimen shall be at a minimum depth of $\frac{1}{4}t$ from a surface, where t is the thickness of the test weld.

(e) One all weld metal tensile specimen shall be tested and shall meet the specified minimum tensile strength requirements of the base material specification. Where base materials of different specifications are to be welded, the tensile strength requirements shall conform to the specified minimum tensile strength requirements of either of the base material specifications.

(f) Impact specimens of the weld metal shall be tested where impact tests are required for either of the base materials of the production weld. The weld metal shall conform to the requirements of NE-2332.1, NE-2332.2, or NE-2332.3, as applicable.

NE-2431.2 Standard Test Requirements. In lieu of the use of the General Test Requirements specified in NE-2431.1, tensile and impact tests may be made in accordance with this subparagraph where they are required for mild and low alloy steel covered electrodes. The material combinations which require weld material testing, as listed in NE-2431, shall apply for this Standard Test Requirements option. The limitations and testing under this Standard Test option shall be in accordance with (a) through (f) below.

(a) Testing to the requirements of this subparagraph shall be limited to electrode classifications included in Specification SFA-5.1 or SFA-5.5.

(b) The test assembly required by SFA-5.1 or SFA-5.5, as applicable, shall be used for test coupon preparation, except that it shall be increased in size to obtain the number of C_v specimens or the drop weight test specimens required by NE-2331, where applicable.

(c) The welding of the test coupon shall conform to the requirements of the SFA Specification for the classification of electrode being tested. Coupons shall be tested in the as-welded condition and also in the postweld heat-treated condition. The postweld heat treatment temperatures shall be in accordance with Table NE-4622.1-1 for the applicable P-Number equivalent. The time at postweld heat treatment temperature shall be 8 hr (this qualifies postweld heat treatments of 10 hr or less). Where the postweld heat treatment of the production weld exceeds 10 hr, or the PWHT temperature is other than that required above, the general test of NE-2431.1 shall be used.

(d) The tensile and C_v specimens shall be located and prepared in accordance with the requirements of SFA-5.1 or SFA-5.5, as applicable. Drop weight impact test specimens, where required, shall be located and oriented as specified in NE-2431.1(d).

(e) One all weld metal tensile specimen shall be tested and shall meet the specified minimum tensile strength requirement of the SFA Specification for the applicable electrode classification.

(f) The requirements of NE-2431.1(f) shall be applicable to the impact testing of this option.

NE-2432 Chemical Analysis Test

Chemical analysis of filler metal or weld deposits shall be made in accordance with NE-2420 and as required by NE-2432.1 and NE-2432.2.

NE-2432.1 Test Method. The chemical analysis test shall be performed in accordance with this subparagraph and Table NE-2432.1-1, and the results shall conform to NE-2432.2.

(a) A-No. 8 welding material to be used with GTAW and PAW processes and any other welding material to be used with any GTAW, PAW, or GMAW process shall have chemical analysis performed either on the filler metal or on a

Table NE-2432.1-1
Sampling of Welding Materials for Chemical Analysis

Welding Material	GTAW/PAW	GMAW	All Other Processes
A-No. 8 filler metal	Filler metal or weld deposit	Weld deposit	Weld deposit
All other filler metal	Filler metal or weld deposit	Filler metal or weld deposit	Weld deposit

weld deposit made with the filler metal in accordance with (c) or (d) below.

(b) A-No. 8 welding material to be used with other than the GTAW and PAW processes and other welding material to be used with other than the GTAW, PAW, or GMAW process shall have chemical analysis performed on a weld deposit of the material or combination of materials being certified in accordance with (c) or (d) below. The removal of chemical analysis samples shall be from an undiluted weld deposit made in accordance with (c) below. As an alternative, the deposit shall be made in accordance with (d) below for material that will be used for corrosion resistant overlay cladding. Where the Welding Procedure Specification or the welding material specification specifies percentage composition limits for analysis, it shall state that the specified limits apply for either the filler metal analysis or the undiluted weld deposit analysis or for *in situ* cladding deposit analysis in conformance with the above required certification testing.

(c) The preparation of samples for chemical analysis of undiluted weld deposits shall comply with the method given in the applicable SFA Specification. Where a weld deposit method is not provided by the SFA Specification, the sample shall be removed from a weld pad, groove, or other test weld⁷ made using the welding process that will be followed when the welding material or combination of welding materials being certified is consumed. The weld for A-No. 8 material to be used with the GMAW or EGW process shall be made using the shielding gas composition specified in the Welding Procedure Specification that will be followed when the material is consumed. The test sample for ESW shall be removed from the weld metal of the mechanical properties test coupon. Where a chemical analysis is required for a welding material which does not have a mechanical properties test requirement, a chemical analysis test coupon shall be prepared as required by NE-2431.1(c), except that heat treatment of the coupon is not required and the weld coupon thickness requirements of NE-2431.1(c) do not apply.

(d) The alternate method provided in (b) above for the preparation of samples for chemical analysis of welding material to be used for corrosion resistant overlay cladding shall require a test weld made in accordance with the essential variables of the Welding Procedure Specification

that will be followed when the welding material is consumed. The test weld shall be made in conformance with the requirements of Section IX, QW-214.1. The removal of chemical analysis samples shall conform with Section IX, QW-453, for the minimum thickness for which the Welding Procedure Specification is qualified.

NE-2432.2 Requirements for Chemical Analysis. The chemical elements to be determined, the composition requirements of the weld metal, and the recording of results of the chemical analysis shall be in accordance with (a), (b), and (c) below.

(a) Welding material of ferrous alloy A-No. 8 (Section IX, Table QW-442) shall be analyzed for the elements listed in Table NE-2432.2-1, and for any other elements specified either in the welding material specification referenced by the Welding Procedure Specification or in the Welding Procedure Specification.

(b) The chemical composition of the weld metal or filler metal shall conform to the welding material specification for elements having specified percentage composition limits. Where the Welding Procedure Specification contains a modification of the composition limits of SFA or other referenced welding material specifications, or provides limits for additional elements, these composition limits of the Welding Procedure Specification shall apply for acceptability.

(c) The results of the chemical analysis shall be reported in accordance with NCA-3862.1. Elements listed in Table NE-2432.2-1 but not specified in the welding material specification or Welding Procedure Specification shall be reported for information only.

NE-2433 Delta Ferrite Determination

A determination of delta ferrite shall be performed on A-No. 8 weld material (Section IX, Table QW-442); backing filler metal (consumable inserts); bare electrode, rod, or wire filler metal; or weld metal, except that delta ferrite determinations are not required for SFA-5.4 Type 16-8-2, or A-No. 8 weld filler metal to be used for weld metal cladding.

NE-2433.1 Method. Delta ferrite determinations of welding material, including consumable insert material, shall be made using a magnetic measuring instrument and weld deposits made in accordance with (b) below. Alternatively, the delta ferrite determinations for welding materials may be performed by the use of chemical analysis of NE-2432 in conjunction with Figure NE-2433.1-1.

Table NE-2432.2-1
Welding Material Chemical Analysis

Materials	Elements
Cr-Ni stainless materials	C, Cr, Mo, Ni, Mn, Si, Cb

Figure NE-2433.1-1
Weld Metal Delta Ferrite Content

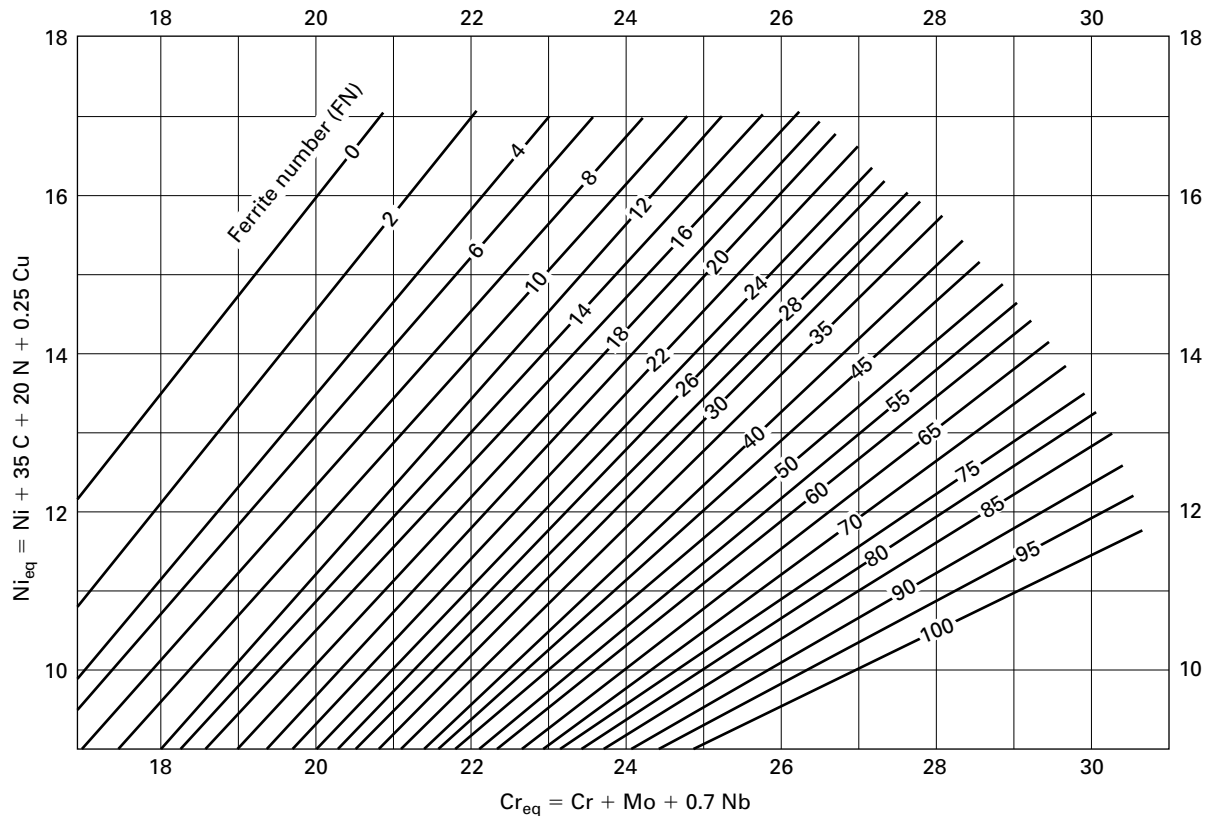

GENERAL NOTES:

- (a) The actual nitrogen content is preferred. If this is not available, the following applicable nitrogen value shall be used:
 (1) GMAW welds - 0.08%, except that when self shielding flux cored electrodes are used - 0.12%
 (2) Welds made using other processes - 0.06%.
- (b) This diagram is identical to the WRC-1992 Diagram, except that the solidification mode lines have been removed for ease of use.

(a) Calibration of magnetic instruments shall conform to AWS A4.2.

(b) The weld deposit for magnetic delta ferrite determination shall be made in accordance with NE-2432.1(c).

(c) A minimum of six ferrite readings shall be taken on the surface of the weld deposit. The readings obtained shall be averaged to a single Ferrite Number (FN).

NE-2433.2 Acceptance Standards. The minimum acceptable delta ferrite shall be 5FN. The results of the delta ferrite determination shall be included in the Certified Material Test Report of NE-2130 or NE-4120.

NE-2440 STORAGE AND HANDLING OF WELDING MATERIAL

Suitable storage and handling of electrodes, flux, and other welding materials shall be maintained. Precautions shall be taken to minimize absorption of moisture by fluxes and cored, fabricated, and coated electrodes.

NE-2500 EXAMINATION AND REPAIR OF PRESSURE-RETAINING MATERIAL

NE-2510 PRESSURE-RETAINING MATERIAL

Pressure-retaining material shall be examined and repaired in accordance with the material specification and as otherwise required by this subarticle.

NE-2530 EXAMINATION AND REPAIR OF PLATE

NE-2531 Required Examination

Plates shall be examined in accordance with the requirements of the material specification.

NE-2537 Time of Examination

Acceptance examinations shall be performed at the time of manufacture as required in (a), (b), and (c) below.

(a) Examinations required by the material specification shall be performed at the time of manufacture as specified in the material specification.

(b) Radiographic examination of repair welds, when required, may be performed prior to any required post-weld heat treatment.

(c) Magnetic particle or liquid penetrant examination of repair welds shall be performed after any required post-weld heat treatment, except for P-No. 1 material which may be examined before or after any required postweld heat treatment.

NE-2538 Elimination of Surface Defects

Surface defects shall be removed by grinding or machining provided the requirements of (a) and (b) below are met:

(a) the depression, after defect elimination, is blended uniformly into the surrounding surface;

(b) when the elimination of the defect reduces the thickness of the section below the minimum required by Article NE-3000, the material shall be repaired in accordance with NE-2539.

NE-2539 Repair by Welding

The Material Organization may repair by welding materials from which defects have been removed, provided the depth of the repair cavity does not exceed one-third of the nominal thickness and the requirements of the following subparagraphs are met. Prior approval of the Certificate Holder shall be obtained.

NE-2539.1 Defect Removal. The defect shall be removed or reduced to an imperfection of acceptable limit by suitable mechanical or thermal cutting or gouging methods and the cavity prepared for repair (NE-4211.1).

NE-2539.2 Qualification of Welding Procedures and Welders. The welding procedure and welders or welding operators shall be qualified in accordance with Article NE-4000 and Section IX.

NE-2539.3 Blending of Repaired Areas. After repair, the surface shall be blended uniformly into the surrounding surface.

NE-2539.4 Examination of Repair Welds. Each repair weld shall be examined by the magnetic particle method (NE-2545) or by the liquid penetrant method (NE-2546). In addition, when the depth of the repair cavity exceeds the lesser of $\frac{3}{8}$ in. (10 mm) or 10% of the section thickness, the repair weld shall be radiographed in accordance with and to the applicable acceptance standards of Article NE-5000. The image quality indicator (IQI) shall be based upon the section thickness of the repaired area.

NE-2539.5 Heat Treatment After Repairs. The product shall be heat treated after repair in accordance with the requirements of NE-4620.

NE-2539.6 Material Report Describing Defects and Repair. Each defect repair that is required to be radiographed shall be described in the Certified Material Test Report. The Certified Material Test Report for each piece shall include a chart which shows the location and size of the prepared cavity, the welding material identification, the welding procedure, the heat treatment, and a report of the results of the examinations, including radiographs.

NE-2540 EXAMINATION AND REPAIR OF FORGINGS AND BARS

NE-2541 Required Examinations

Forgings and bars shall be examined in accordance with the requirements of the material specification, except when magnetic particle or liquid penetrant examination is specifically required by the rules of this Subsection, in which case the examination shall conform to the requirements of NE-2545 or NE-2546 as applicable.

NE-2545 Magnetic Particle Examination

NE-2545.1 Examination Procedure. The procedure for magnetic particle examination shall be in accordance with the methods of Section V, Article 7.

NE-2545.2 Evaluation of Indications.

(a) Mechanical discontinuities at the surface are revealed by the retention of the examination medium. All indications are not necessarily defects, however, since certain metallurgical discontinuities and magnetic permeability variations may produce similar indications which are not relevant.

(b) Any indication in excess of the NE-2545.3 acceptance standards which is believed to be nonrelevant shall be reexamined by the same or other nondestructive examination methods to verify whether or not actual defects are present. Surface conditioning may precede the reexamination. Nonrelevant indications which would mask defects are unacceptable.

(c) Relevant indications are indications which result from imperfections. Linear indications are indications in which the length is more than three times the width. Rounded indications are indications which are circular or elliptical with the length equal to or less than three times the width. Indications resulting from nonmetallic inclusions are not considered relevant indications.

NE-2545.3 Acceptance Standards.

(a) Only imperfections producing indications with major dimensions greater than $\frac{1}{16}$ in. (1.5 mm) shall be considered relevant imperfections.

(b) Imperfections producing the following relevant indications are unacceptable:

(1) any linear indications greater than $\frac{1}{16}$ in. (1.5 mm) long for material less than $\frac{5}{8}$ in. (16 mm) thick, greater than $\frac{1}{8}$ in. (3 mm) long for material from $\frac{5}{8}$ in. (16 mm) thick to under 2 in. (50 mm) thick, and $\frac{3}{16}$ in. (5 mm) long for material 2 in. (50 mm) thick and greater;

(2) rounded indications with dimensions greater than $\frac{1}{8}$ in. (3 mm) for thicknesses less than $\frac{5}{8}$ in. (16 mm) and greater than $\frac{3}{16}$ in. (5 mm) for thicknesses $\frac{5}{8}$ in. (16 mm) and greater;

(3) four or more relevant indications in a line separated by $\frac{1}{16}$ in. (1.5 mm) or less edge to edge;

(4) ten or more relevant indications in any 6 in.² (4 000 mm²) of area whose major dimension is no more than 6 in. (150 mm) with the dimensions taken in the most unfavorable location relative to the indications being evaluated.

NE-2546 Liquid Penetrant Examinations

NE-2546.1 Examination Procedure. The procedure for liquid penetrant examination shall be in accordance with the methods of Section V, Article 6.

NE-2546.2 Evaluation of Indications.

(a) Mechanical discontinuities at the surface are revealed by bleeding out of the penetrant; however, localized surface discontinuities such as may occur from machining marks or surface conditions may produce similar indications which are not relevant.

(b) Any indication in excess of the [NE-2546.3](#) acceptance standards which is believed to be nonrelevant shall be reexamined to verify whether or not actual defects are present. Surface conditioning may precede the reexamination. Nonrelevant indications and broad areas of pigmentation which would mask defects are unacceptable.

(c) Relevant indications are indications which result from imperfections. Linear indications are indications in which the length is more than three times the width. Rounded indications are indications which are circular or elliptical with the length equal to or less than three times the width.

NE-2546.3 Acceptance Standards.

(a) Only imperfections producing indications with major dimensions greater than $\frac{1}{16}$ in. (1.5 mm) shall be considered relevant imperfections.

(b) Imperfections producing the following relevant indications are unacceptable:

(1) any linear indications greater than $\frac{1}{16}$ in. (1.5 mm) long for material less than $\frac{5}{8}$ in. (16 mm) thick, greater than $\frac{1}{8}$ in. (3 mm) long for material from $\frac{5}{8}$ in. (16 mm) thick to under 2 in. (50 mm) thick, and $\frac{3}{16}$ in. (5 mm) long for material 2 in. (50 mm) thick and greater;

(2) rounded indications with dimensions greater than $\frac{1}{8}$ in. (3 mm) for thicknesses less than $\frac{5}{8}$ in. (16 mm) and greater than $\frac{3}{16}$ in. (5 mm) for thicknesses $\frac{5}{8}$ in. (16 mm) and greater;

(3) four or more relevant indications in a line separated by $\frac{1}{16}$ in. (1.5 mm) or less edge to edge;

(4) ten or more relevant indications in any 6 in.² (4 000 mm²) of area whose major dimension is no more than 6 in. (150 mm) with the dimensions taken in the most unfavorable location relative to the indications being evaluated.

NE-2547 Time of Examination

The requirements for time of examination shall be the same as stated in [NE-2537](#).

NE-2548 Elimination of Surface Defects

Elimination of surface defects shall be made in accordance with [NE-2538](#).

NE-2549 Repair by Welding

The requirements for repair by welding shall be the same as stated in [NE-2539](#), except that the depth of repair that is permitted is not limited.

NE-2550 EXAMINATION AND REPAIR OF SEAMLESS AND WELDED (WITHOUT FILLER METAL) TUBULAR PRODUCTS AND FITTINGS**NE-2551 Required Examination**

(a) Wrought seamless tubular products and fittings shall comply with the requirements of [NE-2557](#), [NE-2558](#), and [NE-2559](#) in addition to the basic material specification.

(b) Welded (without filler metal) tubular products and fittings shall comply with the requirements of [NE-2557](#), [NE-2558](#), and [NE-2559](#); in addition, the welds shall be examined by one of the following methods:

(1) ultrasonic examination in accordance with [NE-2552](#);

(2) eddy current examination in accordance with [NE-2554](#);

(3) radiographic examination in accordance with [NE-2553](#).

NE-2552 Ultrasonic Examination⁸

NE-2552.1 Examination Procedure for Welds in Pipe and Tubing.

(a) *Circumferential Direction* $6\frac{3}{4}$ in. (171 mm) O.D. and Smaller. The welds in pipe and tubing shall be examined in two circumferential directions. The procedure for ultrasonic examination of pipe and tubing in the circumferential directions shall be in accordance with SE-213, Standard Method for Ultrasonic Testing of Pipe and Tubing for Longitudinal Discontinuities, and the requirements of this paragraph. The procedure shall provide a sensitivity which will consistently detect defects that produce indications equal to or greater than the indications produced by standard defects included in the reference specimens specified in NE-2552.3.

(b) *Pipe and Tubing Larger Than* $6\frac{3}{4}$ in. (171 mm) O.D. The welds in pipe and tubing shall be examined in two circumferential directions. The procedure for ultrasonic examination of pipe and tubing larger than $6\frac{3}{4}$ in. (171 mm) O.D. shall be in accordance with the requirements of SA-388 for angle beam scanning in the circumferential direction or with the requirements of SE-213. The reference standard shall be in accordance with NE-2552.3.

(c) *Acceptance Standards.* Products with defects that produce indications in excess of the indications produced by the standard defects in the reference specimen are unacceptable unless the defects are eliminated or repaired in accordance with NE-2558 or NE-2559.

NE-2552.2 Examination Procedure for Welds in Fittings.

(a) *Procedure.* The procedure for ultrasonic examination of welds in fittings shall be in accordance with the requirements of recommended practice SA-388 for angle beam examination in two circumferential directions.

(b) *Acceptance Standard.* Fittings shall be unacceptable if angle beam examination results show one or more reflectors which produce indications exceeding in amplitude the indications from the calibrated notch.

NE-2552.3 Reference Specimens.

(a) The reference specimen shall be of the same nominal diameter and thickness and of the same nominal composition and heat-treated condition as the product which is being examined. For circumferential scanning, the standard defects shall be axial notches or grooves on the outside and inside surfaces of the reference specimen and shall have a length of approximately 1 in. (25 mm) or less, a width not to exceed $\frac{1}{16}$ in. (1.5 mm) for a square notch or U-notch, a width proportional to the depth for a V-notch, and a depth not greater than the larger of 0.004 in. (0.10 mm) or 5% of the nominal wall thickness.

(b) The reference specimen shall be long enough to simulate the handling of the product being examined through the examination equipment. When more than one standard defect is placed in a reference specimen, the defects shall be located so that indications from each defect are separate and distinct without mutual interference or amplification. All upset metal and burrs adjacent to the reference notches shall be removed.

NE-2552.4 Checking and Calibration of Equipment.

The proper functioning of the examination equipment shall be checked and the equipment shall be calibrated by the use of the reference specimens, as a minimum:

(a) at the beginning of each production run of a given size and thickness of a given material;

(b) after each 4 hr or less during the production run;

(c) at the end of the production run;

(d) at any time that malfunctioning is suspected.

If, during any check, it is determined that the testing equipment is not functioning properly, all of the product that has been tested since the last valid equipment calibration shall be reexamined.

NE-2553 Radiographic Examination

(a) *General.* When radiographic examination is performed as an alternative for ultrasonic examination of the entire volume of the material, it shall apply to the entire volume of the pipe, tube, or fitting material. Acceptance standards specified for welds shall apply to the entire volume of material examined.

(b) *Examination Procedure.* The radiographic examination shall be performed in accordance with Section V, Article 2, as modified by NE-5111.

(c) *Acceptance Standard.* Welds that are shown by radiography to have any of the following types of discontinuities are unacceptable:

(1) any type of crack or zone of incomplete fusion or penetration;

(2) any other elongated indication which has a length greater than:

(-a) $\frac{1}{4}$ in. (6 mm) for t up to $\frac{3}{4}$ in. (19 mm), inclusive

(-b) $\frac{1}{3}t$ for t from $\frac{3}{4}$ in. (19 mm) to $1\frac{1}{4}$ in. (32 mm), inclusive

(-c) $\frac{3}{4}$ in. (19 mm) for t over $1\frac{1}{4}$ in. (32 mm)

where t is the thickness of the thinner portion of the weld;

(3) any group of aligned indications having an aggregate length greater than t in a length of $12t$, unless the minimum distance between successive indications exceeds $6L$, in which case the aggregate length is unlimited, L being the length of the largest indication;

(4) rounded indications in excess of that shown as acceptable in Section III Appendices, Mandatory Appendix VI.

NE-2554 Eddy Current Examination

This examination method is restricted to materials with uniform magnetic properties and of sizes for which meaningful results can be obtained.

NE-2554.1 Examination Procedure. The procedure for eddy current examination shall provide a sensitivity that will consistently detect defects by comparison with the standard defects included in the reference specimen specified in [NE-2552.3](#). Products with defects that produce indications in excess of the reference standards are unacceptable unless the defects are eliminated or repaired in accordance with [NE-2558](#) or [NE-2559](#) as applicable.

NE-2554.2 Reference Specimens. The reference specimen shall be of the same nominal diameter and thickness and of the same nominal composition and heat-treated condition as the product that is being examined. The standard shall contain tangential or circumferential notches on the outside surface plus a $\frac{1}{16}$ in. (1.5 mm) diameter hole drilled through the wall. These shall be used to establish the rejection level for the product to be tested. The reference notches shall have a depth not greater than the larger of 0.004 in. (0.10 mm) or 5% of the wall thickness. The width of the notch shall not exceed $\frac{1}{16}$ in. (1.5 mm). The length shall be approximately 1 in. (25 mm) or less. The size of reference specimens shall be as specified in [NE-2552.3](#).

NE-2554.3 Checking and Calibration of Equipment. The checking and calibration of examination equipment shall be the same as in [NE-2552.4](#).

NE-2557 Time of Examination

(a) Products that are quenched and tempered shall be examined, as required, after the quenching and tempering heat treatment.

(b) Products that are not quenched and tempered shall receive the required examinations as follows:

(1) Ultrasonic or eddy current examination, when required, shall be performed after final heat treatment, except postweld heat treatment.

(2) Radiographic examination, when required, may be performed prior to any required postweld heat treatment.

(3) Magnetic particle or liquid penetrant examination of welds, including repair welds, shall be performed after final heat treatment, except that the examination may be performed prior to postweld heat treatment for P-No. 1 (Section IX of the Code) materials of 2 in. (50 mm) and less nominal thickness.

(4) Forgings and rolled bars which are to be bored and/or turned to form tubular parts or fittings shall be examined after boring and/or turning, except for threading. Fittings shall be examined after final forming.

(5) When surface examination is required all external surfaces and all accessible internal surfaces shall be examined, except for bolt holes and threads.

NE-2558 Elimination of Surface Defects

Surface defects shall be removed by grinding or machining, provided the requirements of (a) through (c) below are met:

(a) the depression, after defect elimination, is blended uniformly into the surrounding surface;

(b) after defect elimination, the area is examined by the method which originally disclosed the defect to assure that the defect has been removed or reduced to an imperfection of acceptable size;

(c) if the elimination of the defect reduces the thickness of the section below the minimum required to satisfy the rules of [Article NE-3000](#), the product shall be repaired in accordance with [NE-2559](#).

NE-2559 Repair by Welding

Repair of defects shall be in accordance with [NE-2539](#).

NE-2560 EXAMINATION AND REPAIR OF TUBULAR PRODUCTS AND FITTINGS WELDED WITH FILLER METAL

NE-2561 Required Examination

(a) Welded (with filler metal) tubular products, such as pipe made in accordance with SA-358, SA-409, SA-671, SA-672, and SA-691 and fittings made in accordance with the WPW grades of SA-234, SA-403, and SA-420 which are made by welding with filler metal, shall be treated as material; however, inspection by an Inspector and stamping with a Certification Mark with NPT Designator shall be in accordance with Section III requirements. In addition to the Certification Mark with NPT Designator, a numeral 2 shall be stamped below and outside the official Certification Mark.

(b) In addition to the requirements of the material specification and of this Article, all welds shall be examined 100% by radiography in accordance with the basic material specification. When radiographic examination is not specified in the basic material specification, the welds shall be examined in accordance with [NE-2563](#).

(c) Tubular products and fittings which have been radiographed shall be marked to indicate that radiography has been performed. The radiographs and a radiographic report showing radiographs locations shall be provided with the Certified Material Test Report.

(d) The Authorized Inspector shall certify by signing the Partial Data Report Form NM-1 in accordance with NCA-5290.

**Table NE-2571-1
Required Examinations**

Nominal Pipe Size	Item	Applicable Special Requirements for Class MC Castings
...	...	Cast material shall be examined by either the radiographic or the ultrasonic method, or a combination of the two methods. Castings or sections of castings which have coarse grains or configurations which do not yield meaningful results by ultrasonic examination shall be examined by the radiographic method.

NE-2563 Radiographic Examination

The radiographic examination shall be performed in accordance with the requirements of [NE-2553](#).

NE-2567 Time of Examination

The time of examination shall be in accordance with the requirements of [NE-2557](#).

NE-2568 Elimination of Surface Defects

Unacceptable surface defects shall be removed in accordance with the requirements of [NE-2558](#).

NE-2569 Repair by Welding

When permitted by the basic material specification, base material defects shall be repair welded in accordance with the requirements of [NE-2559](#). Repair welding of weld seam defects shall be in accordance with [NE-4450](#).

NE-2570 EXAMINATION AND REPAIR OF STATICALLY AND CENTRIFUGALLY CAST PRODUCTS

In addition to the requirements of the material specifications and of this Article, statically and centrifugally cast products shall comply with the following subparagraphs.

NE-2571 Required Examination

Cast products shall be examined by the radiographic method, except cast ferritic steels, which shall be examined by either the radiographic or the ultrasonic method, or a combination of both methods as required for the product form by [Table NE-2571-1](#).

NE-2572 Time of Nondestructive Examination

NE-2572.1 Acceptance Examinations. Acceptance examinations shall be performed at the time of manufacture as stipulated in the following and [Table NE-2571-1](#).

(a) *Ultrasonic Examination.* Ultrasonic examination, if required, shall be performed at the same stage of manufacture as required for radiography.

(b) *Radiographic Examination.* Radiography may be performed prior to heat treatment and may be performed prior to or after finish machining at the following limiting thicknesses.

(1) For finished thicknesses under 2½ in. (64 mm), castings shall be radiographed within ½ in. (13 mm) or 20% of the finished thickness, whichever is greater. The IQI and the reference radiographs shall be based on the finished thickness.

(2) For finished thicknesses from 2½ in. (64 mm) up to 6 in. (150 mm), castings shall be radiographed within 20% of the finished thickness. The IQI and the acceptance reference radiographs shall be based on the finished thickness.

(3) For finished thicknesses over 6 in. (150 mm), castings shall be radiographed within ½ in. (13 mm) or 15% of the finished thickness, whichever is greater. The IQI and the acceptance reference radiographs shall be based on the finished thickness.

(c) *Magnetic Particle or Liquid Penetrant Examination.* Magnetic particle or liquid penetrant examination shall be performed after the final heat treatment required by the material specification. Repair weld areas shall be examined after postweld heat treatment when a postweld heat treatment is performed, except that repair welds in P-No. 1 (see Section IX of the Code) material 2 in. (50 mm) nominal thickness and less may be examined prior to postweld heat treatment. For cast products with machined surfaces, all finished machine surfaces, except threaded surfaces and small deep holes, shall also be examined by the magnetic particle or the liquid penetrant method.

NE-2573 Provisions for Repair of Base Material by Welding

The Material Organization may repair, by welding, products from which defects have been removed, provided the requirements of this Article are met.

NE-2573.1 Defect Removal. The defects shall be removed or reduced to an imperfection of acceptable size by suitable mechanical or thermal cutting or gouging methods, and the cavity prepared for repair. When thermal cutting is performed, consideration shall be given to preheating the material.

NE-2573.2 Repair by Welding. The Material Organization may repair castings by welding after removing the material containing unacceptable defects. The depth of the repair is not limited. A cored hole or access hole may be closed by the Material Organization by welding in accordance with the requirements of this paragraph.

provided the hole is closed by filler metal only. If the hole is closed by welding in a metal insert, the welding shall be performed by a holder of a Certificate of Authorization in accordance with the requirements of the Code.

NE-2573.3 Qualification of Welding Procedures and Welders. Each manufacturer is responsible for the welding done by his organization and shall establish the procedures and conduct the tests required by [Article NE-4000](#) and by Section IX of the Code in order to qualify both the welding procedures and the performance of welders and welding operators who apply these procedures. He is also responsible for the welding performed by his subcontractors and shall assure himself that the subcontractors conduct the tests required by [Article NE-4000](#) and by Section IX of the Code in order to qualify their welding procedures and the performance of their welders and welding operators.

NE-2573.4 Blending of Repaired Areas. After repair, the surface shall be blended uniformly into the surrounding surface.

NE-2573.5 Examination of Repair Welds. Each repair weld shall be examined by the magnetic particle method in accordance with the requirements of [NE-2577](#) or by the liquid penetrant method in accordance with the requirements of [NE-2576](#). In addition, when radiography is specified in the order for the original casting, repair cavities, the depth of which exceeds the lesser of $\frac{3}{8}$ in. (10 mm) or 10% of the section thickness, shall be radiographed after repair, except that weld slag, including elongated slag, shall be considered as inclusions under Category B of the applicable reference radiographs. The total area of all inclusions, including slag inclusions, shall not exceed the limits of the applicable severity level of Category B of the reference radiographs. The penetrometer and the acceptance standards for radiographic examination of repair welds shall be based on the actual section thickness at the repair area.

NE-2573.6 Heat Treatment After Repairs. The material shall be heat treated after repair in accordance with the heat treatment requirements of [NE-4620](#), except that the heating and cooling rate limitations of [NE-4623](#) do not apply.

NE-2573.7 Elimination of Surface Defects. Surface defects shall be removed by grinding or machining provided the requirements of (a) through (c) below are met:

(a) the depression, after defect elimination, is blended uniformly into the surrounding surface;

(b) after defect elimination, the area is reexamined by the magnetic particle method in accordance with [NE-2577](#) or the liquid penetrant method in accordance with [NE-2576](#) to assure that the defect has been removed or reduced to an imperfection of acceptable size;

(c) if the elimination of the defect reduces the section thickness below the minimum required by the specification or drawing, the casting shall be repaired in accordance with [NE-2539](#).

NE-2573.8 Material Report Describing Defects and Repairs. Each defect repair exceeding in depth the lesser of $\frac{3}{4}$ in. (19 mm) or 10% of the section thickness shall be described in the Certified Material Test Report. The Certified Material Test Report for each piece shall include a chart that shows the location and size of the prepared cavity, the welding material identification, the welding procedure, the heat treatment, and the examination results, including radiographic film, when radiography is specified in the order for the original casting.

NE-2574 Ultrasonic Examination of Ferritic Steel Castings

Ultrasonic examination shall be performed in accordance with Section V, Article 5, T-571.4. Each manufacturer shall certify that the procedure is in accordance with the requirements of [NE-2574](#) and shall make the procedure available for approval upon request.

NE-2574.1 Acceptance Standards.

(a) The Quality Levels of SA-609 as shown in Section V shall apply for the casting thicknesses indicated:

(1) Quality Level 1 for thicknesses up to 2 in. (50 mm);

(2) Quality Level 3 for thicknesses 2 in. to 4 in. (50 mm to 100 mm);

(3) Quality Level 4 for thicknesses greater than 4 in. (100 mm).

(b) In addition to the Quality Level requirements stated in (a) above, the requirements in (1) through (5) below shall apply for both straight beam and angle beam examination.

(1) Areas giving indications exceeding the Amplitude Reference Line with any dimension longer than those specified in the following tabulation are unacceptable:

UT Quality Level	Longest Dimension of Area, in. (mm) [Notes (1)–(3)]
1	1.5 (38)
2	2.0 (50)
3	2.5 (64)
4	3.0 (75)

NOTES:

(1) The areas for the Ultrasonic Quality Levels in SA-609 refer to the surface area on the casting over which a continuous indication exceeding the transfer corrected distance amplitude curve is maintained.

(2) Areas are to be measured from dimensions of the movement of the search unit, using the center of the search unit as the reference point.

NOTES: (Cont'd)

(3) In certain castings, because of very long metal path distances or curvature of the examination surfaces, the surface area over which a given discontinuity is detected may be considerably larger or smaller than the actual area of the discontinuity in the casting, in such cases, other criteria which incorporate a consideration of beam angles or beam spread must be used for realistic evaluation of the discontinuity.

(2) Quality Level 1 shall apply for the volume of castings within 1 in. (25 mm) of the surface regardless of the overall thickness.

(3) Discontinuities indicated to have a change in depth equal to or greater than one-half the wall thickness or 1 in. (25 mm) (whichever is less) are unacceptable.

(4) Two or more imperfections producing indications in the same plane with amplitudes exceeding the Amplitude Reference Line and separated by a distance less than the longest dimension of the larger of the adjacent indications are unacceptable if they cannot be encompassed within an area less than that of the Quality Level specified in (1) above.

(5) Two or more imperfections producing indications greater than permitted for Quality Level 1 for castings less than 2 in. (50 mm) in thickness, greater than permitted for Quality Level 2 for thicknesses 2 in. (50 mm) through 4 in. (100 mm), and greater than permitted for Quality Level 3 for thicknesses greater than 4 in. (100 mm), separated by a distance less than the longest dimension of the larger of the adjacent indications, are unacceptable if they cannot be encompassed in an area less than that of the Quality Level requirements stated in (a) above.

NE-2575 Radiographic Examination

NE-2575.1 Examination. Cast pressure-retaining materials shall be examined by the radiographic method when specified in the order for the original castings, except that cast ferritic steels may be examined by either the radiographic or the ultrasonic method, or a combination of both methods. Castings or sections of castings that have coarse grains or configurations that do not yield meaningful examination results by the ultrasonic method shall be examined by the radiographic method.

NE-2575.2 Extent. Radiographic examination shall be performed on pressure-retaining castings used in the construction of Class MC vessels. The extent of radiographic coverage shall be of the maximum feasible volume and, when the shape of the casting precludes complete coverage, the coverage shall be at least as exemplified in Figure NE-2575.2-1.

NE-2575.3 Examination Requirements. Radiographic examination shall be performed in accordance with Section V, Article 2, Mandatory Appendix VII, Radiographic Examination of Metallic Castings, with the following modifications:

(a) The geometric unsharpness limitations of Section V, Article 2, T-274.2 need not be met.

(b) The examination procedure or report shall also address the following:

(1) type and thickness of filters, if used

(2) for multiple film technique, whether viewing is to be single or superimposed, if used

(3) blocking or masking technique, if used

(4) orientation of location markers

(5) description of how internal markers, when used, locate the area of interest

(c) The location of location markers (e.g., lead numbers or letters) shall be permanently stamped on the surface of the casting in a manner permitting the area of interest on a radiograph to be accurately located on the casting and providing evidence on the radiograph that the extent of coverage required by NE-2575.2 has been obtained. For castings or sections of castings where stamping is not feasible, the radiographic procedure shall so state and a radiographic exposure map shall be provided.

Figure NE-2575.2-1
Typical Pressure-Retaining Parts of Vessels (21)

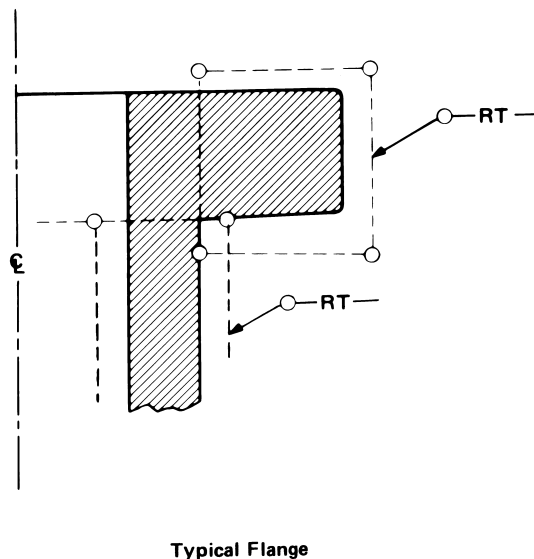

GENERAL NOTES:

(a) Radiographic examination areas shall be indicated by a circle at each change of direction. The examination symbol for radiography shall be indicated as RT.

(b) For nondestructive examination areas of revolution, the area shall be indicated by the examine-all-around symbol: – RT – σ .

(c) The sketch is typical and is to be used as a guide for minimum required coverage for other configurations.

NE-2575.6 Acceptance Criteria. Castings shall meet the acceptance requirements of Severity Level 2 of ASTM E446, Reference Radiographs for Steel Castings up to 2 in. (50 mm) in Thickness; ASTM E186, Reference Radiographs for Heavy-Walled [2 in. to 4½ in. (50 mm to 114 mm)] Steel Castings; or ASTM E280, Reference Radiographs for Heavy-Walled [4½ in. to 12 in. (114 mm to 300 mm)] Steel Castings; as applicable for the thickness being radiographed, except that Category D, E, F, or G defects are not acceptable. The requirements of ASTM E280 shall apply for castings over 12 in. (300 mm) in thickness.

NE-2576 Liquid Penetrant Examination

(a) Castings shall be examined, if required, on all accessible surfaces by the liquid penetrant method in accordance with Section V of the Code.

(b) *Evaluation of Indications.* All indications shall be evaluated in terms of the acceptance standards. Mechanical discontinuities intersecting the surface are indicated by bleeding out of the penetrant; however, localized surface discontinuities as may occur from machining marks, scale, or dents may produce indications which are not relevant. Any indication in excess of the acceptance standards believed to be nonrelevant shall be reexamined to verify whether actual defects are present. Surface conditioning may precede the reexamination. Nonrelevant indications and broad areas of pigmentation that would mask indications of defects are unacceptable. Relevant indications are those which result from imperfections and have a major dimension greater than 1/16 in. (1.5 mm). Linear indications are those whose length is more than three times the width. Rounded indications are those which are circular or elliptical with the length less than three times the width.

(c) *Acceptance Standards.* The following relevant indications are unacceptable:

(1) linear indications greater than 1/16 in. (1.5 mm) long for materials less than 5/8 in. (16 mm) thick, greater than 1/8 in. (3 mm) long for materials from 5/8 in. (16 mm) thick to under 2 in. (50 mm) thick, and 3/16 in. (5 mm) long for materials 2 in. (50 mm) thick and greater;

(2) rounded indications with dimensions greater than 1/8 in. (3 mm) for thicknesses less than 5/8 in. (16 mm) and greater than 3/16 in. (3 mm) for thicknesses 5/8 in. (16 mm) and greater;

(3) four or more indications in a line separated by 1/16 in. (1.5 mm) or less edge to edge;

(4) ten or more indications in any 6 in.² (4 000 mm²) of surface with the major dimension of this area not to exceed 6 in. (150 mm) taken in the most unfavorable orientation relative to the indications being evaluated.

NE-2577 Magnetic Particle Examination (for Ferritic Steel Products Only)

(a) Castings of magnetic material shall be examined, if required, on all accessible surfaces by a magnetic particle method in accordance with Section V of the Code.

(b) *Evaluation of Indications.* All indications shall be evaluated in terms of the acceptance standards. Mechanical discontinuities intersecting the surface are indicated by retention of the examination medium. All indications are not necessarily defects since certain metallurgical discontinuities and magnetic permeability variations may produce indications that are not relevant. Any indication in excess of the acceptance standard believed to be nonrelevant shall be reexamined to verify whether actual defects are present. Nonrelevant indications which would mask indications of defects are unacceptable. Surface conditioning may precede the reexamination. Relevant indications are those which result from imperfections and have a major dimension greater than 1/16 in. (1.5 mm). Linear indications are those whose length is more than three times the width. Rounded indications are those which are circular or elliptical with the length less than three times the width.

(c) *Acceptance Standards.* The following relevant indications are unacceptable:

(1) linear indications greater than 1/16 in. (1.5 mm) long for materials less than 5/8 in. (16 mm) thick, greater than 1/8 in. (3 mm) long for materials from 5/8 in. (16 mm) thick to under 2 in. (50 mm) thick, and 3/16 in. (5 mm) long for materials 2 in. (50 mm) thick and greater;

(2) rounded indications with dimensions greater than 1/8 in. (3 mm) for thicknesses less than 5/8 in. (16 mm) and greater than 3/16 in. (5 mm) for thicknesses 5/8 in. (16 mm) and greater;

(3) four or more relevant indications in a line separated by 1/16 in. (1.5 mm) or less edge to edge;

(4) ten or more relevant indications in any 6 in.² (4 000 mm²) of surface with the major dimension of this area not to exceed 6 in. (150 mm) taken in the most unfavorable orientation relative to the indications being evaluated.

NE-2580 EXAMINATION OF BOLTS, STUDS, AND NUTS

NE-2581 Requirements

All bolting material shall be visually examined in accordance with [NE-2582](#).

NE-2582 Visual Examination

The final surfaces of threads, shanks, and heads shall be visually examined for workmanship, finish, and appearance in accordance with the requirements of ASTM F788 for bolting material and ASTM F812 for nuts. The visual examination personnel shall be trained and qualified in

accordance with the Material Organization's Quality System Program or the Certificate Holder's Quality Assurance Program. These examinations are not required to be performed either in accordance with procedures qualified to [NE-5100](#) or by personnel qualified in accordance with [NE-5500](#).

NE-2600 MATERIAL ORGANIZATIONS' QUALITY SYSTEM PROGRAMS

NE-2610 DOCUMENTATION AND MAINTENANCE OF QUALITY SYSTEM PROGRAMS

(a) Except as provided in (b) below, Material Organizations shall have a Quality System Program which meets the requirements of NCA-3800.

(b) The requirements of NCA-3862 shall be met as required by [NE-2130](#). The other requirements of NCA-3800 and NCA-4200 need not be used by Material Organizations for small products, as defined in (c) below, and for material which is allowed by this Subsec-

tion to be furnished with a Certificate of Compliance. For these products, the Certificate Holder's Quality Assurance Program (NCA-4100) shall include measures to provide assurance that the material is furnished in accordance with the material specification and with the applicable special requirements of this Subsection.

(c) For the purpose of this paragraph, small products are defined as given in (1) through (3) below:

(1) pipe, tube, pipe fittings, and flanges NPS 2 (DN 50) and less;

(2) bolting materials, including studs, nuts, and bolts of 1 in. (25 mm) nominal diameter and less;

(3) bars with a nominal cross-sectional area of 1 in.² (650 mm²) and less.

NE-2700 DIMENSIONAL STANDARDS

NE-2710 STANDARDS AND SPECIFICATIONS

Dimensions of standard items shall comply with the standards and specifications listed in Table NCA-7100-1.

ARTICLE NE-3000

DESIGN

NE-3100 GENERAL DESIGN

NE-3110 LOADING CRITERIA

NE-3111 Loading Conditions

The loadings that shall be taken into account in designing a vessel shall include, but are not limited to, those in (a) through (i) below

- (a) internal and external pressure
- (b) impact loads, including rapidly fluctuating pressure
- (c) weight of the vessel and normal contents under all conditions, including additional pressure due to static and dynamic head of liquids
- (d) superimposed loads such as other components, operating equipment, insulation, corrosion resistant or erosion resistant linings, and piping
- (e) wind loads, snow loads, and vibration loads where specified
- (f) reactions of supporting lugs, rings, saddles, or other types of supports
- (g) temperature effects
- (h) reactions to steam and water jet impingement
- (i) earthquake loads

NE-3112 Design Loadings

The containment vessel or portions thereof may be exposed to more than one pressure, temperature, and mechanical load condition as provided in the Design Specifications. The specified design parameters for Design Loadings shall be called Design Pressure, Design Temperature, and Design Mechanical Loads. These specified design parameters shall be used in computations to show compliance with the requirements on Design Loadings in [NE-3220](#).

NE-3112.1 Design Pressure. The design internal pressure shall not be less than 100% of the maximum containment internal pressure under conditions for which the containment function is required. The design external pressure shall not be less than 100% of the maximum containment external pressure. Stability of the vessel shell may be provided by structures bearing directly against the shell or by structural attachments.

NE-3112.2 Design Temperature.

(a) The Design Temperature shall not be less than the maximum containment temperature at the coincident maximum containment pressure. The Design Temperature shall be used in all computations involving Design Pressure and coincidental Design Mechanical Loads.

(b) Where a vessel is heated by external or internal heat generation, the effect of such heating shall be incorporated in the establishment of the vessel Design Temperature.

NE-3112.3 Design Mechanical Loads. The values of dead loads and any hydrostatic loads coincident with Design Pressure shall be designated as Design Mechanical Loads. These mechanical loads shall be used in all computations involving Design Pressure and Design Temperature.

NE-3112.4 Allowable Stress Intensity and Stress Values.

(a) Allowable stress intensity values, S_m and S_{mc} , shall be defined as follows:

(1) S_m is the value given in Section II, Part D, Subpart 1, Tables 2A and 2B for materials other than bolting and Table 4 for bolting.

(2) S_{mc} is 1.1 times the value given in Section II, Part D, Subpart 1, Tables 1A and 1B, except S_{mc} shall not exceed 90% of the material's yield strength at temperature shown in Section II, Part D, Subpart 1, Table Y-1.

(b) Allowable stress values, S , for materials other than bolting shall be 1.1 times the value given in Section II, Part D, Subpart 1, Tables 1A and 1B, except S shall not exceed 90% of the material's yield strength at temperature shown in Section II, Part D, Subpart 1, Table Y-1. For bolting, S is 1.1 times the value given in Section II, Part D, Subpart 1, Table 3.

(c) The materials shall not be used at metal and design temperatures that exceed the temperature limit established in the allowable stress or stress intensity tables. The values in the tables may be interpolated for intermediate temperatures.

(d) The basis for establishing allowable stress intensity and stress values is given in Section III Appendices, Mandatory Appendix III.

(21) NE-3113 Service Limits

Each Service Loading to which the component may be subjected shall be categorized in accordance with the following definitions and shall be described in the Design Specifications (NCA-3211.19) in such detail as will provide a complete basis for construction in accordance with these rules. The Service Limit categories shall be as defined in the next four subparagraphs.

NE-3113.1 Level A Service Limits. Level A Service Limits apply to all sustained loads in combination with the plant or system design basis accident loads for which the containment function is required. Other loads, either separately or in combination with the above loads, may also be considered under this service limit.

NE-3113.2 Level B Service Limits. This service limit applies to those applicable loads subject to Level A Service Limits in combination with loads due to natural phenomena for which the plant must remain operational. Other loads, either separately or in combination with the above loads, may also be considered under this service limit.

NE-3113.3 Level C Service Limits. This service limit applies to those applicable loads subject to Level A and B Service Limits in combination with loads due to natural phenomena for which safe shutdown of the plant is required. Other loads, either separately or in combination with the above loads, may also be considered under this service limit.

NE-3113.4 Level D Service Limits. This service limit applies to those loads subject to other service limits in combination with loadings of a local dynamic nature, such as jet impingement, pipe whip, and pipe reaction loads resulting from a postulated pipe rupture, for which the containment function is required.

NE-3113.5 Service Limits. The Service Limits for design by analysis are specified in [NE-3200](#). The Service Limits for design by equation are specified in [NE-3300](#).

NE-3114 Testing Conditions

Testing conditions are those tests in addition to the ten hydrostatic or pneumatic tests permitted by [NE-6222](#) and [NE-6322](#), including leak tests or subsequent hydrostatic or pneumatic tests.

NE-3120 SPECIAL CONSIDERATIONS**NE-3121 Corrosion**

Material subject to thinning by corrosion, erosion, mechanical abrasion, or other environmental effects shall have provision made in the Design Specifications for these effects by indicating the increase in the thickness of the base metal over that determined by the design equa-

tions ([NE-2160](#)). Material added or included for these purposes need not be of the same thickness for all areas of the component if different rates of attack are indicated for the various areas. It should be noted that the tests on which the design fatigue curves (Section III Appendices, Mandatory Appendix I) are based did not include tests in the presence of corrosive environments which might accelerate fatigue failure.

NE-3122 Cladding

The rules of this paragraph apply to the design and analysis of clad components constructed of material permitted under this Subsection. When corrosion or erosion of the cladding material is expected, the cladding thickness shall be increased by an amount that in the judgment of the Owner will provide the desired service life.

NE-3122.1 Primary Stresses. When stress analysis is required, no structural strength shall be attributed to the cladding in satisfying [NE-3221](#).

NE-3122.2 Design Dimensions. The dimensions given in (a) and (b) below shall be used in the design of the component.

(a) For components subjected to internal pressure, the inside diameter shall be taken at the nominal inner face of the cladding.

(b) For components subjected to external pressure, the outside diameter shall be taken at the outer face of the base metal.

NE-3122.3 Bearing Stresses. In satisfying [NE-3227.1](#), the presence of cladding shall be included.

NE-3122.4 Maximum Allowable Stress Values.

(a) *Integrally Clad Plate Without Credit for Full Cladding Thickness.* Except as permitted in (b) below, design calculations shall be based on the total thickness of the clad plates less the specified nominal minimum thickness of cladding. A reasonable excess thickness either of the actual cladding or of the same thickness of corrosion resistant weld metal may be included in the design calculations as an equal thickness of base plate. The maximum allowable stress value shall be that given for the base plate material as defined in [NE-3112.4\(b\)](#).

(b) *Integrally Clad Plate With Credit for Cladding Thickness.* When clad plate conforms to one of the specifications listed in [NE-2127\(a\)](#) and the joints are completed by depositing corrosion resisting weld metal over the weld in the base plate to restore the cladding, the design calculations may be based on a thickness equal to the nominal thickness of the base plate plus S_c/S_b times the nominal thickness of the cladding after any allowance provided for corrosion has been deducted, where

S_b = maximum allowable stress value for the base plate at the Design Temperature, psi (MPa)

S_c = maximum allowable stress value for the cladding at the Design Temperature, psi (MPa)

When S_c is greater than S_b , the multiplier S_c/S_b shall be taken equal to unity. The maximum allowable stress value shall be that given for the base plate material as defined in [NE-3112.4\(b\)](#).

NE-3122.5 Maximum Allowable Temperature.

(a) When the design calculations are based on the thickness of base plate exclusive of cladding thickness, the maximum service metal temperature of the vessel shall be that allowed for the base plate material.

(b) When the design calculations are based on the full thickness of clad plate as permitted in [NE-3122.4\(b\)](#), the maximum service metal temperature shall be the lower of the values allowed for the base plate material and the cladding material.

NE-3123 Welds Between Dissimilar Metals

In satisfying the requirements of this subarticle, caution should be exercised in design and construction involving dissimilar metals having different coefficients of thermal expansion.

NE-3125 Configuration

Accessibility to permit the examinations required by the Edition and Addenda of Section XI as specified in the Design Specification for the component shall be provided in the design of the component.

NE-3130 GENERAL DESIGN RULES

NE-3131 General Requirements

(a) The containment vessel design shall be such that the rules of [NE-3200](#) are satisfied. However, in the absence of substantial mechanical or thermal loads other than pressure, the rules of [NE-3300](#) may be used in lieu of the rules of [NE-3200](#) for those configurations which are explicitly treated in [NE-3300](#). For this provision, *substantial loads* are defined as those that cumulatively result in stresses that exceed 10% of the primary stresses induced by the Design Pressure, such stresses being defined as *maximum principal stresses*.

(b) For vessels, or portions thereof, designed to the rules of [NE-3200](#), the provisions of [NE-3133](#) may be used, if applicable, in lieu of the rules of [NE-3222](#). For those portions designed to the rules of [NE-3300](#), the requirements of [NE-3133](#) shall be met.

NE-3132 Dimensional Standards for Standard Products

Dimensions of standard products shall comply with the standards and specifications listed in Table NCA-7100-1 when the standard or specification is referenced in the specific design subarticle. However, compliance with these standards does not replace or eliminate the requirements for stress analysis when called for by the design subarticle for a specific component.

NE-3133 Components Under External Loading

NE-3133.1 General. Rules are given in this paragraph for determining the thickness under external pressure loading in spherical shells, cylindrical shells with or without stiffening rings, and tubular products consisting of pipes, tubes, and fittings. Charts for determining the stresses in shells, hemispherical heads, and tubular products are given in Section II, Part D, Subpart 3.

NE-3133.2 Nomenclature. The symbols used in this paragraph are defined as follows:

A = factor determined from Section II, Part D, Subpart 3, Figure G and used to enter the applicable material chart in Section II, Part D, Subpart 3. For the case of cylinders having D_o/T values less than 10, see [NE-3133.3\(b\)](#). Also, factor determined from the applicable chart in Section II, Part D, Subpart 3 for the material used in a stiffening ring, corresponding to the factor B and the design metal temperature for the shell under consideration.

A_s = cross-sectional area of a stiffening ring

B = factor determined from the applicable chart in Section II, Part D, Subpart 3 for the material used in a shell or stiffening ring at the design metal temperature, psi (MPa)

D_o = outside diameter of the cylindrical shell course or tube under consideration

E = modulus of elasticity of material at Design Temperature, psi (MPa). For external pressure and axial compression design in accordance with this section, the modulus of elasticity to be used shall be taken from the applicable materials chart in Section II, Part D, Subpart 3. (Interpolation may be made between lines for intermediate temperatures.) The modulus of elasticity values shown in Section II, Part D, Subpart 3 for material groups may differ from those values listed in Section II, Part D, Subpart 2, Table TM for specific materials. Section II, Part D, Subpart 3 values shall be applied only to external pressure and axial compression design.

I = available moment of inertia of the stiffening ring about its neutral axis, parallel to the axis of the shell

- I' = available moment of inertia of the combined ring-shell cross section about its neutral axis, parallel to the shell. The width of the shell which is taken as contributing to the combined moment of inertia shall not be greater than $1.10\sqrt{D_o T_n}$ and shall be taken as lying one-half on each side of the centroid of the ring. Portions of shell plates shall not be considered as contributing area to more than one stiffening ring.
- I_s = required moment of inertia of the stiffening ring about its neutral axis parallel to the axis of the shell
- I'_s = required moment of inertia of the combined ring-shell section about its neutral axis parallel to the axis of the shell
- L = total length of a tube between tubesheets, or the design length of a vessel section, taken as the largest of the following:
- (a) the distance between head tangent lines plus one-third of the depth of each head if there are no stiffening rings
 - (b) the greatest center-to-center distance between any two adjacent stiffening rings, or
 - (c) the distance from the center of the first stiffening ring to the head tangent line plus one-third of the depth of the head, all measured parallel to the axis of the vessel
- L_s = one-half of the distance from the center line of the stiffening ring to the next line of support on one side, plus one-half of the center line distance to the next line of support on the other side of the stiffening ring, both measured parallel to the axis of the component. A line of support is:
- (a) a stiffening ring that meets the requirements of this paragraph
 - (b) a circumferential line on a head at one-third the depth of the head from the head tangent line, or
 - (c) a circumferential connection to a jacket for a jacketed section of a cylindrical shell
- P = external design pressure, psi (MPa) (gage or absolute, as required)
- P_a = allowable external pressure, psi (MPa) (gage or absolute, as required)
- R = inside radius of spherical shell
- S' = the lesser of 1.82 times the allowable stress at design metal temperature as defined in [NE-3112.4\(b\)](#) or 0.9 times the tabulated yield strength at design metal temperature from Section II, Part D, Subpart 1, Table Y-1, psi (MPa)
- T = minimum required thickness of cylindrical shell or tube, or spherical shell
- T_n = nominal thickness used, less corrosion allowance, of a cylindrical shell or tube

NE-3133.3 Cylindrical Shells. The thickness of a cylindrical shell under external pressure shall be determined by the procedure given in [\(a\)](#) or [\(b\)](#) below.

(a) Cylinders having D_o/T values ≥ 10 :

Step 1. Assume a value for T and determine the ratios L/D_o and D_o/T .

Step 2. Enter Section II, Part D, Subpart 3, Figure G at the value of L/D_o determined in [Step 1](#). For values of L/D_o greater than 50, enter the chart at a value of $L/D_o = 50$. For values of L/D_o less than 0.05, enter the chart at a value of L/D_o of 0.05.

Step 3. Move horizontally to the line for the value of D_o/T determined in [Step 1](#). Interpolation may be made for intermediate values of D_o/T . From this point of intersection, move vertically downward to determine the value of factor A .

Step 4. Using the value of A calculated in [Step 3](#), enter the applicable material chart in Section II, Part D, Subpart 3 for the material under consideration. Move vertically to an intersection with the material/temperature line for the Design Temperature. Interpolation may be made between lines for intermediate temperatures. In cases where the value of A falls to the right of the end of the material/temperature line, assume an intersection with the horizontal projection of the upper end of the material/temperature line. For values of A falling to the left of the material/temperature line, see [Step 7](#).

Step 5. From the intersection obtained in [Step 4](#), move horizontally to the right and read the value of B psi (MPa).

Step 6. Using this value of B , calculate the value of the maximum allowable external pressure P_a using the following equation:

$$P_a = \frac{4B}{3(D_o/T)}$$

Step 7. For values of A falling to the left of the applicable material/temperature line, the value of P_a can be calculated by using the following equation:

$$P_a = \frac{2AE}{3(D_o/T)}$$

Step 8. Compare P_a with P . If P_a is smaller than P , select a larger value for T and repeat the design procedure until a value of P_a is obtained that is equal to or greater than P .

(b) Cylinders having D_o/T values < 10 :

Step 1. Using the same procedure as given in [\(a\)](#) above, obtain the value of B . For values of D_o/T less than 4, the value of A can be calculated using the following equation:

$$A = \frac{1.1}{(D_o/T)^2}$$

For values of A greater than 0.10, use a value of 0.10.

Step 2. Using the value of B obtained in [Step 1](#), calculate a value P_{a1} using the following equation:

$$P_{a1} = \left[\frac{2.167}{(D_o/T)} - 0.0833 \right] B$$

Step 3. Calculate a value P_{a2} using the following equation:

$$P_{a2} = \frac{2S'}{(D_o/T)} \left[1 - \frac{1}{(D_o/T)} \right]$$

Step 4. The smaller of the values of P_{a1} calculated in [Step 2](#), or P_{a2} calculated in [Step 3](#), shall be used for the maximum allowable external pressure P_a . Compare P_a with P . If P_a is smaller than P , select a larger value for T and repeat the design procedure until a value for P_a is obtained that is equal to or greater than P .

NE-3133.4 Spherical Shells and Formed Heads.

(a) Spherical Shells. The minimum required thickness of a spherical shell under external pressure, either seamless or of built-up construction with butt joints, shall be determined by the procedure given in [Steps 1](#) through [6](#).

Step 1. Assume a value for T and calculate the value of factor A using the following equation:

$$A = \frac{0.125}{(R/T)}$$

Step 2. Using the value of A calculated in [Step 1](#), enter the applicable material chart in Section II, Part D, Subpart 3 for the material under consideration. Move vertically to an intersection with the material/temperature line for the Design Temperature. Interpolation may be made between lines for intermediate temperatures. In cases where the value at A falls to the right of the end of the material/temperature line, assume an intersection with the horizontal projection of the upper end of the material/temperature line. For values at A falling to the left of the material/temperature line, see [Step 5](#).

Step 3. From the intersection obtained in [Step 2](#), move horizontally to the right and read the value of factor B psi (MPa).

Step 4. Using the value of B obtained in [Step 3](#), calculate the value of the maximum allowable external pressure P_a using the following equation:

$$P_a = \frac{B}{(R/T)}$$

Step 5. For values of A falling to the left of the applicable material/temperature line for the Design Temperature, the value of P_a can be calculated using the following equation:

$$P_a = \frac{0.0625E}{(R/T)^2}$$

Step 6. Compare P_a obtained in [Step 4](#) or [Step 5](#) with P . If P_a is smaller than P , select a larger value for T and repeat the design procedure until a value for P_a is obtained that is equal to or greater than P .

(b) The nomenclature defined below is used in the equations of [\(c\)](#) through [\(e\)](#) below.

D_o = outside diameter of the head skirt or the outside diameter of a cone head at the point under consideration, measured perpendicular to the longitudinal axis of the cone, in. (mm)

K_1 = a factor depending on the ellipsoidal head proportions, given in [Table NE-3332.2-1](#)

R = for hemispherical heads, the inside radius in the corroded condition, in. (mm)

= for ellipsoidal heads, the equivalent inside spherical radius taken as $K_1 D_o$ in the corroded condition, in. (mm)

= for torispherical heads, the inside radius of the crown portion of the head in the corroded condition, in. (mm)

T = minimum required thickness of head after forming, exclusive of corrosion allowance, in. (mm)

(c) Hemispherical Heads. The required thickness of a hemispherical head having pressure on the convex side shall be determined in the same manner as outlined in [\(a\)](#) above for determining the thickness for a spherical shell.

(d) Ellipsoidal Heads. The required thickness of an ellipsoidal head having pressure on the convex side, either seamless or of built-up construction with butt joints, shall not be less than that determined by the following procedure:

Step 1. Assume a value for T and calculate the value of factor A using the following equation:

$$A = \frac{0.125}{(R/T)}$$

Step 2. Using the value of A calculated in [Step 1](#), follow the same procedure as that given for spherical shells in [\(a\)Step 2](#) through [\(a\)Step 6](#).

(e) Torispherical Heads. The required thickness of a torispherical head having pressure on the convex side, either seamless or of built-up construction with butt joints, shall not be less than that determined by the same design procedure as is used for ellipsoidal heads given in [\(d\)](#) above, using the appropriate value for R .

NE-3133.5 Stiffening Rings for Cylindrical Shells.

(a) The required moment of inertia of a circumferential stiffening ring shall not be less than that determined by one of the following two equations:

$$I_s = \frac{D_o^2 L_s \left(T + \frac{A_s}{L_s} \right) A}{14}$$

$$I_s' = \frac{D_o^2 L_s \left(T + \frac{A_s}{L_s} \right) A}{10.9}$$

If the stiffeners should be so located that the maximum permissible effective shell sections overlap on either or both sides of a stiffener, the effective shell section for the stiffener shall be shortened by one-half of each overlap.

(b) The available moment of inertia I or I' for a stiffening ring shall be determined by the following procedure.

Step 1. Assuming that the shell has been designed and D_o , L_s , and T_n are known, select a member to be used for the stiffening ring and determine its cross-sectional area A_s . Then calculate factor B using the following equation:

$$B = 3/4 \left(\frac{PD_o}{T_n + A_s/L_s} \right)$$

Step 2. Enter the right side of the applicable material chart in Section II, Part D, Subpart 3 for the material under consideration at the value of B determined by [Step 1](#). If different materials are used for the shell and stiffening ring, use the material chart resulting in the larger value of A in [Step 4](#) or [Step 5](#) below.

Step 3. Move horizontally to the left to the material/temperature line for the design metal temperature. For values of B falling below the left end of the material/temperature line, see [Step 5](#).

Step 4. Move vertically to the bottom of the chart and read the value of A .

Step 5. For values of B falling below the left end of the material/temperature line for the Design Temperature, the value of A can be calculated using the equation:

$$A = \frac{2B}{E}$$

Step 6. Compute the value of the required moment of inertia from the equations for I_s or I_s' above.

Step 7. Calculate the available moment of inertia I or I' of the stiffening ring using the section corresponding to that used in [Step 6](#).

Step 8. If the required moment of inertia is greater than the moment of inertia for the section selected in [Step 1](#), a new section with a larger moment of inertia must be selected and a new moment of inertia determined. If the required moment of inertia is smaller than the moment of inertia for the section selected in [Step 1](#), that section should be satisfactory.

(c) For fabrication and installation requirements for stiffening rings, see [NE-4437](#).

NE-3133.6 Cylinders Under Axial Compression. The maximum allowable compressive stress to be used in the design of cylindrical shells and tubular products subjected to loadings that produce longitudinal compressive stresses in the shell shall be the smaller of the following values:

(a) the S value for the applicable material at Design Temperature as defined in [NE-3112.4\(b\)](#).

(b) the value of B determined from the applicable chart in Section II, Part D, Subpart 3, using the following definitions for the symbols on the charts:

R = the inside radius of the cylindrical shell or tubular product, in. (mm)

T = minimum required thickness of the shell or tubular product, exclusive of the corrosion allowance, in. (mm)

The value of B shall be determined from the applicable chart contained in Section II, Part D, Subpart 3 as given in [Steps 1](#) through [5](#).

Step 1. Using the selected values of T and R , calculate the value of factor A using the following equation:

$$A = \frac{0.125}{(R/T)}$$

Step 2. Using the value of A calculated in [Step 1](#), enter the applicable material chart in Section II, Part D, Subpart 3 for the material under consideration. Move vertically to an intersection with material/temperature line for the Design Temperature. Interpolation may be made between lines for intermediate temperatures. In cases where the value at A falls to the right of the end of the material/temperature line, assume an intersection with the horizontal projection of the upper end of the material/temperature line. For values of A falling to the left of the material/temperature line, see [Step 4](#).

Step 3. From the intersection obtained in [Step 2](#), move horizontally to the right and read the value of factor B . This is the maximum allowable compressive stress for the values of T and R used in [Step 1](#).

Step 4. For values of A falling to the left of the applicable material/temperature line, the value of B shall be calculated using the following equation:

$$B = \frac{AE}{2}$$

Step 5. Compare the value of B determined in [Step 3](#) or [Step 4](#) with the computed longitudinal compressive stress in the cylindrical shell or tube, using the selected values of T and R . If the value of B is smaller than the computed compressive stress, a greater value of T must be selected and the design procedure repeated until a value of B is obtained which is greater than the

compressive stress computed for the loading on the cylindrical shell or tube.

NE-3133.7 Conical Heads. The required thickness of a conical head under pressure on the convex side shall not be less than that determined by (a), (b), and (c) below.

(a) When one-half of the included apex angle of the cone is equal to or less than $22\frac{1}{2}$ deg, the thickness of the cone shall be the same as the required thickness of a cylindrical shell, the length of which equals the axial length of the cone or the axial distance center-to-center of stiffening rings, if used, and the outside diameter of which is equal to the outside diameter at the large end of the cone or section between stiffening rings.

(b) When one-half of the included apex angle of the cone is greater than $22\frac{1}{2}$ deg and not more than 60 deg, the thickness of the cone shall be the same as the required thickness of a cylindrical shell, the outside diameter of which equals the largest inside diameter of the cone measured perpendicular to the cone axis, and the length of which equals an axial length that is the lesser of either the distance center-to-center of stiffening rings, if used, or the largest inside diameter of the section of the cone considered.

(c) When one-half of the included apex angle of the cone is greater than 60 deg, the thickness of the cone shall be the same as the required thickness for a flat head under external pressure, the diameter of which equals the largest inside diameter of the cone (NE-3325).

NE-3134 Material Properties

Values for intermediate temperatures may be found by interpolation.

NE-3134.1 Yield Strength Values. The values of yield strength S_y shall be those given in Section II, Part D, Subpart 1, Table Y-1.

NE-3134.2 Ultimate Tensile Strength Values. The values of ultimate tensile strength shall be those given in Section II, Part D, Subpart 1, Table U.

NE-3134.3 Coefficients of Thermal Conductivity and Thermal Diffusivity. The values shall be those given in Section II, Part D, Subpart 2, Table TCD.

NE-3134.4 Coefficients of Thermal Expansion. The values of thermal expansion coefficients shall be those given in Section II, Part D, Subpart 2, Table TE.

NE-3134.5 Modulus of Elasticity Values. The values of modulus of elasticity shall be those given in Section II, Part D, Subpart 2, Table TM.

NE-3134.6 Allowable Stress Intensity and Stress Values. The allowable stress intensity values, S_m and S_{mc} , and allowable stress value, S , shall be as defined in NE-3112.4.

NE-3135 Attachments

(a) Except as in (c) and (d) below, attachments and connecting welds within the jurisdictional boundary of the containment vessel as defined in NE-1130 shall meet the stress limits of NE-3200 or NE-3300.

(b) The design of the containment vessel shall include consideration of the interaction effects and loads transmitted through the attachment to and from the pressure-retaining portion of the vessel. Thermal stresses, stress concentrations, and restraint of the pressure-retaining portion of the vessel shall be considered.

(c) Beyond $2t$ from the pressure-retaining portion of the containment vessel, where t is the nominal thickness of the pressure-retaining material, the appropriate design rules of Article NF-3000 may be used as a substitute for the design rules of Article NE-3000 for portions of attachments which are in the vessel support load path.

(d) Nonstructural attachments shall meet the requirements of NE-4435.

NE-3200 DESIGN BY ANALYSIS

NE-3210 DESIGN CRITERIA

NE-3211 General Requirements for Acceptability

The requirements for the acceptability of a design by analysis are given in (a) and (b) below.

(a) The design shall be such that stress intensities do not exceed the applicable limits at temperature described in this subarticle.

(b) In addition to the requirement in (a) above, the buckling stress shall be considered in accordance with NE-3222.

NE-3212 Basis for Determining Stresses

The theory of failure used in the rules of this Subsection for combining stresses is the maximum shear stress theory. The maximum shear stress at a point is equal to one-half the difference between the algebraically largest and the algebraically smallest of the three principal stresses at the point.

NE-3213 Terms Relating to Stress Analysis

Terms used in this Subsection relating to stress analysis are defined in the following subparagraphs.

NE-3213.1 Stress Intensity. Stress intensity is defined as twice the maximum shear stress, which is the difference between the algebraically largest principal stress and the algebraically smallest principal stress at a given point. Tensile stresses are considered positive and compressive stresses are considered negative. This definition of stress intensity is not related to the definition of stress intensity applied in the field of Fracture Mechanics.

NE-3213.2 Gross Structural Discontinuity. Gross structural discontinuity is a geometric or material discontinuity that affects the stress or strain distribution through the entire wall thickness of the pressure-retaining member. Gross-discontinuity type stresses are those portions of the actual stress distributions that produce net bending and membrane force resultants when integrated through the wall thickness. Examples of a gross structural discontinuity are head-to-shell junctions, flange-to-shell junctions, nozzles, and junctions between shells of different diameters or thicknesses.

NE-3213.3 Local Structural Discontinuity. Local structural discontinuity is a geometric or material discontinuity that affects the stress or strain distribution through a fractional part of the wall thickness. The stress distribution associated with a local discontinuity causes only very localized deformation or strain and has no significant effect on the shell-type discontinuity deformations. Examples are small fillet radii, small attachments, and partial penetration welds.

NE-3213.4 Normal Stress. Normal stress is the component of stress normal to the plane of reference. This is also referred to as direct stress. Usually the distribution of normal stress is not uniform through the thickness of a part, so this stress is considered to have two components, one uniformly distributed and equal to the average stress across the thickness under consideration, and the other varying from this average value across the thickness.

NE-3213.5 Shear Stress. Shear stress is the component of stress tangent to the plane of reference.

NE-3213.6 Membrane Stress. Membrane stress is the component of normal stress that is uniformly distributed and equal to the average stress across the thickness of the section under consideration.

NE-3213.7 Bending Stress. Bending stress is the component of normal stress that varies across the thickness. The variation may or may not be linear.

NE-3213.8 Primary Stress. Primary stress is any normal stress or shear stress developed by an imposed loading that is necessary to satisfy the laws of equilibrium of external and internal forces and moments. The basic characteristic of a primary stress is that it is not self-limiting. Primary stresses that considerably exceed the yield strength will result in failure or, at least, in gross distortion. Primary membrane stress is divided into general and local categories. A general primary membrane stress is one that is so distributed in the structure that no redistribution of load occurs as a result of yielding. Examples of primary stress are:

(a) general membrane stress in a circular cylindrical shell or a spherical shell due to internal pressure or to distributed loads;

(b) bending stress in the central portion of a flat head due to pressure.

Refer to [Table NE-3217-1](#) for examples of primary stress.

NE-3213.9 Secondary Stress. Secondary stress is a normal stress or a shear stress developed by the constraint of adjacent material or by self-constraint of the structure. The basic characteristic of a secondary stress is that it is self-limiting. Local yielding and minor distortions can satisfy the conditions that cause the stress to occur, and failure from one application of the stress is not to be expected. Examples of secondary stress are:

(a) general thermal stress [[NE-3213.13\(a\)](#)];

(b) bending stress at a gross structural discontinuity.

Refer to [Table NE-3217-1](#) for examples of secondary stress.

NE-3213.10 Local Primary Membrane Stress. Cases arise in which a membrane stress produced by pressure or other mechanical loading and associated with a discontinuity would, if not limited, produce excessive distortion in the transfer of load to other portions of the structure. Conservatism requires that such a stress be classified as a local primary membrane stress even though it has some characteristics of a secondary stress.

A stressed region may be considered local if the distance over which the membrane stress intensity exceeds $1.1S_{mc}$ does not extend in the meridional direction more than $1.0\sqrt{Rt}$, where R is the minimum midsurface radius of curvature and t is the minimum thickness in the region considered. Regions of local primary stress intensity involving axisymmetric membrane stress distributions that exceed $1.1S_{mc}$ shall not be closer in the meridional direction than $2.5\sqrt{R_L t_L}$, where R_L is defined as $(R_1 + R_2)/2$ and t_L is defined as $(t_1 + t_2)/2$ (where t_1 and t_2 are the minimum thicknesses at each of the regions considered, and R_1 and R_2 are the minimum midsurface radii of curvature at these regions where the membrane stress intensity exceeds $1.1S_{mc}$). Discrete regions of local primary membrane stress intensity, such as those resulting from concentrated loads acting on brackets, where the membrane stress intensity exceeds $1.1S_{mc}$, shall be spaced so that there is no overlapping of the areas in which the membrane stress intensity exceeds $1.1S_{mc}$. Examples of local primary membrane stress include

(a) membrane stress in a shell produced locally by an external load

(b) membrane stress in a shell at a permanent support or nozzle connection

(c) circumferential membrane stress at the intersection of a cylindrical shell with a conical shell due to internal pressure, as illustrated in [Figure NE-3213.10-1](#)

Figure NE-3213.10-1
Example of Acceptable Local Primary Membrane Stress Due to Pressure

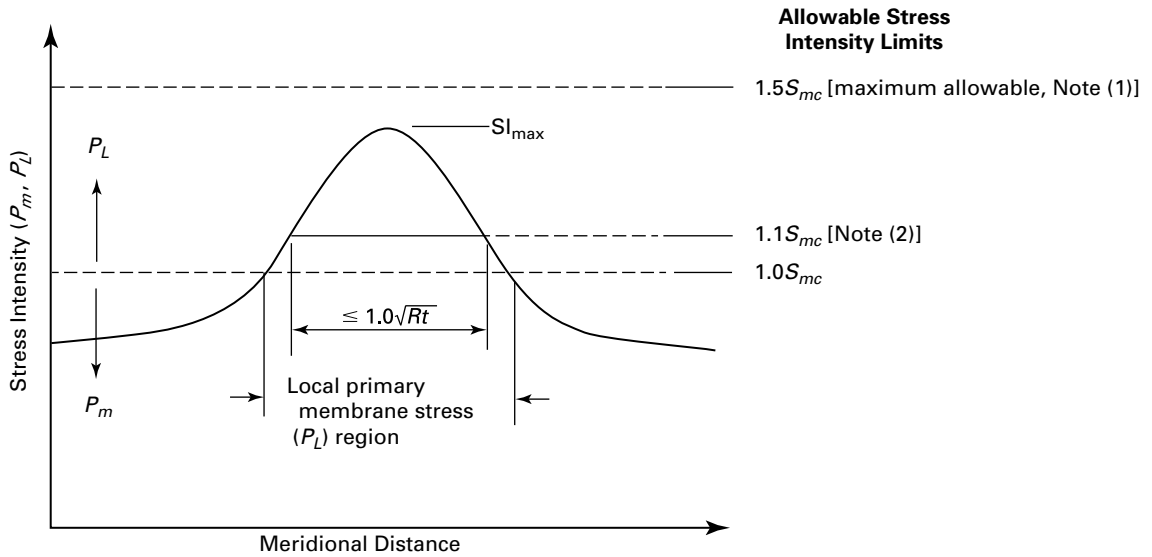
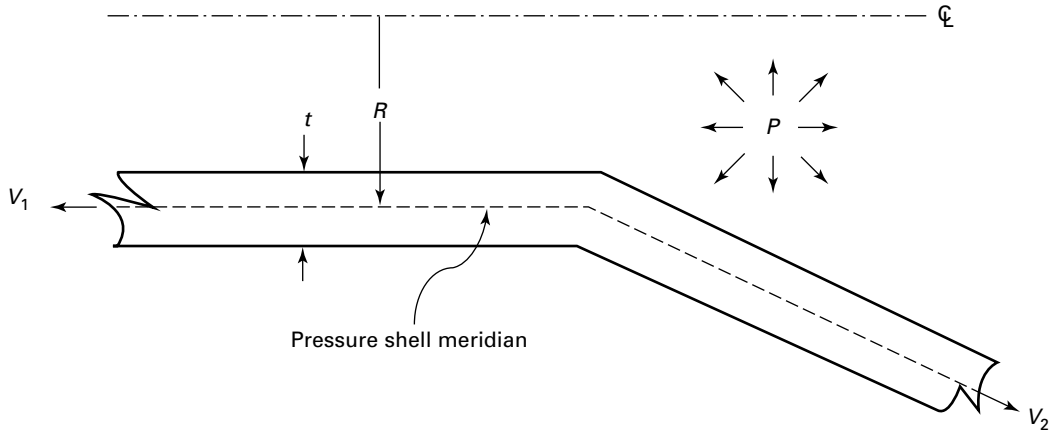

Legend:

- P = pressure
- P_L = primary local membrane stress intensity limit applies within local region
- P_m = primary general membrane stress intensity limit applies outside the local region
- R = minimum midsurface radius curvature
- S_{mc} = allowable stress intensity for the material at service temperature, see [NE-3112.4](#)
- SI_{max} = maximum stress intensity
- t = minimum thickness in stressed region considered
- V_1 and V_2 = meridional forces

NOTES:

- (1) See [NE-3221.2](#) for limits.
- (2) See [NE-3213.10](#) for limits.

NE-3213.11 Peak Stress. Peak stress is that increment of stress that is additive to the primary plus secondary stresses by reason of local discontinuities or local thermal stress [NE-3213.13(b)] including the effects, if any, of stress concentrations. The basic characteristic of a peak stress is that it does not cause any noticeable distortion and is objectionable only as a possible source of a fatigue crack or a brittle fracture. A stress that is not highly localized falls into this category if it is of a type that cannot cause noticeable distortion. Examples of peak stress are:

- (a) the thermal stress in the austenitic steel cladding of a carbon steel part;
- (b) certain thermal stresses that may cause fatigue but not distortion;
- (c) the stress at a local structural discontinuity;
- (d) surface stresses produced by thermal shock.

NE-3213.12 Load-Controlled Stress. Load-controlled stress is the stress resulting from application of a loading, such as internal pressure, inertial loads, or gravity, whose magnitude is not reduced as a result of displacement.

NE-3213.13 Thermal Stress. Thermal stress is a self-balancing stress produced by a nonuniform distribution of temperature or by differing thermal coefficients of expansion. Thermal stress is developed in a solid body whenever a volume of material is prevented from assuming the size and shape that it normally would under a change in temperature. For the purpose of establishing allowable stresses, two types of thermal stress are recognized, depending on the volume or area in which distortion takes place, as described in (a) and (b) below.

(a) General thermal stress is associated with distortion of the structure in which it occurs. If a stress of this type, neglecting stress concentrations, exceeds twice the yield strength of the material, the elastic analysis may be invalid, and successive thermal cycles may produce incremental distortion. Therefore, this type is classified as secondary stress in Table NE-3217-1. Examples of general thermal stress are:

- (1) stress produced by an axial temperature distribution in a cylindrical shell;
- (2) stress produced by the temperature difference between a nozzle and the shell to which it is attached;
- (3) the equivalent linear stress produced by the radial temperature distribution in a cylindrical shell. Equivalent linear stress is defined as the linear stress distribution that has the same net bending moment as the actual stress distribution.

(b) Local thermal stress is associated with almost complete suppression of the differential expansion and thus produces no significant distortion. Such stresses shall be considered only from the fatigue standpoint and are therefore classified as peak stresses in Table NE-3217-1. In evaluating local thermal stresses,

the procedures of NE-3227.6(b) shall be used. Examples of local thermal stress are:

- (1) the stress in a small hot spot in a vessel wall;
- (2) the difference between the actual stress and the equivalent linear stress [(a)(3)] resulting from a radial temperature distribution in a cylindrical shell;
- (3) the thermal stress in a cladding material that has a coefficient of expansion different from that of the base metal.

NE-3213.14 Total Stress. Total stress is the sum of the primary, secondary, and peak stress contributions. Recognition of each of the individual contributions is essential to establishment of appropriate stress limitations.

NE-3213.15 Service Cycle. Service cycle is defined as the initiation and establishment of new conditions followed by a return to the conditions that prevailed at the beginning of the cycle. The types of service conditions that may occur are further defined in NE-3113.

NE-3213.16 Stress Cycle. Stress cycle is a condition in which the alternating stress difference (NE-3221.5) goes from an initial value through an algebraic maximum value and an algebraic minimum value and then returns to the initial value. A single service cycle may result in one or more stress cycles. Dynamic effects shall also be considered as stress cycles.

NE-3213.17 Fatigue Strength Reduction Factor. Fatigue strength reduction factor is a stress intensification factor which accounts for the effect of a local structural discontinuity (stress concentration) on the fatigue strength. Values for some specific cases, based on experiment, are given in NE-3338. In the absence of experimental data, the theoretical stress concentration factor may be used.

NE-3213.18 Shakedown. Shakedown is the absence of a continuing cycle of plastic deformation. A structure shakes down if, after a few cycles of load application, the deformation stabilizes and subsequent structural response is elastic, excluding creep effects.

NE-3213.19 Free End Displacement. Free end displacement consists of the relative motions that would occur between a fixed attachment and connected piping if the two members were separated and permitted to move.

NE-3213.20 Expansion Stresses. Expansion stresses are those stresses resulting from restraint of free end displacement of the piping system.

NE-3213.21 Limit Analysis — Collapse Load. The methods of limit analysis are used to compute the maximum load or combination of loads a structure made of ideally plastic (nonstrain-hardening) material can carry. The deformations of an ideally plastic structure increase without bound at this load, which is termed the *collapse load*. Among the methods used in limit analysis is a

technique which assumes elastic, perfectly plastic, material behavior and a constant level of moment or force in those redundant structural elements in which membrane yield, plastic hinge, or critical buckling load has been reached. Any increase in load must be accompanied by a stable primary structure until a failure mechanism defined by the lower bound theorem of limit analysis is reached in the primary structure.

NE-3213.22 Collapse Load — Lower Bound. If, for a given load, any system of stresses can be found which everywhere satisfies equilibrium and nowhere exceeds the material yield strength, the load is at or below the collapse load. This is the lower bound theorem of limit analysis which permits calculations of a lower bound to the collapse load.

NE-3214 Stress Analysis

When required by [NE-3130](#), a detailed stress analysis of all major structural components shall be prepared in sufficient detail to show that each of the stress limitations of [NE-3220](#) and [NE-3230](#) is satisfied when the vessel is subjected to the loadings of [NE-3110](#). As an aid to the evaluation of these stresses, equations and methods for the solution of certain recurring problems have been placed in Section III Appendices, Nonmandatory Appendix A.

NE-3215 Derivation of Stress Intensities

One requirement for the acceptability of a design ([NE-3210](#)) is that the calculated stress intensities shall not exceed specified allowable limits. These limits differ depending on the stress category (primary, secondary, etc.) from which the stress intensity is derived. This paragraph describes the procedure for the calculation of the stress intensities which are subject to the specified limits. The steps in the procedure are stipulated in (a) through (e) below.

(a) At the point on the component which is being investigated, choose an orthogonal set of coordinates such as tangential, longitudinal, and radial, and designate them by the subscripts t , l , and r . The stress components in these directions are then designated σ_t , σ_l , and σ_r for direct stresses and τ_{lt} , τ_{lr} , and τ_{rt} for shear stresses.

(b) Calculate the stress components for each type of loading to which the part will be subjected and assign each set of stress values to one or a group of the following categories [see [Table NE-3217-1](#) and [Figure NE-3221-1](#), Note (1)]:

- (1) general primary membrane stress P_m ([NE-3213.8](#))
- (2) local primary membrane stress P_L ([NE-3213.10](#))
- (3) primary bending stress P_b ([NE-3213.7](#) and [NE-3213.8](#))
- (4) expansion stress P_e ([NE-3213.20](#))

(c) For each category, calculate the algebraic sum of the values of σ_t which result from the different types of loadings and similarly for the other five stress components. Certain combinations of the categories must also be considered.

(d) Translate the stress components for the t , l , and r directions into principal stresses σ_1 , σ_2 , and σ_3 . In many pressure component calculations, the t , l , and r directions may be so chosen that the shear stress components are zero and σ_1 , σ_2 , and σ_3 are identical to σ_t , σ_l , and σ_r .

(e) Calculate the stress differences S_{12} , S_{23} , and S_{31} from the relations:

$$S_{12} = \sigma_1 - \sigma_2$$

$$S_{23} = \sigma_2 - \sigma_3$$

$$S_{31} = \sigma_3 - \sigma_1$$

The stress intensity is the largest absolute value of S_{12} , S_{23} , and S_{31} .

NOTE: Membrane stress intensity is derived from the stress components averaged across the thickness of the section. The averaging shall be performed at the component level, in (b) or (c) above.

NE-3216 Derivation of Stress Differences

If the specified operation of the component does not meet the conditions of [NE-3221.5\(d\)](#), the ability of the component to withstand the specified cyclic service without fatigue failure shall be determined as provided in [NE-3221.5\(e\)](#). The determination shall be made on the basis of the stresses at the point of the component, and the allowable stress cycles shall be adequate for the specified service at every point. Only the stress differences due to cyclic Service Loadings as specified in the Design Specifications need be considered.

NE-3216.1 Constant Principal Stress Direction. For any case in which the directions of the principal stresses at the point being considered do not change during the cycle, the steps stipulated in (a), (b), and (c) below shall be taken to determine the alternating stress intensity.

(a) *Principal Stresses.* Consider the values of the three principal stresses at the point versus time for the complete stress cycle, taking into account both the gross and local structural discontinuities and the thermal effects which vary during the cycle. These are designated as σ_1 , σ_2 , and σ_3 for later identification.

(b) *Stress Differences.* Determine the stress differences $S_{12} = \sigma_1 - \sigma_2$, $S_{23} = \sigma_2 - \sigma_3$, $S_{31} = \sigma_3 - \sigma_1$ versus time for the complete cycle. In what follows, the symbol S_{ij} is used to represent any one of these three stress differences.

(c) *Alternating Stress Intensity.* Determine the extremes of the range through which each stress difference S_{ij} fluctuates and find the absolute magnitude of this range for each S_{ij} . Call this magnitude S_{rij} and let $S_{altij} = 0.5 S_{rij}$. The alternating stress intensity S_{alt} is the largest S_{altij} .

NE-3216.2 Varying Principal Stress Direction. For any case in which the directions of the principal stresses at the point being considered do change during the stress cycle, it is necessary to use the more general procedure of (a) through (e) below.

(a) Consider the values of the six stress components σ_t , σ_l , σ_r , τ_{lt} , τ_{lr} , τ_{rt} versus time for the complete stress cycle, taking into account both the gross and local structural discontinuities and the thermal effects which vary during the cycle.

(b) Choose a point in time when the conditions are one of the extremes for the cycle (either maximum or minimum, algebraically) and identify the stress components at this time by the subscript i . In most cases it will be possible to choose at least one time during the cycle when the conditions are known to be extreme. In some cases it may be necessary to try different points in time to find the one which results in the largest value of alternating stress intensity.

(c) Subtract each of the six stress components σ_{ti} , σ_{li} , etc., from the corresponding stress components σ_t , σ_l , etc., at each point in time during the cycle and call the resulting components σ'_t , σ'_l , etc.

(d) At each point in time during the cycle, calculate the principal stresses σ'_1 , σ'_2 , σ'_3 derived from the six stress components σ'_t , σ'_l , etc. Note that the directions of the principal stresses may change during the cycle but each principal stress retains its identity as it rotates.

(e) Determine the stress differences $S'_{12} = \sigma'_1 - \sigma'_2$, $S'_{23} = \sigma'_2 - \sigma'_3$, $S'_{31} = \sigma'_3 - \sigma'_1$ versus time for the complete cycle and find the largest absolute magnitude of any stress difference at any time. The alternating stress intensity S_{alt} is one-half of this magnitude.

NE-3217 Classification of Stresses

Table NE-3217-1 provides assistance in the determination of the category to which a stress should be assigned.

NE-3220 STRESS INTENSITY AND BUCKLING STRESS VALUES FOR OTHER THAN BOLTS

NE-3221 Stress Intensity Values

(a) The stress intensity values for materials of Class MC components are as established in NE-3112.4(a). The materials shall not be used at temperatures above those for which stress intensity values are given. The values in the tables may be interpolated for intermediate temperatures.

(b) The stress intensity limits which must be satisfied for the Design and Service Loadings stated in the Design Specifications are the limits of this paragraph and the Special Stress Limits of NE-3227. The provisions of NE-3228 may provide relief from certain of these stress limits if plastic analysis techniques are applied. The stress intensity limits are summarized in Table NE-3221-1 and Figures NE-3221-1, NE-3221-2, NE-3221-3, and NE-3221-4.

NE-3221.1 General Primary Membrane Stress Intensity. (Derived from P_m in Figures NE-3221-1, NE-3221-2, NE-3221-3, and NE-3221-4.) This stress intensity is derived from the average value across the thickness of a section of the general primary stresses (NE-3213.8), produced by pressure and other specified mechanical loads but excluding all secondary and peak stresses. Averaging is to be applied to the stress components prior to determination of the stress intensity values. The allowable Design Limit and the allowable for each of the Service Limits is as given below.

(a) *Design Limit and Level A and B Service Limits.* P_m shall not exceed $1.0S_{mc}$.

(b) *Level C Service Limits*

(1) P_m shall not exceed the greater of $1.2S_{mc}$ or $1.0S_y$ for regions of the vessel which are integral and continuous.

(2) P_m shall not exceed $1.0S_{mc}$ for regions of the vessel that are not integral and continuous, such as bolted flanges and mechanical joints.

(c) *Level D Service Limits*

(1) P_m shall not exceed the greater of the following two values for regions of the containment which are integral and continuous.

(-a) 85% of the value permitted in Section III Appendices, Mandatory Appendix XXVII. In the application of the rules of Section III Appendices, Mandatory Appendix XXVII, S_m , if applicable, shall be as specified in NE-3112.4(a)(1).

(-b) The value established in (b)(1) for Service Level C limits.

(2) P_m shall not exceed the greater of $1.2S_{mc}$ or $1.0S_y$ for regions of the vessel that are not integral and continuous and at partial penetration welds.

NE-3221.2 Local Membrane Stress Intensity. (Derived from P_L in Figures NE-3221-1, NE-3221-2, NE-3221-3, and NE-3221-4.) This stress intensity is derived from the average value across the thickness of a section of the local primary stresses (NE-3213.10) produced by pressure and specified mechanical loads, but excluding all secondary and peak stresses. Averaging is to be applied to the stress components prior to determination of the stress intensity values. The allowable value of this stress intensity is 1.5 times the values given in NE-3221.1, except that the 1.5 factor is not permitted for Level D Service Limits when inelastic component analysis is

Table NE-3217-1
Classification of Stress Intensity in Vessels for Some Typical Cases

Vessel Component	Location	Origin of Stress	Type of Stress	Classification
Cylindrical or spherical shell	Shell plate remote from discontinuities	Internal pressure	General membrane	P_m
			Gradient through plate thickness	Q
		Axial thermal gradient	Membrane	Q
			Bending	Q
	Junction with head or flange	Internal pressure	Membrane	P_L
			Bending	Q [Note (1)]
Any shell or head	Any section across entire vessel	External load or moment, or internal pressure	General membrane averaged across full section	P_m
			Bending across full section	P_m
	Near nozzle or other opening	External load or moment, or internal pressure	Local membrane	P_L
			Bending	Q
			Peak (fillet or corner)	F
	Any location	Temperature difference between shell and head	Membrane	Q
			Bending	Q
	Dished head or conical head	Crown	Internal pressure	Membrane
Bending				P_b
Knuckle or junction to shell		Internal pressure	Membrane	P_L [Note (2)]
			Bending	Q
Flat head	Center region	Internal pressure	Membrane	P_m
			Bending	P_b
	Junction to shell	Internal pressure	Membrane	P_L
			Bending	Q [Note (1)]
Perforated head or shell	Typical ligament in a uniform pattern	Pressure	Membrane (through cross section)	P_m
			Bending (through width of ligament, but gradient through plate)	P_b
			Peak	F
	Isolated or atypical ligament	Pressure	Membrane	Q
			Bending	F
			Peak	F

Table NE-3217-1
Classification of Stress Intensity in Vessels for Some Typical Cases (Cont'd)

Vessel Component	Location	Origin of Stress	Type of Stress	Classification	
Nozzle (NE-3227.5)	Within the limits of reinforcement defined by NE-3334	Pressure and external loads and moments, including those attributable to restrained free end displacements of attached piping	General membrane	P_m	
			Bending (other than gross structural discontinuity stresses) averaged through nozzle thickness	P_m	
	Outside the limits of reinforcement defined by NE-3334	Pressure and external axial, shear, and torsional loads other than those attributable to restrained free end displacements of the attached piping	General membrane stresses		P_m
			Pressure and external loads and moments other than those attributable to restrained free end displacements of the attached piping	Membrane	P_L
				Bending	P_b
			Pressure, and all external loads and moments	Membrane	P_L
				Bending	Q
		Peak	F		
	Nozzle wall	Gross structural discontinuities	Local membrane	P_L	
			Bending	Q	
			Peak	F	
		Differential expansion	Membrane	Q	
Bending			Q		
Peak			F		
Cladding	Any	Differential expansion	Membrane	F	
			Bending	F	
Any	Any	Radial temperature distribution [Note (3)]	Equivalent linear stress [NE-3213.13(a)(3)]	Q	
			Nonlinear portion of stress distribution	F	
		Any	Stress concentration (notch effect)	F	

GENERAL NOTE: Q and F classifications of stresses refer to other than design condition (Figure NE-3221-2).

NOTES:

- (1) If the bending moment at the edge is required to maintain the bending stress in the middle to within acceptable limits, the edge bending is classified as P_b . Otherwise, it is classified as Q .
- (2) Consideration must also be given to the possibility of wrinkling and excessive deformation in vessels with a large diameter–thickness ratio.
- (3) Consider possibility of thermal stress ratchet.

used as permitted in Section III Appendices, Mandatory Appendix XXVII.

NE-3221.3 Primary General or Local Membrane Plus Primary Bending Stress Intensity. (Derived from $P_L + P_b$ in Figures NE-3221-1, NE-3221-2, NE-3221-3, and NE-3221-4.) This stress intensity is derived from the highest value, across the thickness of a section, of the general or local primary membrane stress plus primary bending stresses produced by pressure and other loads but excluding all secondary and peak stresses. The allowable Design Limit and the allowable Service Limits are as given in (a) through (d) below.

(a) *Design Limit and Level A and B Service Limits.* For solid rectangular sections, 1.5 times the value given in NE-3221.1.

(b) *Level C Service Limits*

(1) For solid rectangular sections where the structure is integral and continuous, 1.5 times the value given in NE-3221.1.

(2) For solid rectangular sections when the structure is not integral and continuous, 1.5 times the value given in NE-3221.1.

(c) *Level D Service Limits*

(1) When elastic analysis is used for solid rectangular sections where the structure is integral and continuous, 1.5 times the value given in NE-3221.1.

(2) When elastic analysis is used for solid rectangular sections where the structure is not integral and continuous, 1.5 times the value given in NE-3221.1.

(3) When inelastic component analysis is used, this Service Limit shall be 85% of the value permitted in Section III Appendices, Mandatory Appendix XXVII.

(d) For other than solid rectangular sections, a value of α times the limit established in NE-3221.1 may be used, where the factor α is defined as the ratio of the load set producing a fully plastic section divided by the load set producing initial yielding in the extreme fibers of the section. In the evaluation of the initial yield and fully plastic section capacities, the ratios of each individual load in the respective load set to each other load in that load set shall be the same as the respective ratios of the individual loads in the specified design load set. The value of α shall not exceed the value calculated for bending only ($P_m = 0$). In no case shall the value of α exceed 1.5. The propensity for buckling of the part of the section that is in compression shall be investigated. The α factor is not permitted for Level D Service Limits when inelastic component analysis is used as permitted in Section III Appendices, Mandatory Appendix XXVII.

NE-3221.4 Primary Plus Secondary Stress Intensity. This stress intensity is derived from the highest value, at any point across the thickness of a section, of the general or local primary membrane stresses, plus

primary bending stresses plus secondary stresses, produced by the specified conditions. The allowable value of the maximum range of this stress intensity is $3.0S_m$ for Level A and B Service Limits. Secondary stresses need not be evaluated for Design Loadings or for Level C and D Service Limits.

The concept of stress differences discussed in NE-3216 is essential to determination of the maximum range, since algebraic signs must be retained in the computation. Note that this limitation on range is applicable to the entire history of service conditions, not just to the stresses resulting from each individual service condition.

NE-3221.5 Analysis for Cyclic Operation.

(a) *Suitability for Cyclic Condition.* The suitability of a vessel or part for specified Service Loadings involving cyclic application of loads and thermal conditions shall be determined by the methods described herein, except that the suitability of high strength bolts shall be determined by the methods of NE-3232.3(b) and the possibility of thermal stress ratchet shall be investigated in accordance with NE-3221.6. If the specified Service Loadings for the component meet all of the requirements of (d), no analysis for cyclic service is required, and it may be assumed that the limits on peak stress intensities as governed by fatigue have been satisfied by compliance with the applicable requirements for materials, design, fabrication, examination, and testing of this Subsection. If the specified Service Loadings do not meet all the conditions of (d), a fatigue analysis shall be made in accordance with (e) or a fatigue test shall be made in accordance with Section III Appendices, Mandatory Appendix II, II-1200.

(b) *Peak Stress Intensity.* This stress intensity is derived from the highest value at any point across the thickness of a section of the combination of all primary, secondary, and peak stresses produced by specified service pressures and other mechanical loads, and by general and local thermal effects associated with Service Conditions, and including the effects of gross and local structural discontinuities.

(c) *Conditions and Procedures.* The conditions and procedures of (e) are based on a comparison of peak stress intensities with strain cycling fatigue data. The strain cycling fatigue data are represented by design fatigue strength curves of Section III Appendices, Mandatory Appendix I. These curves show the allowable amplitude S_a of the alternating stress intensity component (one-half of the alternating stress intensity range) plotted against the number of cycles. This stress intensity amplitude is calculated on the assumption of elastic behavior and, hence, has the dimensions of stress, but it does not represent a real stress when the elastic range is exceeded. The fatigue curves are obtained from uniaxial strain cycling data in which the imposed strains have been multiplied by the elastic modulus and a design margin has been provided so as to make the calculated stress intensity

Table NE-3221-1
Summary of Stress Intensity Limits

Loading Condition						
Symbol	Design Stress Intensity Limit	Level A Service Stress Intensity Limit	Level B Service Stress Intensity Limit and Level C Service Stress Limit Where the Structure Is Not Integral and Continuous	Level C Service Stress Intensity Limit Where the Structure Is Integral and Continuous, and Level D Service Stress Limit Where the Structure Is Not Integral and Continuous, and at Partial Penetration Welds [Note (1)]	Level D Service Stress Intensity Limit Where the Structure Is Integral and Continuous (Elastic Analysis) [Note (2)]	Level D Service Stress Intensity Limit Where the Structure Is Integral and Continuous (Inelastic Analysis) [Note (2)]
P_m	$1.0S_{mc}$	$1.0S_{mc}$	$1.0S_{mc}$	$1.2S_{mc}$ or * $1.0S_y$	S_f	S_f
P_L	$1.5S_{mc}$	$1.5S_{mc}$	$1.5S_{mc}$	$1.8S_{mc}$ or * $1.5S_y$	$1.5S_f$	S_f
$P_L + P_b$ [Note (3)]	$1.5S_{mc}$	$1.5S_{mc}$	$1.5S_{mc}$	$1.8S_{mc}$ or * $1.5S_y$	$1.5S_f$	S_f
$P_L + P_b + Q$	N/A [Note (4)]	$3.0S_m$	$3.0S_m$ [Note (5)]	N/A [Note (4)]	N/A [Note (4)]	N/A [Note (4)]
$P_L + P_b + Q + F$	N/A [Note (4)]	S_a	S_a [Note (5)]	N/A [Note (4)]	N/A [Note (4)]	N/A [Note (4)]

NOTES:

- (1) Limits identified by (*) indicate a choice of the larger of two limits.
- (2) S_f is 85% of the general primary membrane allowable permitted in Section III Appendices, Mandatory Appendix XXVII. In the application of the rules of Section III Appendices, Mandatory Appendix XXVII, S_m , if applicable, shall be as specified in NE-3112.4(a)(1).
- (3) Values shown are for a solid rectangular section. See NE-3221.3(d) for other than a solid rectangular section.
- (4) N/A — No evaluation required.
- (5) Evaluation not required for Level C Service.

Figure NE-3221-1
Stress Categories and Limits of Stress Intensity for Design Conditions

Stress Category	Primary		
	General Membrane	Local Membrane	Bending
Description (Table NE-3217-1)	Average primary stress across solid section. Excludes discontinuities and concentrations.	Average stress across any solid section. Considers discontinuities but not concentrations.	Component of primary stress proportional to distance from centroid of solid section. Excludes discontinuities and concentrations.
Symbol [Note (1)]	P_m	P_L	P_b
Combination Stress Components and Allowable Limits of Stress Intensities			
Legend	<p>○ Allowable value</p> <p>□ Calculated value</p> <p>—— Use Design Loads</p>		
	<p style="text-align: right;">$P_L + P_b$ — $1.5 S_{mc}$ [Note (2)]</p>		

NOTES:

- (1) The symbols P_m , P_L , and P_b do not represent single quantities, but rather sets of six quantities representing the six stress components σ_b , σ_l , σ_r , τ_{lb} , τ_{lr} , and τ_{rt} .
- (2) Value shown is for a solid rectangular section. See NE-3221.3(d) for other than a solid rectangular section.

Figure NE-3221-2
Stress Categories and Limits of Stress Intensity for Level A and B Service Limits;
and for Level C Service Limits Where the Structure Is Not Integral and Continuous

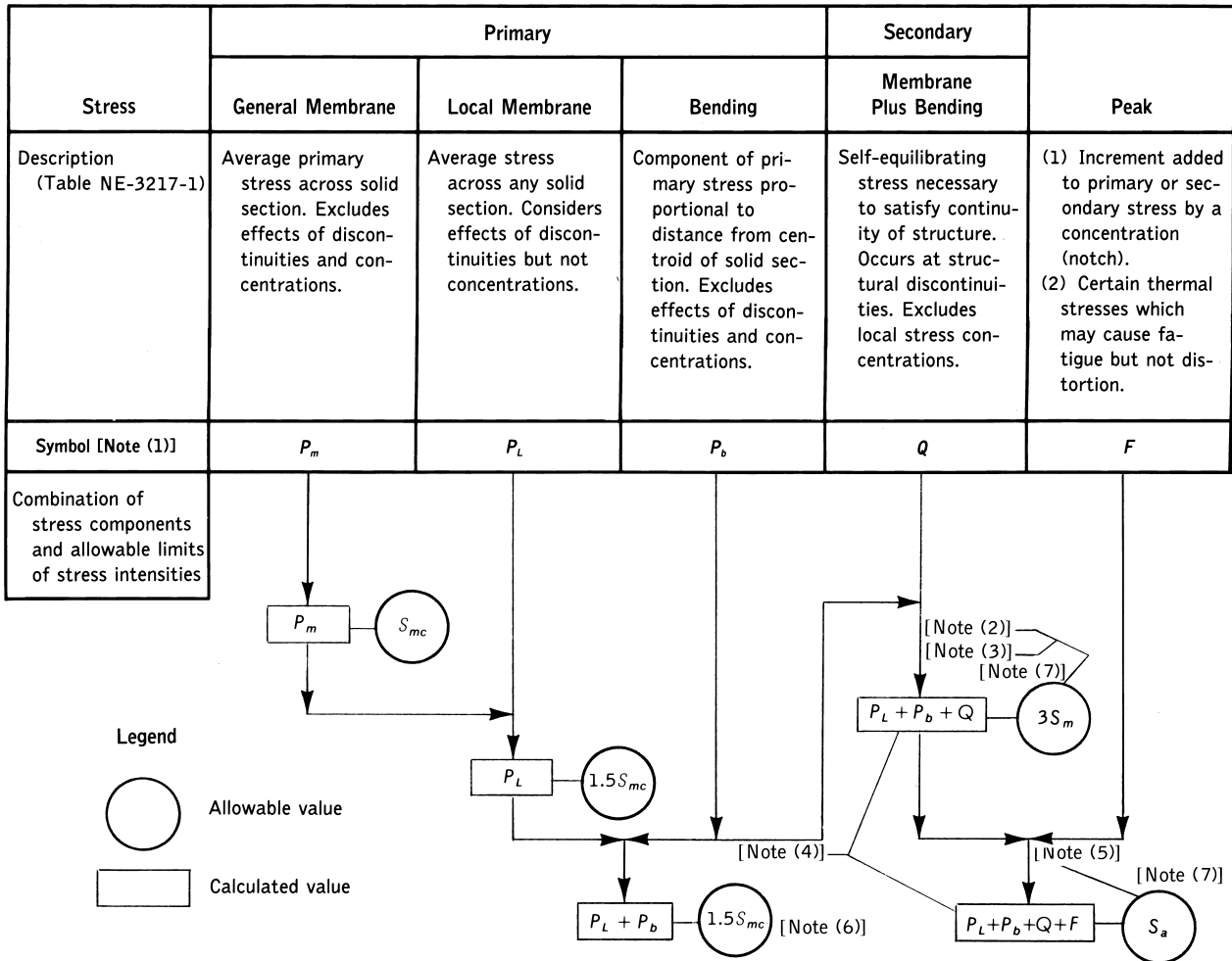

NOTES:

- (1) The symbols P_m , P_L , Q , and F do not represent single quantities, but sets of six quantities representing the six stress components σ_b , σ_l , σ_r , τ_{lt} , τ_{lr} , and τ_{rt} .
- (2) When the secondary stress is due to a temperature transient at the point at which the stresses are being analyzed, the value of S_m shall be taken as the average of the tabulated S_m values for the highest and the lowest temperatures of the metal during the transient. When part or all of the secondary stress is due to mechanical load, the value of S_m shall not exceed the value for the highest temperature of metal during the transient.
- (3) Special rules for exceeding $3S_m$ are provided in [NE-3228.3](#).
- (4) The stresses in category Q are those parts of the total stress that are produced by thermal gradients, structural discontinuities, and they do not include the primary stresses that may also exist at the same point. However, it should be noted that a detailed stress analysis frequently gives the combination of primary and secondary stresses directly and, when appropriate, the calculated value represents the total of $P_m + P_b + Q$ and not Q alone. Similarly, if the stress in category F is produced by a stress concentration, the quantity F is the additional stress produced by the notch over and above the nominal stress. For example, if a point has a nominal stress intensity P_m and has a notch with a stress concentration factor K , then $P_m \leq S_{mc}$, $P_b = Q$, $Q = 0$, $F = P_m(K - 1)$, and the peak stress intensity effects, rather a stress increment. Therefore, the P_L value always includes the P_m contribution.
- (5) S_a is obtained from the fatigue curves, Section III Appendices, Mandatory Appendix I. The allowable stress intensity for the full range of fluctuation is $2S_a$.
- (6) Value shown is for a solid rectangular section. See [NE-3221.3\(d\)](#) for other than a solid rectangular section.
- (7) Evaluation not required for Level C Service limits.

Figure NE-3221-3
Stress Categories and Limits of Stress Intensity for Level C Service Limits Where the Structure Is Integral and Continuous; and for Level D Service Limits Where the Structure Is Not Integral and Continuous, and at Partial Penetration Welds

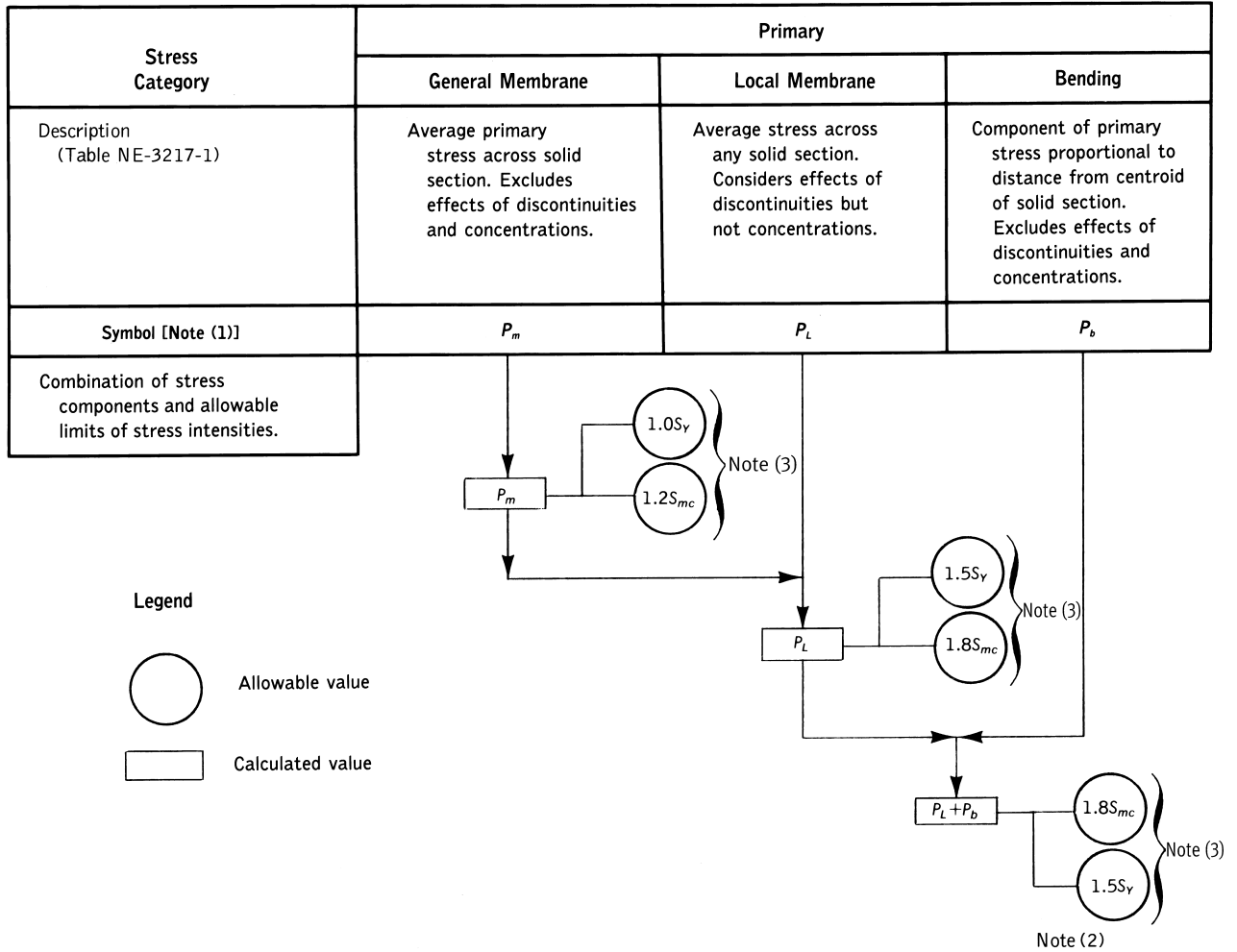

NOTES:

- (1) The symbols P_m , P_L , and P_b do not represent single quantities, but sets of six representing the six stress components σ_b , σ_d , σ_r , τ_{lb} , τ_{lr} , τ_{rt} .
- (2) Values shown are for a solid rectangular section. See NE-3221.3(d) for other than a solid rectangular section.
- (3) Use greater of values specified.

Figure NE-3221-4
Stress Categories and Limits of Stress Intensity for Level D Service Limits Where the Structure Is Integral and Continuous

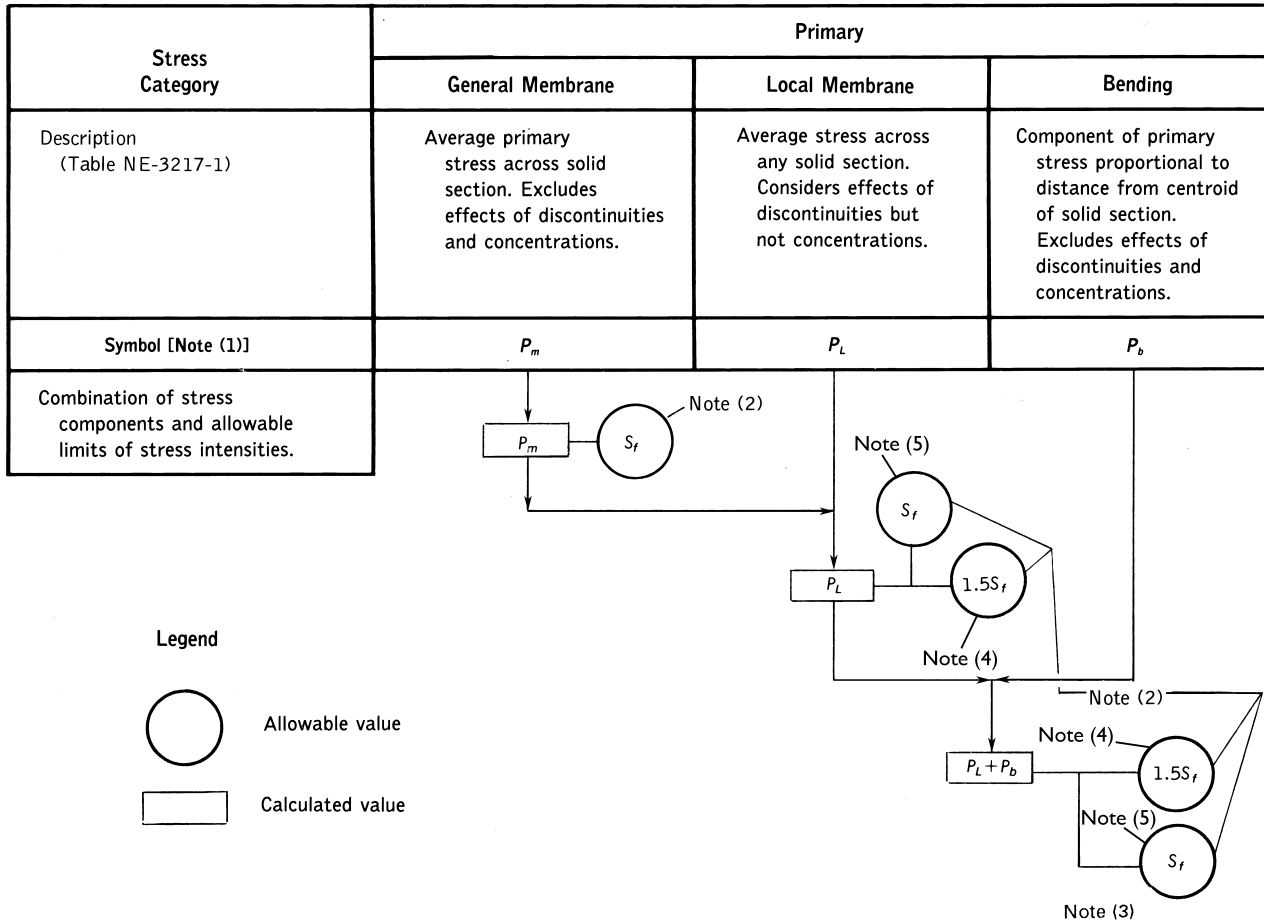

NOTES:

- (1) The symbols P_m , P_L , and P_b do not represent single quantities, but sets of six quantities representing the six stress components σ_b , σ_l , σ_r , τ_{lb} , τ_{lr} , τ_{rb} .
- (2) S_f is 85% of the general membrane allowable permitted in Section III Appendices, Mandatory Appendix XXVII. In the application of the rules of Section III Appendices, Mandatory Appendix XXVII, S_m , if applicable, shall be as specified in [NE-3112.4\(a\)\(1\)](#).
- (3) Values shown are for a solid rectangular section. See [NE-3221.3\(d\)](#) for other than a solid rectangular section.
- (4) Elastic analysis
- (5) Inelastic analysis

amplitude and the allowable stress intensity amplitude directly comparable. The curves have been adjusted, where necessary, to include the maximum effects of mean stress, which is the condition where the stress fluctuates about a mean value which is different from zero. As a consequence of this procedure, it is essential that the requirements of [NE-3221.4](#) be satisfied at all times with transient stresses included, and that the calculated value of the alternating stress intensity be proportional to the actual strain amplitude. To evaluate the effect of alternating stresses of varying amplitudes, a linear damage relation is assumed in [\(e\)\(5\)](#).

(d) Vessels Not Requiring Analysis for Cyclic Service. An analysis for cyclic service is not required, and it may be assumed that the limits on peak stress intensities as governed by fatigue have been satisfied for a vessel by compliance with the applicable requirements for construction in this Subsection, provided the specified Service Loadings of the vessel or portion thereof meet all the conditions stipulated in [\(1\)](#) through [\(6\)](#) below.

(1) Atmospheric-to-Service Pressure Cycle. The specified number of times (including startup and shutdown) that the pressure will be cycled from atmospheric pressure to service pressure and back to atmospheric pressure

during service does not exceed the number of cycles on the applicable fatigue curve of Section III Appendices, Mandatory Appendix I, corresponding to an S_a value of 3 times the S_m value for the material at service temperature.

(2) *Normal Service Pressure Fluctuation.* The specified full range of pressure fluctuations during service does not exceed the quantity $(\frac{1}{3}) \times \text{Design Pressure} \times (S_a/S_m)$ where S_a is the value obtained from the applicable design fatigue curve for the total specified number of significant pressure fluctuations and S_m is the allowable stress intensity for the material at service temperature. If the total specified number of significant pressure fluctuations exceeds the maximum number of cycles defined on the applicable design fatigue curve, the S_a value corresponding to the maximum number of cycles defined on the curve may be used. Significant pressure fluctuations are those for which the total excursion exceeds the quantity:

$$\text{Design Pressure} \times \frac{1}{3} \times \frac{S}{S_m}$$

where S is defined as follows:

(-a) if the total specified number of service cycles is 10^6 cycles or less, S is the value of S_a obtained from the applicable design fatigue curve for 10^6 cycles;

(-b) if the total specified number of service cycles exceeds 10^6 cycles, S is the value of S_a obtained from the applicable design fatigue curve for the maximum number of cycles defined on the curve.

(3) *Temperature Difference — Startup and Shutdown.* The temperature difference in $^{\circ}\text{F}$ ($^{\circ}\text{C}$) between any two adjacent points of the vessel during service does not exceed $S_a/(2E\alpha)$, where S_a is the value obtained from the applicable design fatigue curves in psi (MPa) for the specified number of startup-shutdown cycles, α is the value of the instantaneous coefficient of thermal expansion in $1/^{\circ}\text{F}$ ($1/^{\circ}\text{C}$) and E is the value of Young's Modulus at the mean value of the temperatures at the two points as given by Section II, Part D, Subpart 2, Tables TE and TM, psi (MPa). Adjacent points are defined as follows:

(-a) For surface temperature differences:

(-1) on surfaces of revolution in the meridional direction, adjacent points are defined as points that are spaced less than the distance $2\sqrt{Rt}$ where R is the radius measured normal to the surface from the axis of rotation to the mid-wall and t is the thickness of the part at the point under consideration. If the product of Rt varies, the average value of the points shall be used.

(-2) on surfaces of revolution in the circumferential direction, and on flat parts such as flanges and flat heads, adjacent points are defined as any two points on the same surface.

(-b) For through-thickness temperature differences, adjacent points are defined as any two points on a line normal to any surface.

(4) *Temperature Difference — Similar Material.* The temperature difference in $^{\circ}\text{F}$ ($^{\circ}\text{C}$) between any two adjacent points [(3)] does not change during normal service by more than the quantity $S_a/(2E\alpha)$, where S_a is the value obtained from the applicable design fatigue curve of Section III Appendices, Mandatory Appendix I for the total specified number of significant temperature difference fluctuations. A temperature difference fluctuation (considering the algebraic range of the difference) shall be considered to be significant if its total algebraic range exceeds the quantity $S/2(E\alpha)$, where S is defined as follows:

(-a) If the total specified number of service cycles is 10^6 cycles or less, S is the value of S_a obtained from the applicable design fatigue curve for 10^6 cycles.

(-b) If the total specified number of service cycles exceeds 10^6 cycles, S is the value of S_a obtained from the applicable design fatigue curve for the maximum number of cycles defined on the curve.

(5) *Temperature Difference — Dissimilar Materials.* For components fabricated from materials of differing moduli of elasticity or coefficients of thermal expansion, the total algebraic range of temperature fluctuation in $^{\circ}\text{F}$ ($^{\circ}\text{C}$) experienced by the component during service does not exceed the magnitude $S_a/2(E_1\alpha_1 - E_2\alpha_2)$, where S_a is the value obtained from the applicable design fatigue curve for the total specified number of significant temperature fluctuations in psi (MPa), E_1 and E_2 are the moduli of elasticity in psi (MPa), and α_1 and α_2 are the values of the instantaneous coefficients of thermal expansion at the mean temperature value involved for the two materials of construction (Section II, Part D, Subpart 2, Tables TE and TM), in $1/^{\circ}\text{F}$ ($1/^{\circ}\text{C}$). A temperature fluctuation shall be considered to be significant if its total excursion exceeds the quantity $S/2(E_1\alpha_1 - E_2\alpha_2)$, where S is defined as follows:

(-a) If the total specified number of service cycles is 10^6 cycles or less, S is the value of S_a obtained from the applicable design fatigue curve for 10^6 cycles.

(-b) If the total specified number of service cycles exceeds 10^6 cycles, S is the value of S_a obtained from the applicable design fatigue curve for the maximum number of cycles defined on the curve. If the two materials used have different applicable design fatigue curves, the lower value of S_a shall be used in applying the rules of this paragraph.

(6) *Mechanical Loads.* The specified full range of mechanical loads, excluding pressure but including pipe reactions, does not result in load stress intensities whose range exceeds the S_a value obtained from the applicable design fatigue curve of Section III Appendices, Mandatory Appendix I, for the total specified number of significant load fluctuations. If the total specified number of significant load fluctuations exceeds the maximum number of cycles defined on the applicable design fatigue curve, the S_a value corresponding to the

maximum number of cycles defined on the curve may be used. A load fluctuation shall be considered to be significant if the total excursion of load stress exceeds the quantity S , where S is defined as follows:

(-a) If the total specified number of service cycles is 10^6 cycles or less, S is the value of S_a obtained from the applicable design fatigue curve for 10^6 cycles.

(-b) If the total specified number of service cycles exceeds 10^6 cycles, S is the value of S_a obtained from the applicable design fatigue curve for the maximum number of cycles defined on the curve.

(e) *Procedure for Analysis for Cyclic Loading.* If the specified service loadings for the vessel do not meet the conditions of (d), the ability of the vessel to withstand the specified cyclic service without fatigue failure shall be determined as provided herein. The determination shall be made on the basis of the stresses at a point, and the allowable stress cycles shall be adequate for the specified service loadings at every point. Only the stress differences due to service cycles as specified in the Design Specifications need be considered. Compliance with these requirements means only that the component is suitable from the standpoint of possible fatigue failure; complete suitability for the specified Service Loadings is also dependent on meeting the general stress limits of NE-3221 and any applicable special stress limits of NE-3227.

(1) *Stress Differences.* For each condition of specified service, determine the stress differences and the alternating stress intensity S_{alt} in accordance with NE-3216.

(2) *Local Structural Discontinuities.* These effects shall be evaluated for all Service Loadings using stress concentration factors determined from theoretical, experimental, or photoelastic studies, or stress analysis techniques. Experimentally determined fatigue strength reduction factors may be used when determined in accordance with the procedures of Section III Appendices, Mandatory Appendix II, II-1600, except for high strength alloy steel bolting for which the requirements of NE-3232.3(c) shall apply when using the design fatigue curve of Section III Appendices, Mandatory Appendix I, Figure I-9.4. Except for the case of crack-like defects, no fatigue strength reduction factor greater than 5 need be used.

(3) *Design Fatigue Curves.* Section III Appendices, Mandatory Appendix I contains the applicable fatigue design curves for the materials permitted by this Subsection. When more than one curve is presented for a given material, the applicability of each curve to materials of various strength levels is identified. Linear interpolation may be used for intermediate strength levels of these materials. As used herein, the strength level is the specified minimum room temperature value.

(4) *Effect of Elastic Modulus.* Multiply S_{alt} (as determined in NE-3216.1 or NE-3216.2) by the ratio of the modulus of elasticity given on the design fatigue curve to the value of the modulus of elasticity used in the analysis. Enter the applicable design fatigue curve of

Section III Appendices, Mandatory Appendix I, at this value on the ordinate axis and find the corresponding number of cycles on the abscissa. If the service cycle being considered is the only one which produces significant fluctuating stresses, this is the allowable number of cycles.

(5) *Cumulative Damage.* If there are two or more types of stress cycles which produce significant stresses, their cumulative effect shall be evaluated as stipulated in Steps 1 through 6 below.

Step 1. Designate the specified number of times each type of stress cycle of types 1, 2, 3, ..., n will be repeated during the life of the component as $n_1, n_2, n_3, \dots, n_n$, respectively.

NOTE: In determining $n_1, n_2, n_3, \dots, n_n$, consideration shall be given to the superposition of cycles of various origins which produce a total stress difference range greater than the stress difference ranges of the individual cycles. For example, if one type of stress cycle produces 1000 cycles of a stress difference variation from zero to +60,000 psi and another type of stress cycle produces 10,000 cycles of a stress difference variation from zero to -50,000 psi, the two types of cycle to be considered are defined by the following parameters:

(a) Type 1 cycle: $n_1 = 1,000$,

$S_{alt1} = (60,000 + 50,000)/2 = 55,000$ psi

(b) Type 2 cycle: $n_2 = 9,000$,

$S_{alt2} = (50,000 + 0)/2 = 25,000$ psi

Step 2. For each type of stress cycle, determine the alternating stress intensity S_{alt} by the procedures of NE-3216.1 or NE-3216.2 above. Call these quantities $S_{alt1}, S_{alt2}, S_{alt3}, \dots, S_{altn}$.

Step 3. For each value $S_{alt1}, S_{alt2}, S_{alt3}, \dots, S_{altn}$, use the applicable design fatigue curve to determine the maximum number of repetitions which would be allowable if this type of cycle were the only one acting. Call these values $N_1, N_2, N_3, \dots, N_n$.

Step 4. For each type of stress cycle, calculate the usage factors $U_1, U_2, U_3, \dots, U_n$ from $U_1 = n_1/N_1, U_2 = n_2/N_2, U_3 = n_3/N_3, \dots, U_n = n_n/N_n$.

Step 5. Calculate the cumulative usage factor U from $U = U_1 + U_2 + U_3 + \dots + U_n$.

Step 6. The cumulative usage factor U shall not exceed 1.0.

NE-3221.6 Thermal Stress Ratchet. It should be noted that under certain combinations of steady state and cyclic loadings there is a possibility of large distortions developing as the result of ratchet action; that is, the deformation increases by a nearly equal amount for each cycle. Examples of this phenomenon are treated in this subparagraph and in NE-3227.3.

(a) The limiting value of the maximum cyclic thermal stress permitted in a portion of an axisymmetric shell loaded by steady state internal pressure in order to prevent cyclic growth in diameter is as follows. Let:

- x = maximum general membrane stress due to pressure divided by the yield strength S_y
 y' = maximum allowable range of thermal stress computed on an elastic basis divided by the yield strength S_y

NOTE: For both y' and x , it is permissible to use $1.5S_m$ whenever it is greater than S_y .

(1) Case 1: Linear variation of temperature through the wall:

$$y' = 1/x \text{ for } 0 < x < 0.5$$

$$y' = 4(1 - x) \text{ for } 0.5 < x < 1.0$$

(2) Case 2: Parabolic constantly increasing or constantly decreasing variation of temperature through the wall:

$$y' = 5.2(1 - x) \text{ for } 0.615 < x < 1.0$$

and approximately for $x < 0.615$ as follows: $y' = 4.65, 3.55,$ and 2.70 for $x = 0.3, 0.4,$ and $0.5,$ respectively.

(b) Use of yield strength S_y in the above relations instead of the proportional limit allows a small amount of growth during each cycle until strain hardening raises the proportional limit to S_y . If the yield strength of the material is higher than two times the S_a value for the maximum number of cycles on the applicable fatigue curve of Section III Appendices, Mandatory Appendix I for the material, the latter value shall be used if there is to be a large number of cycles because strain softening may occur.

NE-3221.7 Deformation Limits. Any deformation limits prescribed by the Design Specifications shall be satisfied.

NE-3222 Buckling Stress Values

NE-3222.1 Basic Compressive Allowable Stress. The maximum buckling stress values to be used for the evaluation of instability shall be either of the following:

(a) one-third the value of critical buckling stress determined by one of the methods given below:

(1) rigorous analysis which considers the effects of gross and local buckling, geometric imperfections, nonlinearities, large deformations, and inertial forces (dynamic loads only);

(2) classical (linear) analysis reduced by margins which reflect the difference between theoretical and actual load capacities;

(3) tests of physical models under conditions of restraint and loading the same as those to which the configuration is expected to be subjected;

(b) the value determined by the applicable rules of NE-3133.

NE-3222.2 Stability Stress Limits.

(a) For Design Conditions and Level A and B Service Limits, the value given in NE-3222.1 shall not be exceeded.

(b) For Level C Service Limits, 120% of the value given in NE-3222.1 shall not be exceeded.

(c) For Level D Service Limits, 150% of the value given in NE-3222.1 shall not be exceeded.

NE-3226 Testing Limits

The evaluation of pressure test loadings (NCA-2142.3) shall be in accordance with (a) through (f) below.

(a) If the calculated pressure, including static head, is to be exceeded at any point in a containment vessel or appurtenance by more than 6%, the resulting stresses shall be calculated by the engineer responsible for the Design Report using an analysis that includes all loadings that may exist during the test. The calculated primary general membrane stress intensity P_m shall not exceed 90% of the tabulated yield strength S_y at the test temperature. For solid rectangular sections, the primary membrane plus primary bending stress intensity $P_m + P_b$ shall not exceed the applicable limits given in (1) or (2) below:

(1) For $P_m \leq 0.67S_y$

$$P_m + P_b \leq 1.35S_y$$

(2) For $0.67S_y < P_m \leq 0.90S_y$

$$P_m + P_b \leq (2.15S_y - 1.2P_m)$$

where S_y is the tabulated yield strength at test temperature.

For other than solid rectangular sections, $P_m + P_b$ shall not exceed a value of α times $0.9S_y$ where the factor α is defined as the ratio of the load set producing a fully plastic section divided by the load set producing initial yielding in the extreme fibers of the section.

(b) If the pneumatic test pressure at any point in a vessel exceeds the required test pressure defined in NE-6321 by more than 6%, the resulting stresses shall be calculated using all of the loadings that may exist during the test. The calculated general primary membrane stress intensity P_m for this situation shall not exceed 80% of the tabulated yield strength S_y at test temperature. For solid rectangular sections, the primary membrane plus primary bending stress intensity $P_m + P_b$ shall not exceed the limits given in (a) above. For other than solid rectangular sections, $P_m + P_b$ shall not exceed a value of α times $0.8S_y$ where the factor α is defined as the ratio of the load set producing a fully plastic section divided by the load set producing initial yielding in the extreme fibers of the section.

(c) In the evaluation of the initial yield and fully plastic section capacities in (a) and (b) above, the ratio of each individual load in the respective load set to each other load

in that load set shall be the same as the respective ratios of the individual loads in the specified design load set. The value of α shall not exceed the value calculated for bending only ($P_m = 0$). In no case shall the value of α exceed 1.5. The propensity for buckling of the part of the section that is in compression shall be investigated.

(d) In multichamber vessels, pressure may be simultaneously applied to the appropriate adjacent chamber to meet the stress limits in (a) and (b) above.

(e) External pressure shall not exceed 125% of the value determined by the rules of NE-3222.

(f) The number of hydrostatic tests in accordance with NE-6220, pneumatic tests in accordance with NE-6320, or any combination of such tests, shall not exceed ten unless a fatigue evaluation is made when required by NE-3221.5. In this fatigue evaluation, the limits on primary plus secondary stress intensity range (NE-3221.4) may be taken as the larger of $3S_m$ or $2S_y$ when at least one extreme of the stress intensity range is determined by the test loadings.

NE-3227 Special Stress Limits

The following stress limits are provided to cover special conditions or configurations. Some of these limits are more restrictive and some less restrictive than the stress intensity limits of NE-3221. In cases of conflict between these requirements and those of NE-3221, the rules of NE-3227 take precedence. The rules of NE-3227 shall apply to Design Loadings and Level A and B Service Loadings. These rules shall also apply to Level C and D Service Loadings unless otherwise justified in the Design Report.

NE-3227.1 Bearing Loads.

(a) The average bearing stress for resistance to crushing under the maximum load, experienced as a result of Design Loadings or of any of the service or testing loadings, shall be limited to S_y at temperature, except that when the distance to a free edge is larger than the distance over which the bearing load is applied, a stress of $1.5S_y$ at temperature is permitted. For clad surfaces, the yield strength of the base metal may be used if, when calculating the bearing stress, the bearing area is taken as the lesser of the actual contact area or the area of the base metal supporting the contact surface.

(b) When bearing loads are applied near free edges, such as at a protruding ledge, the possibility of a shear failure shall be considered. In the case of load-controlled stress only (NE-3213.12), the average shear stress shall be limited to $0.6S_{mc}$. In the case of load-controlled stress plus secondary stress (NE-3213.9), the average shear stress shall not exceed (1) or (2) below:

(1) for materials to which Section II, Part D, Subpart 1, Tables 1A and 1B, Note G5 applies, the lower of $0.5S_y$ at 100°F (38°C) and $0.675S_y$ at temperature;

(2) for all other materials, $0.5S_y$ at temperature.

(c) For clad surfaces, if the configuration or thickness is such that a shear failure could occur entirely within the clad material, the allowable shear stress for the cladding shall be determined from the properties of the equivalent wrought material. If the configuration is such that a shear failure could occur across a path that is partially base metal and partially clad material, the allowable shear stresses for each material shall be used when evaluating the combined resistance to this type of failure.

(d) When considering bearing stresses in pins and similar members, the S_y at temperature value is applicable, except that a value of $1.5S_y$ may be used if no credit is given to bearing area within one pin diameter from a plate edge.

NE-3227.2 Pure Shear.

(a) The average primary shear stress across a section loaded in pure shear experienced as a result of Design Loadings (for example, keys, shear rings, screw threads) shall be limited to $0.6S_{mc}$.

(b) The maximum primary shear experienced as a result of Design Loadings shall be limited to $0.8S_{mc}$.

NE-3227.3 Progressive Distortion of Nonintegral Connections. Screwed-on caps, screwed-in plugs, shear-ring closures, and breech-lock closures are examples of nonintegral connections which are subject to failure by bell mouting or other types of progressive deformation. If any combination of applied loads produces yielding, such joints are subject to ratcheting because the mating members may become loose at the end of each complete service cycle and start the next cycle in a new relationship with each other, with or without manual manipulation. Additional distortion may occur in each cycle so that interlocking parts, such as threads, can eventually lose engagement. Therefore, primary plus secondary stress intensities (NE-3221.4) which result in slippage between the parts of a nonintegral connection in which disengagement could occur as a result of progressive distortion shall be limited to the value S_y (Section II, Part D, Subpart 1, Table Y-1).

NE-3227.4 Triaxial Stresses. The algebraic sum of the three primary principal stresses ($\sigma_1 + \sigma_2 + \sigma_3$) shall not exceed four times the tabulated value of S_{mc} .

NE-3227.5 Nozzle Piping Transition. Within the limits of reinforcement given by NE-3334, whether or not nozzle reinforcement is provided, the P_m classification is applicable to stress intensities resulting from pressure-induced general membrane stresses as well as stresses, other than discontinuity stresses, due to external loads and moments including those attributable to restrained free end displacements of the attached pipe. Also, within the limits of reinforcement, a P_L classification shall be applied to local primary membrane stress intensities derived from discontinuity effects plus primary bending stress intensities due to combined pressure and external

loads and moments including those attributable to restrained free end displacements of the attached pipe; and a $P_L + P_b + Q$ classification shall apply to primary plus secondary stress intensities resulting from a combination of pressure, temperature, and external loads and moments including those due to restrained free end displacements of the attached pipe. Beyond the limits of reinforcement, a P_m classification is applicable to stress intensities resulting from pressure-induced general membrane stresses as well as the average stress across the nozzle thickness due to externally applied nozzle axial, shear, and torsional loads other than those attributable to restrained free end displacement of the attached pipe. Also, outside the limits of reinforcement a $P_L + P_b$ classification is applicable to the stress intensities which result from adding those stresses classified as P_m to those due to externally applied bending moments, except for those attributable to restrained free end displacement of the pipe. Further, beyond the limits of reinforcement, a $P_L + P_b + Q$ classification is applicable to stress intensities resulting from all pressure, temperature, and external loads and moments, including those attributable to restrained free end displacements of the attached pipe. Beyond the limits of reinforcement, the $3S_m$ limit on the range of primary plus secondary stress intensity may be exceeded as provided in NE-3228.3, except that in the evaluation of NE-3228.3(a) stresses from restrained free end displacements of the attached pipe may also be excluded. The range of membrane plus bending stress intensity attributable solely to the restrained free end displacements of the attached piping shall be $\leq 3S_m$. The nozzle, outside the reinforcement limit, shall not be thinner than the larger of the pipe thickness or the quantity $t_p(S_{mp}/S_{mn})$ where t_p is the nominal thickness of the mating pipe, S_{mp} is the allowable stress intensity value for the pipe material, and S_{mn} is the allowable stress intensity value for the nozzle material.

NE-3227.6 Applications of Elastic Analysis for Stresses Beyond the Yield Strength. Certain of the allowable stresses permitted in the criteria are such that the maximum stress calculated on an elastic basis may exceed the yield strength of the material. The limit on primary plus secondary stress intensity of $3S_m$ (NE-3221.4) has been placed at a level which assures shakedown to elastic action after a few repetitions of the stress cycle, except in regions containing significant local structural discontinuities or local thermal stresses. These last two factors are considered only in the performance of a fatigue evaluation. Therefore, the procedures of (a) and (b) below shall be used.

(a) In evaluating stresses for comparison with the stress limits on other than fatigue allowables, stresses shall be calculated on an elastic basis.

(b) In evaluating stresses for comparison with fatigue allowables, all stresses except those which result from local thermal stresses [NE-3213.13(b)] shall be evaluated

on an elastic basis. In evaluating local thermal stresses, the elastic equations shall be used, except that the numerical value substituted for Poisson's ratio shall be determined from the expression:

$$\nu = 0.5 - 0.2 \frac{S_y}{S_{alt}} \text{ but not less than } 0.3$$

where

S_{alt} = alternating stress intensity determined in NE-3221.5(e) prior to the elastic modulus adjustment in NE-3221.5(e)(4)

S_y = the yield strength of the material at the mean value of the temperature of the cycle

NE-3228 Applications of Plastic Analysis

The following subparagraphs provide guidance in the application of plastic analysis and some relaxation of the stress limits of NE-3221 which are allowed if plastic analysis is used.

NE-3228.1 Plastic Analysis. The limits on local membrane stress intensity (NE-3221.2), primary plus secondary stress intensity (NE-3221.4), thermal stress ratchet in shell (NE-3221.6), and progressive distortion of nonintegral connections (NE-3227.3) need not be satisfied at a specific location if, at the location, the procedures of (a) and (b) below are used. (21)

(a) In lieu of satisfying the specific requirements of NE-3221.2, NE-3221.4, NE-3221.6, and NE-3227.3 at a specific location, the structural action is calculated on a plastic basis and the design shall be considered to be acceptable if shakedown occurs (as opposed to continuing deformation) and if the deformations which occur prior to shakedown do not exceed specified limits.

(b) In evaluating stresses for comparison with fatigue allowables, the numerically maximum principal total strain range which occurs after shakedown shall be multiplied by one-half of the modulus of elasticity of the material (Section II, Part D, Subpart 2, Table TM) at the mean value of the temperature of the cycle.

NE-3228.2 Limit Analysis. The limits on local membrane stress intensity (NE-3221.2) and primary membrane plus primary bending stress intensity (NE-3221.3) need not be satisfied at a specific location if it can be shown by means of limit analysis or by tests that the specified loadings do not exceed two-thirds of the lower bound collapse load except for those materials of Section II, Part D, Subpart 1, Table 2A to which Note G7 is applicable and Section II, Part D, Subpart 1, Table 2B to which Note G1 is applicable. For these latter materials the specified loading shall not exceed the product of the applicable permanent strain limiting factor of Section II, Part D, Subpart 1, Table Y-2 times the lower bound collapse load.

Table NE-3228.3(b)-1
Values of m , n , and T_{\max} for Various Classes of Permitted Materials

Materials	m	n	T_{\max} , °F (°C)
Low alloy steel	2.0	0.2	700 (370)
Martensitic stainless steel	2.0	0.2	700 (370)
Carbon steel	3.0	0.2	700 (370)
Austenitic stainless steel	1.7	0.3	800 (425)
Nickel-chromium-iron	1.7	0.3	800 (425)
Nickel-copper	1.7	0.3	800 (425)

NE-3228.3 Simplified Elastic-Plastic Analysis. The $3S_m$ limit on the range of primary plus secondary stress intensity (NE-3221.4) may be exceeded provided the requirements of (a) through (f) below are met.

(a) The range of primary plus secondary membrane plus bending stress intensity, excluding thermal bending stresses, shall be $\leq 3S_m$.

(b) The value of S_n used for entering the design fatigue curve is multiplied by the factor K_e where:

$$\begin{aligned}
 K_e &= 1.0 \text{ for } S_n \leq 3S_m \\
 &= 1.0 + \frac{(1-n)}{n(m-1)} \left(\frac{S_n}{3S_m} - 1 \right) \text{ for } 3S_m < S_n < 3mS_m \\
 &= 1/n \text{ for } S_n \geq 3mS_m \\
 S_n &= \text{range of primary plus secondary stress intensity}
 \end{aligned}$$

The values of the material parameters m and n are given for the various classes of materials in Table NE-3228.3(b)-1.

(c) The rest of the fatigue evaluation stays the same as required in NE-3221.5, except that the procedure of NE-3227.6 need not be used.

(d) The component meets the thermal ratcheting requirement of NE-3221.6.

(e) The temperature does not exceed those listed in Table NE-3228.3(b)-1 for the various classes of materials.

(f) The material shall have a specified minimum yield strength to specified minimum tensile strength ratio of less than 0.80.

NE-3228.4 Impulse Loads. A plastic analysis or test may be used to justify relaxation of the Level A, B, C, and D Service Limits given in NE-3221.1, NE-3221.2, NE-3221.3, and NE-3221.4 if the applied loading is impulsive in nature. The plastic analysis or test shall demonstrate that the factor against failure under the applied impulsive loading is not less than the factor against failure provided by Level A Service Limits for sustained loads. This demonstration shall be included in the Design Report for review by the Owner or the Owner's designee for acceptability to the regulatory authority having jurisdiction at the nuclear power plant site.

NE-3230 STRESS LIMITS FOR BOLTS

NE-3231 Design Conditions

(a) The number and cross-sectional area of bolts required to resist the Design Pressure shall be determined in accordance with the procedures of Section III Appendices, Mandatory Appendix XI, using the larger of the bolt loads given by the equations of Section III Appendices, Mandatory Appendix XI as a Design Mechanical Load. The allowable bolt design stresses shall be as defined in NE-3112.4(b).

(b) When sealing is effected by a seal weld instead of a gasket, the gasket factor m and the minimum design seating stress y may be taken as zero.

(c) When gaskets are used for preservice testing only, the design is satisfactory if the above requirements are satisfied for $m = y = 0$.

NE-3232 Combined Loads

Actual service stresses in bolts, such as those produced by the combination of preload, pressure, and differential thermal expansion, may be higher than the allowable stresses given in NE-3231(a).

NE-3232.1 Average Stress. The maximum value of service stress, averaged across the bolt cross section and neglecting stress concentrations, shall not exceed 2 times the allowable stress values, S , defined in NE-3112.4(b).

NE-3232.2 Maximum Stress. The maximum value of service stress, except as restricted by NE-3232.3, at the periphery of the bolt cross section resulting from direct tension plus bending and neglecting stress concentrations shall not exceed 3 times the allowable stress values, S , defined in NE-3112.4(b). Stress intensity, rather than maximum stress, shall be limited to this value when the bolts are tightened by methods other than heaters, stretchers, or other means which minimize residual torsion.

NE-3232.3 Fatigue Analysis of Bolts. Unless the components on which they are installed meet all the conditions of NE-3221.5(d) and thus require no fatigue analysis, the suitability of bolts for cyclic service shall be determined in accordance with the procedures of (a) through (e) below.

(a) *Bolting Having Less Than 100.0 ksi (700 MPa) Tensile Strength.* Bolts made of materials which have specified minimum tensile strengths of less than 100.0 ksi (700 MPa) shall be evaluated for cyclic service by the methods of NE-3221.5(e) using the applicable design fatigue curve of Section III Appendices, Mandatory Appendix I, Figure I-9.4 and an appropriate fatigue strength reduction factor [(c)].

(b) *High Strength Alloy Steel Bolting.* High strength alloy steel bolts and studs may be evaluated for cyclic service by the methods of NE-3221.5(e) using the design fatigue curve of Section III Appendices, Mandatory Appendix I, Figure I-9.4, provided the requirements of (1), (2), and (3) below are met.

(1) The maximum value of the service stress (NE-3232.2) at the periphery of the bolt cross section (resulting from direct tension plus bending) and neglecting stress concentration shall not exceed $2.7S_m$, if the higher of the two fatigue design curves given in Section III Appendices, Mandatory Appendix I, Figure I-9.4 is used. The limit for direct tension in NE-3232.1 is unchanged.

(2) Threads shall be of a V-type having a minimum thread root radius no smaller than 0.003 in. (0.08 mm).

(3) Fillet radii at the end of the shank shall be such that the ratio of fillet radius to shank diameter is not less than 0.060.

(c) *Fatigue Strength Reduction Factor (NE-3213.17).* Unless it can be shown by analysis or tests that a lower value is appropriate, the fatigue strength reduction factor used in the fatigue evaluation of threaded members shall not be less than 4.0 for the threaded region. However, when applying the rules of (b) for high strength alloy steel bolts, the value used shall not be less than 4 for the threaded region.

(d) *Effect of Elastic Modulus.* Multiply S_{alt} (as determined in NE-3216.1 or NE-3216.2) by the ratio of the modulus of elasticity given on the design fatigue curve to the value of the modulus of elasticity used in the analysis. Enter the applicable design fatigue curve at this value on the ordinate axis and find the corresponding numbers of cycles on the abscissa. If the service cycle being considered is the only one which produces significant fluctuating stresses, this is the allowable number of cycles.

(e) *Cumulative Damage.* The bolts shall be acceptable for the specified cyclic application of loads and thermal stresses provided the cumulative usage factor U as determined in NE-3221.5(e)(5) does not exceed 1.0.

NE-3236 Design Stress Values

Allowable stress values, S , and design stress intensity values, S_m , are defined in NE-3112.4. Values for intermediate temperatures may be found by interpolation. The basis for establishing stress values is given in Section III Appendices, Mandatory Appendix III.

NE-3300 DESIGN BY FORMULA

NE-3310 DESIGN CRITERIA

NE-3311 Requirements for Acceptability

Rules are provided in this subarticle for Design Loadings and Level A and B Service Loadings which do not include substantial mechanical or thermal loads other

than pressure [NE-3131(a)]. The design shall be such that the rules of this subarticle are satisfied for any configurations and loadings explicitly treated.

(a) The allowable stress value at temperature S is defined in NE-3112.4(b).

NE-3320 DESIGN CONSIDERATIONS

NE-3324 Vessels Under Internal Pressure

NE-3324.1 General Requirements. Equations are given in this paragraph for determining the minimum thicknesses under internal pressure loading in cylindrical and spherical shells and ellipsoidal, conical, and hemispherical heads.

NE-3324.2 Nomenclature. The symbols used in Figure NE-3324.2-1 are defined as follows:

D = inside diameter of the head skirt; or inside length of the major axis of an ellipsoidal head; or inside diameter of a conical head at the point under consideration, measured perpendicular to the longitudinal axis

$D/2h$ = ratio of the major to the minor axis of ellipsoidal heads, which equals the inside diameter of the skirt of the head divided by twice the inside height of the head and is used in Table NE-3324.2-1

D_1 = inside diameter of the conical portion of a toriconical head at its point of tangency to the knuckle, measured perpendicular to the axis of the cone

D_o = outside diameter of the head skirt; or outside length of the major axis of an ellipsoidal head; or outside diameter of a conical head at the point under consideration, measured perpendicular to the longitudinal axis

h = one-half of the length of the minor axis of the ellipsoidal head or the inside depth of the ellipsoidal head measured from the tangent line head bend line

K = a factor in the equations for ellipsoidal heads depending on the head proportion $D/2h$ (Table NE-3324.2-1)

L = inside spherical or crown radius for torispherical and hemispherical heads
= $K_1 D$ for ellipsoidal heads in which K_1 is obtained from Table NE-3332.2-1

L_o = outside spherical or crown radius

P = Design Pressure, psi (MPa)

R = inside radius of the shell course under consideration before corrosion allowance is added

r = inside knuckle radius

R_o = outside radius of the shell course under consideration

S = maximum allowable stress value, psi (MPa), as defined in NE-3112.4(b)

Figure NE-3324.2-1
Principal Dimensions of Typical Heads

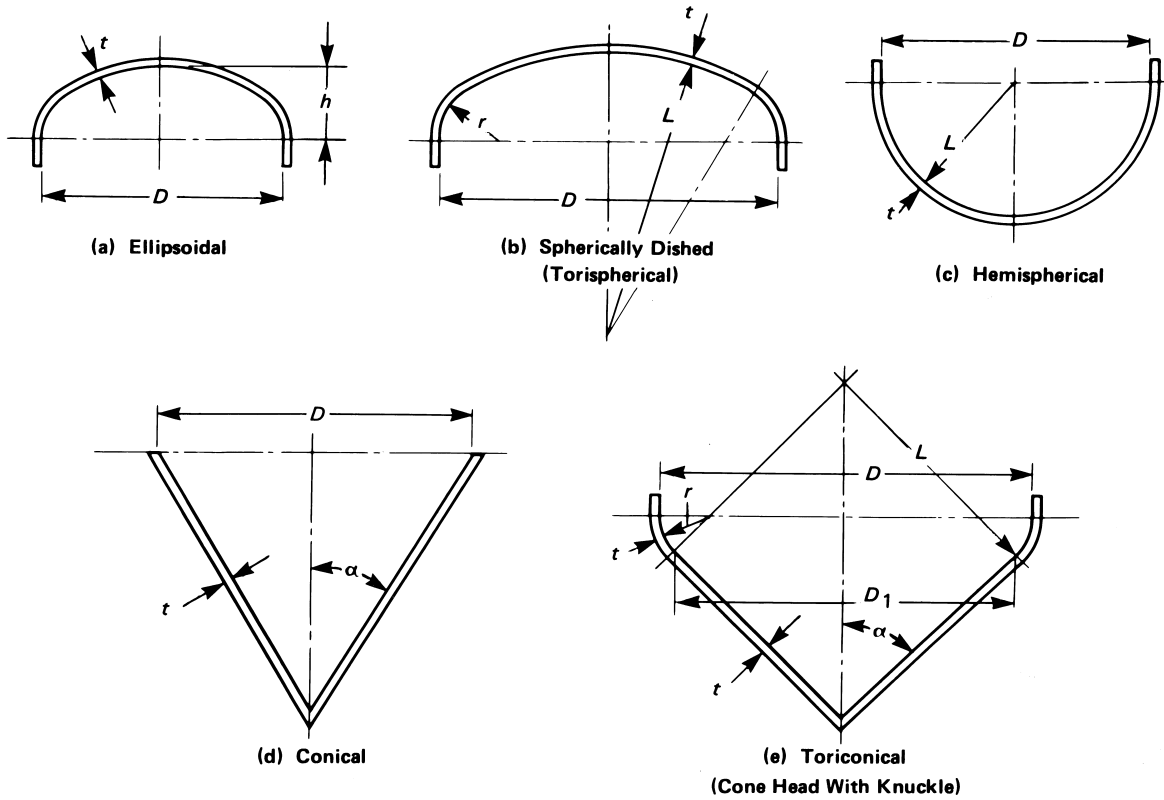

Table NE-3324.2-1
Values of Factor K

$D/2h$	3.0	2.9	2.8	2.7	2.6	2.5	2.4	2.3	2.2	2.1	2.0
K	1.83	1.73	1.64	1.55	1.46	1.37	1.29	1.21	1.14	1.07	1.00
$D/2h$	1.9	1.8	1.7	1.6	1.5	1.4	1.3	1.2	1.1	1.0	
K	0.93	0.87	0.81	0.76	0.71	0.66	0.61	0.57	0.53	0.50	...

GENERAL NOTE: Use nearest value of $D/2h$; interpolation unnecessary.

t = minimum required thickness of shell or head, after forming, exclusive of corrosion allowance
 α = one-half of the included apex angle of the cone at the center line of the head

NE-3324.3 Cylindrical Shells. The minimum thickness of cylindrical shells shall be the greater thickness as given by (a) through (d) below.

(a) *Circumferential Stress (Longitudinal Joints).* When the thickness does not exceed one-half of the inside radius, or P does not exceed $0.385S$, the following equations shall apply:

$$t = \frac{PR}{S - 0.6P} \quad \text{or} \quad P = \frac{St}{R + 0.6t}$$

(b) *Longitudinal Stress (Circumferential Joints).* When the thickness does not exceed one-half of the inside radius, or P does not exceed $1.25S$, the following equations shall apply:

$$t = \frac{PR}{2S + 0.4P} \quad \text{or} \quad P = \frac{2St}{R - 0.4t}$$

(c) *Thickness of Cylindrical Shells.* The following equations, in terms of the outside radius, are equivalent to and may be used instead of those given in (a) above:

$$t = \frac{(PR_o)}{S + 0.4P} \quad \text{or} \quad P = \frac{St}{(R_o - 0.4t)}$$

(d) *Thick Cylindrical Shells*

(1) Circumferential Stress (Longitudinal Joints).

When the thickness of the cylindrical shell under internal pressure exceeds one-half of the inside radius, or when P exceeds $0.385S$, the following equations shall apply.

When P is known and t is desired:

$$t = R(Z^{1/2} - 1) = R_o \frac{(Z^{1/2} - 1)}{Z^{1/2}}$$

where

$$Z = \frac{S + P}{S - P}$$

When t is known and P is desired:

$$P = S \left(\frac{Z - 1}{Z + 1} \right)$$

where

$$Z = \left(\frac{R + t}{R} \right)^2 = \left(\frac{R_o}{R} \right)^2 = \left(\frac{R_o}{R_o - t} \right)^2$$

(2) Longitudinal Stress (Circumferential Joints).

When the thickness of the cylindrical shell under internal pressure exceeds one-half of the inside radius, or when P exceeds $1.25S$, the following equations shall apply.

When P is known and t is desired:

$$t = R(Z^{1/2} - 1) = R_o \frac{(Z^{1/2} - 1)}{Z^{1/2}}$$

where

$$Z = \left(\frac{P}{S} + 1 \right)$$

When t is known and P is desired:

$$P = S(Z - 1)$$

where

$$Z = \left(\frac{R + t}{R} \right)^2 = \left(\frac{R_o}{R} \right)^2 = \left(\frac{R_o}{R_o - t} \right)^2$$

NE-3324.4 Spherical Shells.

(a) When the thickness of the shell of a spherical vessel does not exceed $0.356R$, or P does not exceed $0.665S$, the following equations shall apply. Any reduction in thickness within a shell course of a spherical shell shall be in accordance with [NE-3361](#).

$$t = \frac{PR}{2S - 0.2P} \quad \text{or} \quad P = \frac{2St}{R + 0.2t}$$

(b) The following equations, in terms of the outside radius, are equivalent to and may be used instead of those given in (a) above:

$$t = \frac{PR_o}{2S + 0.8P} \quad \text{or} \quad P = \frac{2St}{R_o - 0.8t}$$

(c) When the thickness of the shell of a spherical vessel or of a hemispherical head under internal pressure exceeds $0.356R$, or when P exceeds $0.665S$, the following equations shall apply.

When P is known and t is desired:

$$t = R(Y^{1/3} - 1) = R_o \left(\frac{Y^{1/3} - 1}{Y^{1/3}} \right)$$

where

$$Y = \frac{2(S + P)}{2S - P}$$

When t is known and P is desired:

$$P = 2S \left(\frac{Y - 1}{Y + 2} \right)$$

where

$$Y = \left(\frac{R + t}{R} \right)^3 = \left(\frac{R_o}{R_o - t} \right)^3$$

NE-3324.5 Formed Heads, General Requirements.

Formed heads shall meet the requirements of (a) through (f) below.

(a) All formed heads, thicker than the shell and concave to pressure, for butt-welded attachment, shall have a skirt length sufficient to meet the requirements of [Figure NE-3358.1\(a\)-1](#) when a tapered transition is required.

(b) Any taper at a welded joint within a formed head shall be in accordance with [NE-3361](#). The taper at a circumferential welded joint connecting a formed head to a main shell shall meet the requirements of [NE-3358](#) for the respective type of joint shown therein.

(c) All formed heads concave to pressure and for butt-welded attachment need not have an integral skirt when the thickness of the head is equal to or less than the thickness of the shell. When a skirt is provided, its thickness shall be at least that required for a seamless shell of the same diameter.

(d) The inside crown radius to which a head is dished shall not be greater than the outside diameter of the skirt of the head. The inside knuckle radius of a torispherical head shall not be less than 6% of the outside diameter of the skirt of the head but in no case less than three times the head thickness.

(e) If a torispherical, ellipsoidal, or hemispherical head is formed with a flattened spot or surface, the diameter of the flat spot shall not exceed that permitted for flat heads as given by eq. NE-3325.2(b)(1) or eq. NE-3325.2(b)(2) using $C = 0.25$.

(f) Openings in formed heads under internal pressure shall comply with the requirements of NE-3330.

NE-3324.6 Ellipsoidal Heads.

(a) *Ellipsoidal Heads.* The required thickness of a dished head of semiellipsoidal form, in which one-half the minor axis, inside depth of the head minus the skirt, equals one-fourth the inside diameter of the head skirt, shall be determined by:

$$t = \frac{PD}{2S - 0.2P} \quad \text{or} \quad P = \frac{2St}{D + 0.2t}$$

(b) *Ellipsoidal Heads of Other Ratios.* The minimum required thickness of an ellipsoidal head of other than a 2:1 ratio shall be determined by:

$$t = \frac{PDK}{2S - 0.2P} \quad \text{or} \quad P = \frac{2St}{KD + 0.2t}$$

$$t = \frac{PD_oK}{2S + 2P(K - 0.1)}$$

or

$$P = \frac{2St}{KD_o - 2t(K - 0.1)}$$

where

$$K = \frac{1}{6} \left[2 + \left(\frac{D}{2h} \right)^2 \right]$$

Numerical values of the factor K are given in [Table NE-3324.2-1](#)

NE-3324.7 Hemispherical Heads.

(a) When the thickness of a hemispherical head does not exceed $0.356L$ or P does not exceed $0.665S$, the following equations shall apply:

$$t = \frac{PL}{2S - 0.2P} \quad \text{or} \quad P = \frac{2St}{L + 0.2t}$$

(b) When the thickness of the hemispherical head under internal pressure exceeds $0.356L$, or when P exceeds $0.665S$, the following equations shall apply:

$$t = L \left(Y^{1/3} - 1 \right) = L_o \left(\frac{Y^{1/3} - 1}{Y^{1/3}} \right)$$

where

$$Y = \frac{2(S + P)}{2S - P}$$

or

$$P = 2S \left(\frac{Y - 1}{Y + 2} \right)$$

where

$$Y = \left(\frac{L + t}{L} \right)^3 = \left(\frac{L_o}{L_o - t} \right)^3$$

NE-3324.8 Torispherical Heads.

(a) *Torispherical Heads With a 6% Knuckle Radius.* The required thickness of a torispherical head in which the knuckle radius is 6% of the inside crown radius shall be determined by:

$$t = \frac{0.885PL}{S - 0.1P} \quad \text{or} \quad P = \frac{St}{0.885L + 0.1t}$$

(b) *Torispherical Heads of Other Proportions.* The required thickness of a torispherical head in which the knuckle radius is other than 6% of the crown radius shall be determined by:

$$t = \frac{PLM}{2S - 0.2P} \quad \text{or} \quad P = \frac{2St}{LM + 0.2t}$$

$$t = \frac{PL_oM}{2S + P(M - 0.2)}$$

or

$$P = \frac{2St}{ML_o - t(M - 0.2)}$$

where

$$M = \frac{1}{4} \left(3 + \sqrt{\frac{L}{r}} \right)$$

Numerical values of the factor M are given in [Table NE-3324.8\(b\)-1](#).

**Table NE-3324.8(b)-1
Values of Factor M**

<i>L/r</i>	1.0	1.25	1.50	1.75	2.00	2.25	2.50	2.75	3.00	3.25	3.50
<i>M</i>	1.00	1.03	1.06	1.08	1.10	1.13	1.15	1.17	1.18	1.20	1.22
<i>L/r</i>	4.0	4.5	5.0	5.5	6.0	6.5	7.0	7.5	8.0	8.5	9.0
<i>M</i>	1.25	1.28	1.31	1.34	1.36	1.39	1.41	1.44	1.46	1.48	1.50
<i>L/r</i>	9.5	10.00	10.5	11.0	11.5	12.0	13.0	14.0	15.0	16.0	16.67 [Note (1)]
<i>M</i>	1.52	1.54	1.56	1.58	1.60	1.62	1.65	1.69	1.72	1.75	1.77

GENERAL NOTE: Use nearest value of *L/r*; interpolation unnecessary.

NOTE: (1) Maximum ratio allowed by NE-3324.5(d) when *L* equals the outside diameter of the skirt of the head.

(c) Torispherical heads made of materials having a specified minimum tensile strength exceeding 80 ksi (550 MPa) shall be designed using a value of *S* equal to 22 ksi (150 MPa) at room temperature and reduced in proportion to the ratio of the reduction in maximum allowable stress values from room temperature to design temperature for the material as shown in Section II, Part D, Subpart 1, Tables 1A and 1B.

NE-3324.9 Conical Heads Without Transition Knuckle.

The required thickness of conical heads or conical shell sections that have a half apex angle α not greater than 30 deg shall be determined by:

$$t = \frac{PD}{2 \cos \alpha (S - 0.6P)} \quad \text{or} \quad P = \frac{2St \cos \alpha}{D + 1.2t \cos \alpha}$$

For α greater than 30 deg, see NE-3324.11(b)(5). A compression ring shall be provided when required by the rule in NE-3324.11(b).

NE-3324.10 Toriconical Heads. Toriconical heads in which the inside knuckle radius is neither less than 6% of the outside diameter of the head skirt nor less than three times the knuckle thickness shall be used when the angle α exceeds 30 deg except when the design complies with NE-3324.11. The required thickness of the knuckle shall be determined by the first equation of NE-3324.8(b) in which:

$$L = \frac{D_1}{2 \cos \alpha}$$

The required thickness of the conical portion shall be determined by the equation in NE-3324.9, using D_1 in place of *D*.

NE-3324.11 Reducer Sections.

(a) General Requirements

(1) The rules of (a) apply to concentric reducer sections.

(2) The symbols used are defined as follows:

A = required area of reinforcement, in.² (mm²)

A_e = effective area of reinforcement, due to excess metal thickness, in.² (mm²)

D₁ = inside diameter of reducer section at point of tangency to the knuckle or reverse curve, in. (mm)

m = the lesser of

$$\left[\frac{t_s}{t} \cos(\alpha - \Delta) \right]$$

or

$$\left[\frac{t_c \cos \alpha \cos(\alpha - \Delta)}{t} \right]$$

R_L = inside radius of larger cylinder, in. (mm)

r_L = inside radius of knuckle at larger cylinder, in. (mm)

R_s = inside radius of smaller cylinder, in. (mm)

r_s = radius to the inside surface of flare at the small end, in. (mm)

t_c = nominal thickness of cone at cone-to-cylinder junction, exclusive of corrosion allowance, in. (mm)

t_e = the smaller of (*t_s* - *t*) or [*t_c* - (*t*/cos α)], in. (mm)

t_s = nominal thickness of cylinder at cone-to-cylinder junction, exclusive of corrosion allowance, in. (mm)

Δ = value to indicate need for reinforcement at cone-to-cylinder intersection having a half-apex angle $\alpha \leq 30$ deg. When $\Delta \geq \alpha$, no reinforcement at the junction is required [Tables NE-3324.11(b)(2)-1 and NE-3324.11(b)(3)-1].

(3) The thickness of each element of a reducer, as defined in (4) below, under internal pressure shall not be less than that computed by the applicable equation.

(4) A transition section reducer consisting of one or more elements may be used to join two cylindrical shell sections of different diameters but with a common axis, provided the requirements of (-a) and (-b) below are met.

Table NE-3324.11(b)(2)-1
Values of Δ for Junctions at the Large Cylinder for $\alpha \leq 30$ deg

<i>P/S</i>	0.001	0.002	0.003	0.004	0.005	0.006	0.007	0.008	0.009 [Note (1)]
Δ , deg	11	15	18	21	23	25	27	28.5	30

NOTE: (1) $\Delta = 30$ deg for greater values of *P/S*.

(-a) *Conical Shell Section*. The required thickness of a conical shell section or the allowable pressure for such a section of given thickness shall be determined by the equations given in NE-3324.9.

(-b) *Knuckle Tangent to the Larger Cylinder*. Where a knuckle is used at the large end of a reducer section, its shape shall be that of a portion of an ellipsoidal, hemispherical, or torispherical head. The thickness and other dimensions shall satisfy the requirements.

(5) When elements of (4) above having different thicknesses are combined to form a reducer, the joints, including the plate taper required by NE-3361, shall lie entirely within the limits of the thinner element being joined.

(6) A reducer may be a simple conical shell section [Figure NE-3324.11(a)(6)-1, sketch (a)] without knuckle, provided the half apex angle α is not greater than 30 deg, except as provided for in (b) below. A reinforcement ring shall be provided at either or both ends of the reducer when required by (b) below.

(7) A toriconical reducer [Figure NE-3324.11(a)(6)-1, sketch (b)] may be shaped as a portion of a toriconical shell, a portion of a hemispherical head plus a conical section, or a portion of an ellipsoidal head plus a conical section, provided the half apex angle α is not greater than 30 deg, except as provided for in (b) below. A reinforcement ring shall be provided at the small end of a conical reducer element when required by (b) below.

(8) Reverse curve reducers [Figure NE-3324.11(a)(6)-1, sketches (c) and (d)] may be shaped of elements other than those illustrated.

(b) *Supplementary Requirements for Reducer Sections and Conical Heads Under Internal Pressure*

Table NE-3324.11(b)(3)-1
Values of Δ for Junctions at the Small Cylinder
for $\alpha \leq 30$ deg

<i>P/S</i>	0.002	0.005	0.010	0.02	0.04	0.08	0.10	0.125 [Note (1)]
Δ , deg	4	6	9	12.5	17.5	24	27	30

NOTE: (1) $\Delta = 30$ deg for greater values of *P/S*.

(1) The equations of (2) and (3) below provide for the design of reinforcement, if needed, at the cone-to-cylinder junctions for reducer sections and conical heads where all the elements have a common axis and the half apex angle $\alpha \leq 30$ deg. In (5) below, provision is made for special analysis in the design of cone-to-cylinder intersections with or without reinforcing rings where α is greater than 30 deg.

(2) Reinforcement shall be provided at the junction of the cone with the large cylinder for conical heads and reducers without knuckles when the value of Δ obtained from Table NE-3324.11(b)(2)-1, using the appropriate ratio *P/S*, is less than α . Interpolation may be made in the table.

(-a) The cross-sectional area of the reinforcement ring shall be at least equal to that indicated by the following equation:

$$A = \frac{PR_L^2}{2S} \left(1 - \frac{\Delta}{\alpha} \right) \tan \alpha$$

(-b) When the thickness, less corrosion allowance, of both the reducer and cylinder exceeds that required by the applicable design equations, the minimum excess thickness may be considered to contribute to the required reinforcement ring in accordance with the following equation:

$$A_e = 4t_e \sqrt{R_L t_s}$$

(-c) Any additional area of reinforcement which is required shall be situated within a distance of $\sqrt{R_L t_s}$ from the junction of the reducer and the cylinder. The centroid of the added area shall be within a distance of $\sqrt{0.5R_L t_s}$ from the junction.

(3) Reinforcement shall be provided at the junction of the conical shell of a reducer without a flare and the small cylinder when the value of Δ obtained from Table NE-3324.11(b)(3)-1, using the appropriate ratio *P/S*, is less than α .

(-a) The cross-sectional area of the reinforcement ring shall be at least equal to that indicated by the following equation:

$$A = \frac{PR_s^2}{2S} \left(1 - \frac{\Delta}{\alpha} \right) \tan \alpha$$

Figure NE-3324.11(a)(6)-1
Large Head Openings: Reverse Curve and Conical Shell Reducer Sections

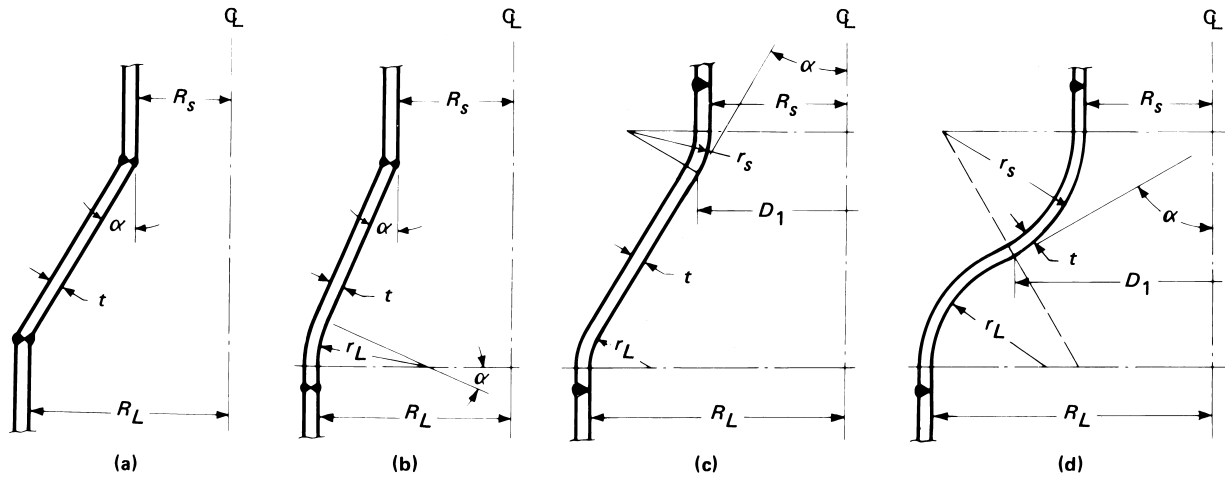

GENERAL NOTES:

- (a) r_L shall not be less than the small of $0.12(R_L + t)$ or $3t$
 (b) r_s has no dimensional requirement

(-b) When the thickness, less corrosion allowance, of either the reducer or cylinder exceeds that required by the applicable design equation, the excess thickness may be considered to contribute to the required reinforcement ring in accordance with the following equation:

$$A_e = m \sqrt{R_s t} [t_c - (t / \cos \alpha) + (t_s - t)]$$

(-c) Any additional area of reinforcement which is required shall be situated within a distance of $\sqrt{R_s t_s}$ from the junction, and the centroid of the added area shall be within a distance of $0.5 \sqrt{R_s t_s}$ from the junction.

(4) Reducers not described in (a)(3), such as those made up of two or more conical frustums having different slopes, may be designed in accordance with (5) below.

(5) When the half apex angle α is greater than 30 deg, cone-to-cylinder junctions without a knuckle may be used, with or without reinforcing rings, if the design is based on stress analysis. When a stress analysis is made, the calculated stresses shall be evaluated in accordance with NE-3200.

NE-3324.12 Nozzles.

(a) The wall thickness of a nozzle or other connection shall not be less than the nominal thickness of the connecting piping. In addition, the wall thickness shall not be less than the thickness computed for the applicable loadings in NE-3111 plus the thickness added for corrosion. Except for access openings and openings for inspection only, the wall thickness shall not be less than the smaller of (1) and (2) below:

(1) the required thickness of the shell or head to which the connection is attached plus the corrosion allowance provided in the shell or head adjacent to the connection;

(2) the nominal wall thickness of standard wall pipe listed in ASME B36.10M less 12.5% plus the corrosion allowance on the connection. For diameters other than those listed in ASME B36.10M, nominal wall shall be based on the next larger pipe size; for nozzles larger than the largest pipe size included in ASME B36.10M, the nominal wall shall be based on largest size listed.

(b) The allowable stress value for shear in a nozzle neck shall be 70% of the allowable tensile stress for the vessel material.

NE-3325 Flat Heads and Covers

The minimum thickness of unstayed flat heads, cover plates, and blind flanges shall conform to the requirements given in this paragraph. These requirements apply to circular heads and covers. Some acceptable types of flat heads and covers are shown in Figure NE-3325-1. In this figure the dimensions of the component parts and the dimensions of the welds are exclusive of extra metal required for corrosion allowance.

NE-3325.1 Nomenclature. The symbols used are defined as follows:

C = a factor depending upon the method of attachment of head, shell dimensions, and other items as listed in NE-3325.3, dimensionless

Figure NE-3325-1
Some Acceptable Types of Unstayed Flat Heads and Covers

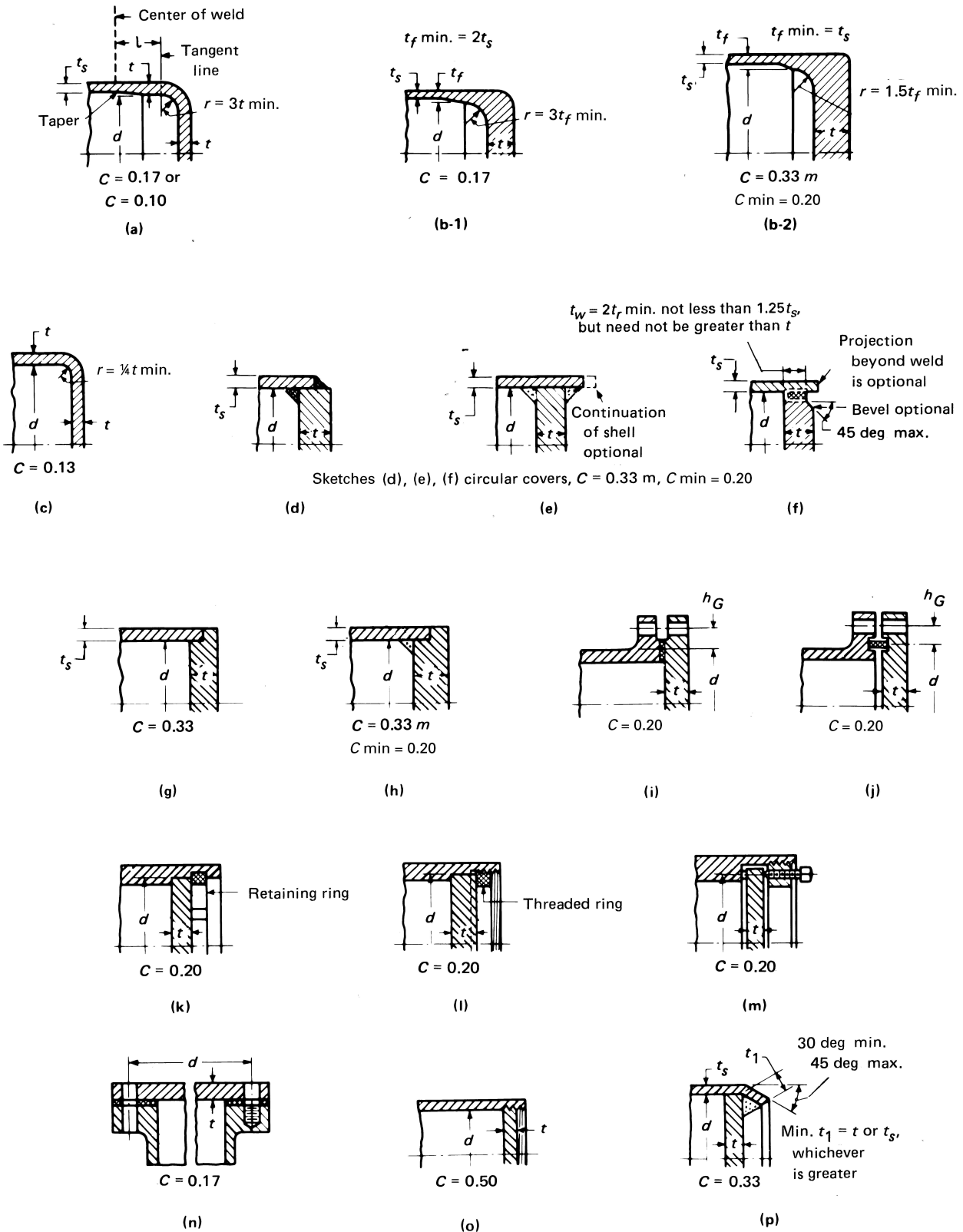

- d = diameter, measured as indicated in [Figure NE-3325-1](#)
- h_G = gasket moment arm, equal to the radial distance from the center line of the bolts to the line of the gasket reaction, as shown in Section III Appendices, Mandatory Appendix XI, Table XI-3221.2-2
- l = length of flange of flanged heads, measured from the tangent line of knuckle, as indicated in [Figure NE-3325-1](#), sketches (a) and (c)
- m = the ratio t_r/t_s
- P = Design Pressure, psi (MPa)
- r = inside corner radius on a head formed by flanging or forging
- S = maximum allowable stress, psi (MPa), as defined in [NE-3112.4\(b\)](#)
- t = minimum required thickness of flat head or cover, exclusive of corrosion allowance
- t_1 = throat dimension of the closure weld, as indicated in [Figure NE-3325-1](#), sketch (p)
- t_f = actual thickness of the flange on a forged head, at the large end, exclusive of corrosion allowance, as indicated in [Figure NE-3325-1](#), sketches (b-1) and (b-2)
- t_h = actual thickness of flat head or cover, exclusive of corrosion allowance
- t_p = the smallest dimension from the face of the head to the edge of the weld preparation
- t_r = required thickness of shell, for pressure
- t_s = actual thickness of shell, exclusive of corrosion allowance
- t_w = thickness through the weld joining the edge of a head to the inside of a vessel, as indicated in [Figure NE-3325-1](#), sketch (f)
- W = total bolt load, lb (kN), given for circular heads for Section III Appendices, Mandatory Appendix XI, Article XI-3000, eqs. XI-3223(3) and XI-3223(4)

NE-3325.2 Thickness. The thickness of flat unstayed heads, covers, and blind flanges shall conform to one of the following two requirements.

NOTE: The equations provide structural integrity as far as stress is concerned. Greater thicknesses may be necessary if deflection would cause leakage at threaded or gasketed joints.

(a) Circular blind flanges of ferrous materials conforming to ASME B16.5 shall be acceptable for the diameters and pressure temperature ratings in Tables 2 to 8 of that Standard, when of the types shown in [Figure NE-3325-1](#), sketches (j) and (k).

(b) The minimum required thickness of flat unstayed circular heads, covers, and blind flanges shall be calculated by the equation:

$$t = d \sqrt{CP/S} \quad (1)$$

except when the head, cover, or blind flange is attached by bolts causing an edge moment [[Figure NE-3325-1](#) sketches (i), (j), and (n)], in which case the thickness shall be calculated by:

$$t = d \sqrt{CP/S + 1.27 Wh_G/Sd^3} \quad (2)$$

When using [eq. \(2\)](#), the thickness t shall be calculated for both Service Loadings and gasket seating, and the greater of the two values shall be used. For Service Loadings, the value of P shall be the Design Pressure, and the values of S at the Design Temperature and W from Section III Appendices, Mandatory Appendix XI, Article XI-3000, eq. XI-3223(3) shall be used. For gasket seating, P equals zero, and the values of S at atmospheric temperature and W from Section III Appendices, Mandatory Appendix XI, Article XI-3000, eq. XI-3223(4) shall be used.

NE-3325.3 Values of C. For the types of construction shown in [Figure NE-3325-1](#) and [Figure NE-4243.1-1](#), the minimum values of C to be used in [eqs. NE-3325.2\(b\)\(1\)](#) and [NE-3325.2\(b\)\(2\)](#) shall be as given in (a) through (l) below for [Figure NE-3325-1](#) and in (m) below for [Figure NE-4243.1-1](#).

(a) In sketch (a), $C = 0.17$ for flanged circular heads forged integral with or butt welded to the vessel with an inside corner radius not less than three times the required head thickness, with no special requirement with regard to length of flange.

(1) $C = 0.10$ for circular heads, when the flange length for heads of the above design is not less than:

$$l = \left[1.1 - 0.8 \frac{t_s^2}{t_h^2} \right] \sqrt{dt_h} \quad (3)$$

(2) $C = 0.10$ for circular heads, when the flange length l is less than the requirement in [eq. \(1\)\(3\)](#) but the shell thickness is not less than:

$$t_s = 1.12t_h \sqrt{1.1 - l/\sqrt{dt_h}} \quad (4)$$

for a length of at least $2\sqrt{dt_s}$.

(3) When $C = 0.10$ is used, the taper shall be 1:4.

(b) In sketch (b-1), $C = 0.17$ for forged circular heads integral with or butt welded to the vessel, where the flange thickness is not less than two times the shell thickness, the corner radius on the inside is not less than three times the flange thickness and the welding meets all the requirements of [Article NE-4000](#).

(c) In sketch (b-2), $C = 0.33m$ but not less than 0.20 for forged circular heads integral with or butt welded to the vessel, where the flange thickness is not less than the shell thickness and the corner radius on the inside is not less than 1.5 times the flange thickness. [See [Figure](#)

NE-4243.1-1, sketches (a) and (b) for the special case where $t_f = t_s$]

(d) In sketch (c), $C = 0.13$ for integral flat circular heads when the dimension d does not exceed 24 in. (600 mm), the ratio of thickness of the head to the dimension d is not less than 0.05 nor greater than 0.25, the head thickness t_h is not less than the shell thickness t_s , the inside corner radius is not less than $0.25t$, and the construction is obtained by special techniques of upsetting and spinning the end of the shell, such as employed in closing header ends.

(e) In sketches (d), (e), and (f), $C = 0.33m$ but not less than 0.20 for circular plates welded to the inside of a vessel and otherwise meeting the requirements for the respective types of welded vessels. If a value of m less than 1 is used in calculating t , the shell thickness t_s shall be maintained along a distance inwardly from the inside face of the head equal to at least $2\sqrt{dt_s}$. The throat thickness of the fillet welds in sketch (e) shall be at least $0.7t_s$. The size of the weld t_w in sketch (f) shall not be less than 2 times the required thickness of a seamless shell nor less than 1.25 times the nominal shell thickness but need not be greater than the head thickness; the weld shall be deposited in a welding groove with the root of the weld at the inner face of the head as shown in the figure.

(f) In sketch (g), $C = 0.33$ for circular plates welded to the end of the shell when t_s is at least $1.25t_r$ and the weld details conform to the requirements of NE-3358.3(e) and Figure NE-4243-1, sketches (a) through (g).

(g) In sketch (h), $C = 0.33m$ but not less than 0.20 for circular plates if an inside fillet weld with minimum throat thickness of $0.7t_s$ is used and the details of the outside weld conform to the requirements of NE-3358.3(c) and Figure NE-4243-1, sketches (a) through (g), in which the inside weld can be considered to contribute an amount equal to t_s to the sum of the dimensions a and b .

(h) In sketches (i) and (j), $C = 0.20$ for circular heads and covers bolted to the vessel as indicated in the figures. Note that eq. NE-3325.2(b)(2) shall be used because of the extra moment applied to the cover by the bolting. When the cover plate is grooved for a peripheral gasket as shown in sketch (j), the net cover plate thickness under the groove or between the groove and the outer edge of the cover plate shall not be less than $d\sqrt{1.27Wh_G / Sd^3}$ for circular heads and covers.

(i) In sketches (k), (l), and (m), $C = 0.20$ for a circular plate inserted into the end of a vessel and held in place by a positive mechanical locking arrangement, and when all possible means of failure (either by shear, tension, compression, or radial deformation, including flaring, resulting from pressure and differential thermal expansion) are resisted using stresses consistent with this Article. Seal welding may be used, if desired.

(j) In sketch (n), $C = 0.17$ for circular covers, bolted with a full-face gasket, to shells, flanges, or side plates.

(k) In sketch (o), $C = 0.50$ for circular plates screwed into the end of a vessel having an inside diameter d not exceeding 12 in. (300 mm), or for heads having an integral flange screwed over the end of a vessel having an inside diameter d not exceeding 12 in. (300 mm), and when the design of the threaded joint against failure by shear, tension, compression, or radial deformation, including flaring resulting from pressure and differential thermal expansion, is based on stresses consistent with this Article. Seal welding may be used.

(l) In sketch (p), $C = 0.33$ for circular plates having a dimension d not exceeding 18 in. (450 mm) inserted into the vessel as shown and otherwise meeting the requirements for the respective types of welded vessels. The end of the vessel shall be crimped over at least 30 deg but not more than 45 deg. The throat of the weld shall not be less than the thickness of the flat head or shell, whichever is greater.

(m) In Figure NE-4243.1-1, $C = 0.33m$ but not less than 0.20 when the dimensional requirements of NE-3358.4 are met.

NE-3326 Spherically Dished Covers With Bolting Flanges

NE-3326.1 Nomenclature. The symbols used are defined as follows:

- A = outside diameter of flange
- B = inside diameter of flange
- C = bolt circle diameter
- H_D = axial component of the membrane load in the spherical segment, lb (N), acting at the inside of the flange ring = $0.785B^2P$
- h_D = radial distance from the bolt circle to the inside of the flange ring
- H_r = radial component of the membrane load in the spherical segment = $H_D \cot \beta_1$, lb (N), acting at the intersection of the inside of the flange ring with the center line of the dished cover thickness
- h_r = lever arm of H_r about centroid of flange ring
- L = inside spherical or crown radius
- M_o = the total moment, in.-lb (kN·m), determined as in Section III Appendices, Mandatory Appendix XI, XI-3230 for heads concave to pressure, and Section III Appendices, Mandatory Appendix XI, XI-3260 for heads convex to pressure; except that for heads of the type shown in Figure NE-3326.1-1 sketch (d), H_D and h_D shall be as defined in this subparagraph, and an additional moment $H_r h_r$ shall be included

NOTE: Since $H_r h_r$ in some cases will subtract from the total moment, the moment in the flange ring when the internal pressure is zero may be the determining loading for the flange design.

P = Design Pressure, psi (MPa)

Figure NE-3326.1-1
Spherically Dished Covers With Bolting Flanges

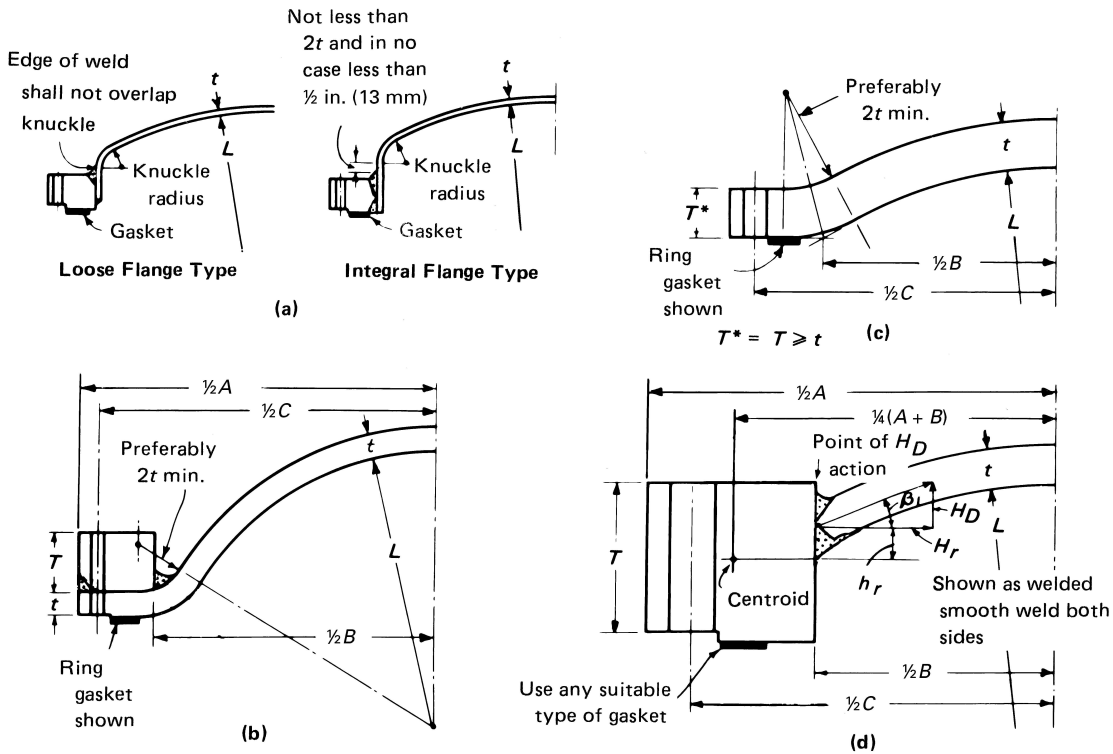

- r = inside knuckle radius
- S = maximum allowable stress value, psi (MPa), as defined in NE-3112.4(b)
- T = flange thickness
- t = minimum required thickness of head plate after forming
- β_1 = angle formed by the tangent to the center line of the dished cover thickness at its point of intersection with the flange ring, and a line perpendicular to the axis of the dished cover, where

$$\beta = \arcsin\left(\frac{B}{2L + t}\right)$$

NE-3326.2 Spherically Dished Heads With Bolting Flanges. Circular spherically dished heads with bolting flanges, both concave and convex to the pressure and conforming to the several types illustrated in Figure NE-3326.1-1, shall be designed in accordance with the requirements of (a) through (d) below. For heads convex to pressure, the spherical segments shall be thickened, if necessary, to meet the requirements of NE-3133. The actual value of the total moment M_o may

calculate to be either plus or minus for both the heads concave to pressure and the heads convex to pressure. However, for use in all of the equations which follow, the absolute values for both P and M_o shall be used.

(a) Heads of the type shown in Figure NE-3326.1-1, sketch (a):

- (1) the thickness of the head t shall be determined by the appropriate equation in NE-3324;
- (2) the head radius L or the knuckle radius r shall not exceed the limitations given in NE-3324;

(3) the flange shall comply with at least the requirements of Section III Appendices, Mandatory Appendix XI, Figure XI-3120-1 and shall be designed in accordance with the applicable provisions of Section III Appendices, Mandatory Appendix XI; within the range of ASME B16.5, the flange facings and drillings should conform to those Standards and the thickness specified therein shall be considered as a minimum requirement.

(b) Heads of the type shown in Figure NE-3326.1-1, sketch (b):

- (1) head thickness t

$$t = \frac{SPL}{6S} \tag{5}$$

(2) flange thickness T
 (-a) for ring gasket

$$T = \sqrt{\frac{M_o}{SB} \left[\frac{A + B}{A - B} \right]} \quad (6)$$

(-b) for full-faced gasket

$$T = 0.6 \sqrt{\frac{P}{S} \left[\frac{B(A + B)(C - B)}{A - B} \right]} \quad (7)$$

NOTE: The radial components of the membrane load in the spherical segment are assumed to be resisted by its flange.

Within the range of ASME B16.5, the flange facings and drillings should conform to those Standards, and the thickness specified therein shall be considered as a minimum requirement.

(c) Heads of the type shown in Figure NE-3326.1-1, sketch (c):

(1) Head thickness:

$$t = \frac{5PL}{6S} \quad (8)$$

(2) Flange thickness for ring gaskets shall be calculated as follows:

(-a) for heads with round bolting holes:

$$T = Q + \sqrt{\frac{1.875 M_o(C + B)}{SB(7C - 5B)}} \quad (9)$$

where Q , in. (mm)

$$Q = \frac{PL}{4S} \left(\frac{C + B}{7C - 5B} \right) \quad (10)$$

(-b) for heads with bolting holes slotted through the edge of the head:

$$T = Q + \sqrt{\frac{1.875 M_o(C + B)}{SB(3C - B)}} \quad (11)$$

where Q , in. (mm)

$$Q = \frac{PL}{4S} \left(\frac{C + B}{3C - B} \right) \quad (12)$$

(3) Flange thickness for full face gaskets shall be as calculated in eq. (13):

$$T = Q + \sqrt{Q^2 + \frac{3BQ(C - B)}{L}} \quad (13)$$

The value of Q in eq. (13) is calculated by eq. (2)(-a)(10) for round bolting holes or by eq. (2)(-b)(12) for bolting holes slotted through the edge of the head [see (2) above].

(4) The required flange thickness shall be T as calculated in eq. (b)(2)(-a)(6) or eq. (b)(2)(-b)(7) above, but in no case less than the value of t as calculated in eq. (b)(1)(5);

(d) Heads of the type shown in Figure NE-3326.1-1, sketch (d):

(1) Head thickness t :

$$t = \frac{5PL}{6S} \quad (14)$$

(2) Flange thickness T :

$$T = F + \sqrt{F^2 + J} \quad (15)$$

where F , in. (mm); J , in.² (mm²)

$$F = \frac{PB\sqrt{4L^2 - B^2}}{8S(A - B)} \quad (16)$$

$$J = \left(\frac{M_o}{SB} \right) \left(\frac{A + B}{A - B} \right) \quad (17)$$

NOTE: These equations are approximate in that they do not take into account continuity between the flange ring and the dished head. A more exact method of analysis which takes this into account may be used if it meets the requirements of NE-3200. Such a method may parallel the method of analysis and allowable stresses for flange design in Section III Appendices, Mandatory Appendix XI.

NE-3327 Quick Actuating Closures

Closures other than the multibolted type designed to provide access to the contents space of a component shall have the locking mechanism or locking device so designed that failure of any one locking element or component in the locking mechanism cannot result in the failure of all other locking elements and the release of the closure. Quick actuating closures shall be so designed and installed that it may be determined by visual external observation that the holding elements are in good condition and that their locking elements, when the closure is in the closed position, are in full engagement.

NE-3327.1 Positive Locking Devices. Quick actuating closures that are held in position by positive locking devices and that are fully released by partial rotation or limited movement of the closure itself or the locking mechanism, and any closure that is other than manually operated, shall be so designed that when the vessel is installed the conditions of (a) through (c) below are met.

(a) The closure and its holding elements are fully engaged in their intended operating position before pressure can be built up in the vessel.

(b) Pressure tending to force the closure clear of the vessel will be released before the closure can be fully opened for access.

(c) In the event that compliance with (a) and (b) above is not inherent in the design of the closure and its holding elements, provision shall be made so that devices to accomplish this can be added when the vessel is installed.

NE-3327.2 Other Quick Access and Safety Devices. It is recognized that it is impractical to write detailed requirements to cover the multiplicity of devices used for quick access, or to prevent negligent operation or the circumventing of safety devices. Any device or devices which will provide the safeguards broadly described in NE-3327.1 will meet the intent of this Subsection.

NE-3327.3 Manual Operation. Quick actuating closures that are held in position by a locking device or mechanism that requires manual operation and are so designed that there will be leakage of the contents of the vessel prior to disengagement of the locking elements and release of closure need not satisfy NE-3327.1, but such closures shall be equipped with an audible or visible warning device that will serve to warn the operator if pressure is applied to the vessel before the closure and its holding elements are fully engaged in their intended position and, further, will serve to warn the operator if an attempt is made to operate the locking mechanism or device before the pressure within the vessel is released.

NE-3327.4 Pressure Indicating Device. When installed, all vessels having quick actuating closures shall be provided with a pressure indicating device visible from the operating area.

NE-3328 Combination Units

When a pressure vessel unit consists of more than one independent pressure chamber, operating at the same or different pressures and temperatures, each such chamber shall be designed and constructed to withstand the most severe condition of coincident pressure and temperature expected in normal service. Only the parts of chambers which come within the scope of this Subsection need be constructed in compliance with its provisions.

NE-3330 OPENINGS AND REINFORCEMENT

NE-3331 General Requirements for Openings

(a) For vessels or parts thereof which are not in cyclic service, analysis showing satisfaction of the requirements of NE-3221.1, NE-3221.2, and NE-3221.3, and NE-3221.4 in the immediate vicinity of the openings is not required for pressure loading if the rules of NE-3330 are met.

(b) For vessels or parts thereof which are in cyclic service and do not meet the requirements of NE-3221.5(d) for the specified Service Loads so that a

fatigue analysis is required, the rules contained in NE-3330 assure that the stresses resulting from pressure load satisfy only the requirements of NE-3221.1, NE-3221.2, and NE-3221.3 in the vicinity of openings, and no specific analysis showing satisfaction of those stress limits is required. The requirements of NE-3221.4 may also be considered to be satisfied if, in the vicinity of the nozzle, the stress intensity resulting from external nozzle loads and thermal effects, including gross but not local structural discontinuities, is shown by analysis to be less than $1.5S_m$. In this case, when evaluating the requirements of NE-3221.5(e), the peak stress intensities resulting from pressure loadings may be obtained by application of the stress index method of NE-3338.

(c) The provisions of (a) and (b) above are not intended to restrict the design to any specified section thicknesses or other design details, provided the basic stress limits are satisfied. If it is shown by analysis that all the stress requirements have been met, the rules of NE-3330 are waived.

(d) Openings shall be circular, elliptical, or of any other shape which results from the intersection of a circular or elliptical cylinder with a vessel.

(e) Properly reinforced openings in cylindrical and spherical shells are not limited as to size. Rules regarding metal available for reinforcement are given in NE-3335.

(f) All references to dimensions apply to the finished dimensions, excluding material added as corrosion allowance.

(g) Openings may be located in welded joints.

NE-3332 Reinforcement Requirements for Openings in Shells and Formed Heads

NE-3332.1 Openings Not Requiring Reinforcement. Reinforcement shall be provided in amount and distribution such that the requirements for area of reinforcement are satisfied for all planes through the center of the opening and normal to the surface of the vessel, except that single circular openings need not be provided with reinforcement if the openings have diameters equal to or less than $2\frac{1}{2}$ in. (64 mm).

NE-3332.2 Required Area of Reinforcement. The total cross-sectional area of reinforcement, A , required in any given plane for a vessel under internal pressure shall not be less than:

$$A = dt_r F$$

where

$$A = \text{in.}^2 \text{ (mm}^2\text{)}$$

d = finished diameter of a circular opening or finished dimension (chord length) of an opening on the plane being considered for elliptical and obround openings in corroded condition, in. (mm)

Figure NE-3332.2-1
Chart for Determining Values of F

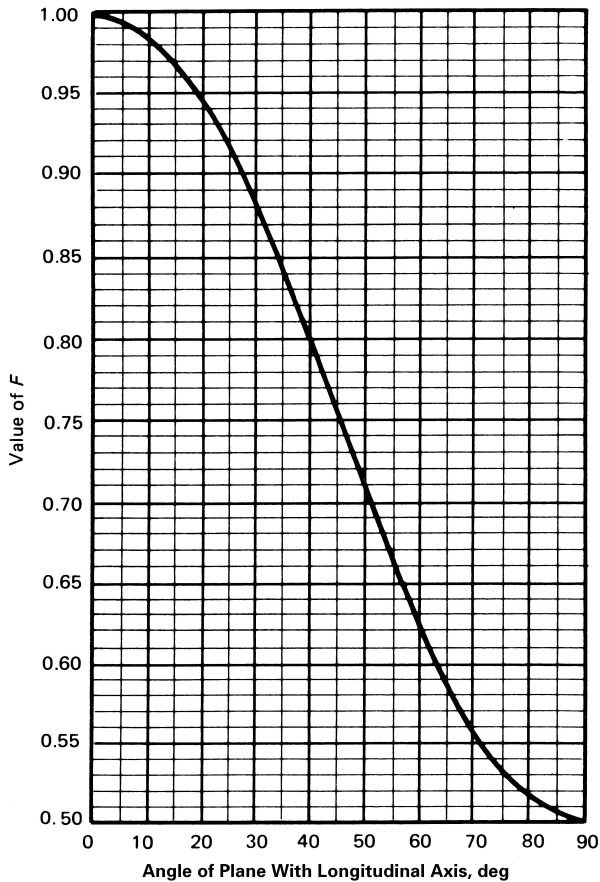

F = a correction factor which compensates for the variation in pressure stresses on different planes with respect to the axis of a vessel. (A value of 1.00 shall be used for all configurations, except that Figure NE-3332.2-1 may be used for integrally reinforced openings in cylindrical shells and cones.)

t_r = the required thickness of a shell or head computed by the rules of this Article for the Design Pressure, in. (mm), except as given in (a), (b), and (c) below:

(a) when the opening and its reinforcement are entirely within the spherical portion of a torispherical head, t_r is the thickness required by NE-3324.8(b) using $M = 1$;

(b) when the opening is in a cone, t_r is the thickness required for a seamless cone of diameter D measured where the nozzle axis pierces the inside wall of the cone;

(c) when the opening and its reinforcement are in an ellipsoidal head and are located entirely within a circle, the center of which coincides with the center of the head and the diameter of which is equal to 80% of the shell diameter, t_r is

the thickness required for a seamless sphere of radius K_1D , where D is the shell diameter and K_1 is given by Table NE-3332.2-1.

At least one-half of the required reinforcing shall be on each side of the centerline of the opening.

NE-3332.4 Reinforcement for External Pressure. The reinforcement required for openings in vessels designed for external pressure need only be 50% of that required in the equation for area in NE-3332.2, except that t_r is the wall thickness required by the rules for components under external pressure.

NE-3332.5 Reinforcement for Both Internal and External Pressure. Reinforcement of vessels subject to both internal and external pressures shall meet the requirements of NE-3332.2 for internal pressure and of NE-3332.4 for external pressure.

NE-3333 Reinforcement Required for Openings in Flat Heads

(a) Flat heads that have an opening with a diameter that does not exceed one-half of the head diameter shall have a total cross-sectional area of reinforcement not less than that given by the formula

$$A = 0.5dt_r$$

where d is as defined in NE-3332.2 and t_r is the thickness in inches which meets the requirements of NE-3325 in the absence of the opening.

(b) As an alternative to (a) above, the thickness of flat heads may be increased to provide the necessary opening reinforcement as follows:

(1) in eq. NE-3325.2(b)(1), by using $2C$ or 0.75 in place of C , whichever is less;

(2) in eq. NE-3325.2(b)(2), by doubling the quantity under the square root sign.

NE-3334 Limits of Reinforcement

The boundaries of the cross-sectional area in any plane normal to the vessel wall and passing through the center of the opening and within which metal shall be located in order to have value as reinforcement are designated as the limits of reinforcement for that plane and are given in the following paragraphs.

NE-3334.1 Limit of Reinforcement Along the Vessel Wall. The limits of reinforcement, measured along the midsurface of the nominal wall thickness, shall meet the following:

(a) One hundred percent of the required reinforcement shall be within a distance on each side of the axis of the opening equal to the greater of the following:

(1) the diameter of the finished opening in the corroded condition;

Table NE-3332.2-1
Values of Spherical Radius Factor K_1

$D/2h$	3.0	2.8	2.6	2.4	2.2	2.0	1.8	1.6	1.4	1.2	1.0
K_1	1.36	1.27	1.18	1.08	0.99	0.90	0.81	0.73	0.65	0.57	0.50

GENERAL NOTE: Equivalent spherical radius = $K_1 D$; $D/2h$ = axis ratio. Interpolation is permitted for intermediate values.

(2) the radius of the finished opening in the corroded condition plus the sum of the thicknesses of the vessel wall and the nozzle wall.

(b) Two-thirds of the required reinforcement shall be within a distance on each side of the axis of the opening equal to the greater of the following:

(1) $r + 0.5\sqrt{Rt}$, where R is the mean radius of shell or head, t is the nominal vessel wall thickness, and r is the radius of the finished opening in the corroded condition;

(2) the radius of the finished opening in the corroded condition plus two-thirds the sum of the thicknesses of the vessel wall and the nozzle wall.

NE-3334.2 Limit of Reinforcement Normal to the Vessel Wall. The limits of reinforcement, measured normal to the vessel wall, shall conform to the contour of the surface at a distance from each surface equal to the following limits as shown in [Figure NE-3334.2-1](#) and specified in (a), (b), and (c) below.

(a) For [Figure NE-3334.2-1](#), sketches (a), (b), (d), and (e):

where $L \geq 2.5t_n$, the limit of reinforcement equals the larger of

$$0.5\sqrt{r_m t_n} + 0.5r_2 \quad \text{or} \quad 2.5t_n$$

where $L < 2.5t_n$, the limit of reinforcement equals

$$0.5\sqrt{r_m t_n} + 0.5r_2$$

where

L = length of thickened portion of nozzle neck for sketches (a), (b), (e), in. (mm), or length of nozzle for sketch (d), in. (mm)

r_2 = transition radius between nozzle and wall, in. (mm)

r_i = inside radius, in. (mm)

r_m = mean radius = $r_i + 0.5t_n$

t_n = nominal nozzle thickness, as indicated, in. (mm)

For the case of a nozzle with a tapered inside diameter, the limit shall be obtained by using r_i and t_n values at the nominal outside diameters of the vessel wall [[Figure NE-3334.2-1](#), sketch (e)].

(b) For [Figure NE-3334.2-1](#), sketches (c) and (f):

$$\text{limit of reinforcement} = 0.5\sqrt{r_m t_n}$$

where

r_i = inside radius, in. (mm)

$r_m = r_i + 0.5 t_n$

$t_n = t_p + 0.667X$

t_p = nominal thickness of the attached pipe, in. (mm)

X = slope offset distance, in. (mm)

θ = angle between vertical and slope, 45 deg or less

For the case of a nozzle with a tapered inside diameter, the limit shall be obtained by using r_i and t_n values at the center of gravity of nozzle reinforcement area. These values must be determined by a trial and error procedure [[Figure NE-3334.2-1](#), sketch (f)].

(c) When reinforcing pads or insert plates are used, the limits of reinforcement, measured normal to the vessel wall, shall conform to the contour of the surface at a distance from each surface equal to $(0.5\sqrt{r_m t_n} + t_e)$ or $(2.5t_n + t_e)$, whichever is larger, where r_m is the mean nozzle radius, t_n is the nozzle thickness, and t_e is equal to the thickness of any added reinforcement or 1.5 times the vessel wall thickness, whichever is smaller.

NE-3335 Metal Available for Reinforcement

Metal may be counted as contributing to the area of reinforcing called for in [NE-3332](#), provided it lies within the limits of reinforcement specified in [NE-3334](#) and shall be limited to material which meets the following requirements:

(a) metal forming a part of the vessel wall which is in excess of that required in accordance with [NE-3130](#) and is exclusive of corrosion allowance;

(b) similar excess metal in the nozzle wall, provided the nozzle is integral with the vessel wall or is joined to it by a full penetration weld;

(c) weld metal which is fully continuous with the vessel wall;

(d) the mean coefficient of thermal expansion of metal to be included as reinforcement under (b) or (c) above shall be within 15% of the value of the vessel wall material;

(e) metal not fully continuous with the shell, as that in nozzles attached by partial penetration welds on only one side, shall not be counted as reinforcement;

(f) metal available for reinforcement shall not be considered as applying to more than one opening;

(g) not less than one-half the required material shall be on each side of the center line of the opening.

**Figure NE-3334.2-1
Nozzle Dimensions**

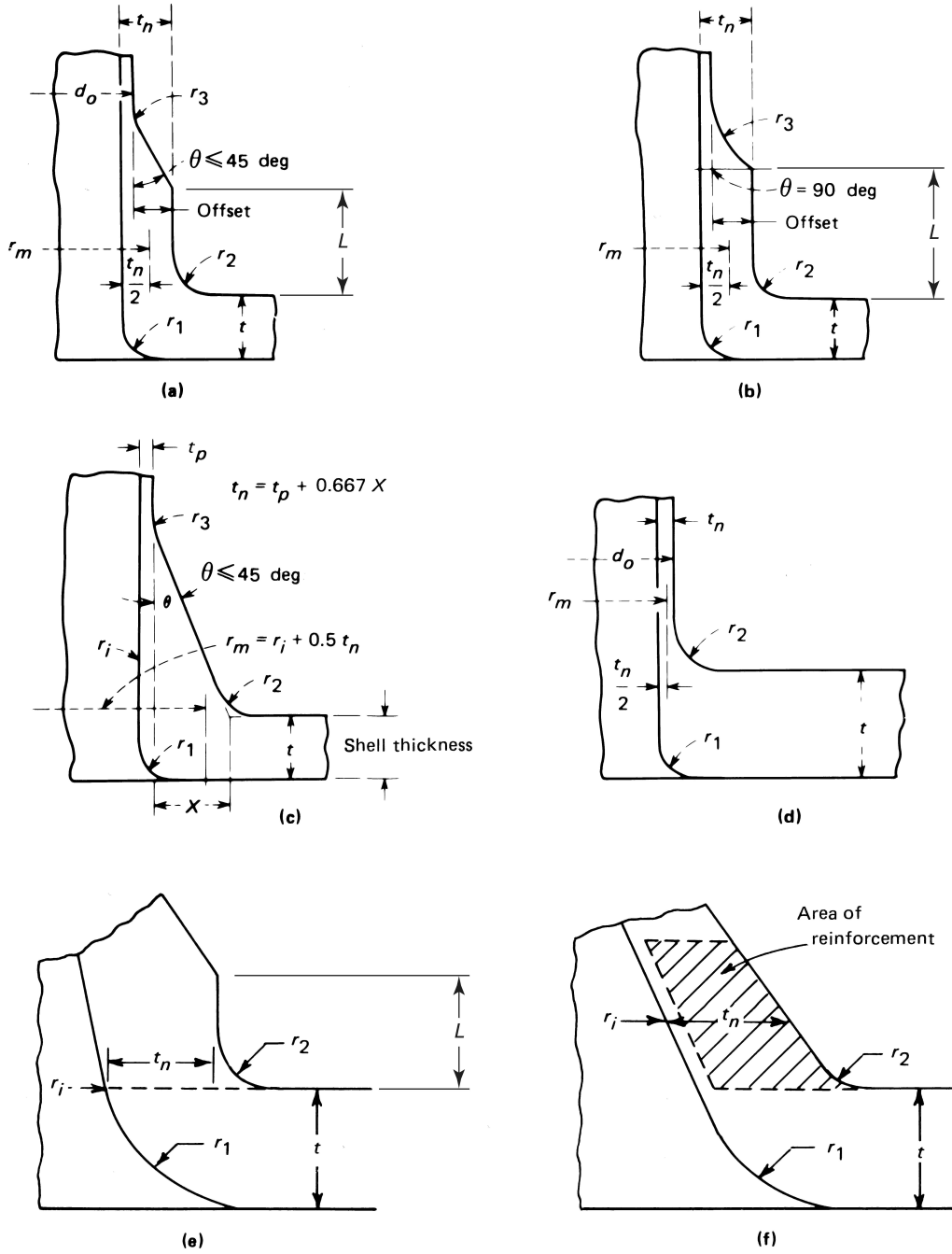
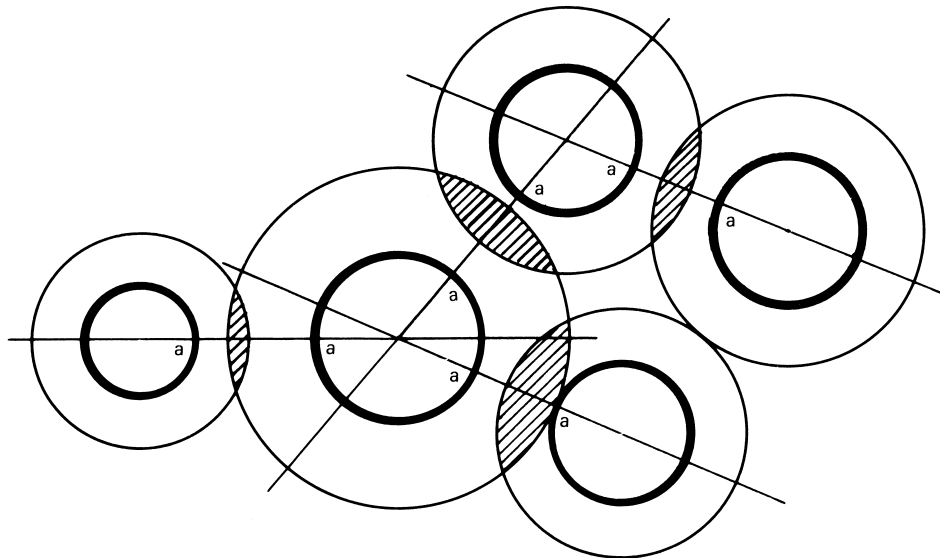

Figure NE-3335.1-1
Arrangement of Multiple Openings



GENERAL NOTES:

- (a) Hatched area represents overlapping of the reinforcement limits.
- (b) Each cross section indicated by a straight line a-a must be investigated for adequacy of reinforcement.
- (c) Heavy circles represent openings, and light circles represent limits of reinforcement.

NE-3335.1 Reinforcement of Multiple Openings.

(a) When any two openings in a group of two or more openings are spaced at less than two times their average diameter so that their limits of reinforcement overlap, the two openings shall be reinforced in the plane connecting the centers (Figure NE-3335.1-1), in accordance with NE-3330 through NE-3336, with a combined reinforcement that has an area equal to the combined area of the reinforcements required for separate openings. No portion of the cross section is to be considered as applying to more than one opening, or to be evaluated more than once in a combined area. The following requirements shall also apply.

(1) When the distance between the centers of the openings is greater than $1\frac{1}{3}$ times their average diameter, the area of reinforcement between them shall be not less than 50% of the total required for these openings.

(2) When the distance between the centers of the openings is less than $1\frac{1}{3}$ times their average diameter, no credit for reinforcement shall be taken for any of the material between these openings, and the openings shall be reinforced as described in (b) below.

(b) Any number of adjacent openings, in any arrangement, may be reinforced for an assumed opening of a diameter enclosing all such openings. The diameter of the assumed opening shall not exceed the following:

(1) for vessels 60 in. (1 500 mm) diameter and less, one-half the vessel diameter, but not to exceed 20 in. (500 mm);

(2) for vessels over 60 in. (1 500 mm) diameter, one-third the vessel diameter, but not to exceed 40 in. (1 000 mm)

(c) When a group of openings is reinforced by a thicker section butt welded into the shell or head, the edges of the inserted section shall be tapered as prescribed in NE-3361.

NE-3336 Strength of Reinforcing Material

Material used for reinforcement shall be preferably the same as that of the vessel wall. If the material of the nozzle wall or reinforcement has a lower design stress value S than the vessel material, the amount of area provided by the nozzle wall or reinforcement in satisfying the requirements of NE-3332 shall be taken as the actual area provided multiplied by the ratio of the nozzle or reinforcement design stress value to the vessel material design stress value. No reduction in the reinforcing required may be taken for the increased strength of reinforcing material and weld metal having higher design stress values than that of the material of the vessel wall. Deposited weld metal outside of either the vessel wall or any reinforcing pad used as reinforcement shall be credited with an allowable stress value equivalent to the weaker of the materials connected by the weld. Vessel-

to-nozzle or pad-to-nozzle attachment weld metal within the vessel wall or within the pad may be credited with a stress value equal to that of the vessel wall or pad, respectively.

NE-3336.1 Strength of Weld. On each side of the plane defined in NE-3334, the strength of the attachment joining the vessel wall and reinforcement or any two parts of the attached reinforcement shall be at least equal to the lesser of (a) or (b) below:

(a) the strength in tension of the cross section of the element of reinforcement being considered; or

(b) the strength in tension of the area defined in NE-3332 less the strength in tension of the reinforcing area which is integral in the vessel wall.

NE-3336.2 Strength of Attachment. The strength of the attachment joint shall be considered for its entire length on each side of the plane of the area of reinforcement defined in NE-3334. For obround openings, consideration shall also be given to the strength of the attachment joint on one side of the plane transverse to the parallel sides of the opening which passes through the center of the semicircular end of the opening.

NE-3338 Pressure Stresses in Openings for Fatigue Evaluation Under Operating Conditions

NE-3338.1 General. For the purpose of determining peak stresses around the opening, three acceptable methods are listed below.

(a) *Analytical Method.* This method uses suitable analytical techniques such as finite element computer analyses, which provide detailed stress distributions around openings. In addition to peak stresses due to pressure, the effects of other loadings shall be included. The total peak stress at any given point shall be determined by combining stresses due to pressure, thermal, and external loadings in accordance with the rules of NE-3200.

(b) *Experimental Stress Analysis.* This is based on data from experiments (Section III Appendices, Mandatory Appendix II).

(c) *Stress Index Method.* This uses various equations together with available data obtained from an extensive series of tests covering a range of variation of applicable dimensional ratios and configurations (NE-3338.2). This method covers only single, isolated openings. Stress indices may also be determined by theoretical or experimental stress analysis.

NE-3338.2 Stress Index Method.

(a) The term *stress index*, as used herein, is defined as the numerical ratio of the stress components σ_v , σ_n , and σ_r under consideration to the computed membrane stress in the unpenetrated vessel material. However, the material which increases the thickness of a vessel wall locally at the nozzle shall not be included in the calculations of these stress components. When the thickness of the vessel

wall is increased over that required to the extent provided hereinafter, the values of r_1 and r_2 in Figure NE-3334.2-1 shall be referred to the thickened section.

(b) The symbols for the stress components are shown in Figure NE-3338.2-1 and are defined as follows:

S = the stress intensity (combined stress) at the point under consideration, psi (MPa)

σ_n = the stress component normal to the plane of the section (ordinarily the circumferential stress around the hole in the shell), psi (MPa)

σ_r = the stress component normal to the boundary of the section, psi (MPa)

σ_t = the stress component in the plane of the section under consideration and parallel to the boundary of the section, psi (MPa)

(c) When the conditions of (d) below are satisfied, the stress indices of Table NE-3338.2(c)-1 may be used for nozzles designed in accordance with the applicable rules of NE-3330. These stress indices deal only with the maximum stresses, at certain general locations, due to internal pressure. In the evaluation of stresses in or adjacent to vessel openings and connections, it is often necessary to consider the effect of stresses due to external loadings or thermal stresses. In such cases, the total stress at a given point may be determined by superposition. In the case of combined stresses due to internal pressure and nozzle loading, the maximum stresses for a given location should be considered as acting at the same point and added algebraically, unless positive evidence is available to the contrary.

(d) The indices of Table NE-3338.2(c)-1 apply when the conditions stipulated in (1) through (6) below exist.

(1) The opening is for a circular nozzle whose axis is normal to the vessel wall. If the axis of the nozzle makes an angle φ with the normal to the vessel wall and if $d/D \leq 0.15$, an estimate of the σ_n index on the inside may be obtained from one of the following equations.

For hillside connections in spheres or cylinders:

$$K_2 = K_1 (1 + 2 \sin^2 \varphi)$$

For lateral connections in cylinders:

$$K_2 = K_1 [1 + (\tan \varphi)^{4/3}]$$

where

K_1 = the σ_n inside stress index of Table NE-3338.2(c)-1 for a radial connection

K_2 = the estimated σ_n inside stress index for the nonradial connection

Figure NE-3338.2-1
Direction of Stress Components

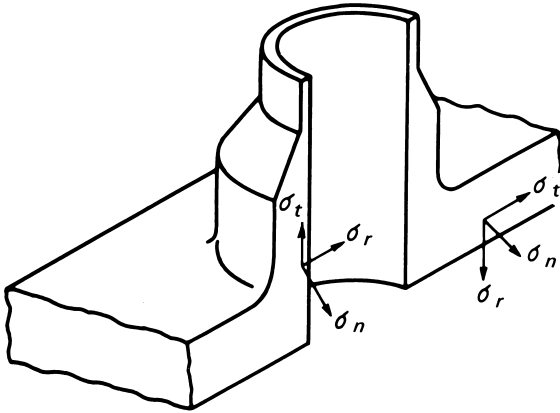

Table NE-3338.2(c)-1
Stress Indices for Nozzles

Nozzles in Spherical Shells and Formed Heads				
Stress	Inside Corner	Outside Corner		
σ_n	2.0	2.0		
σ_t	-0.2	2.0		
σ_r	$-2t_n/R$	0		
S	2.2	2.0		
Nozzles in Cylindrical Shells				
Stress	Longitudinal Plane		Transverse Plane	
	Inside	Outside	Inside	Outside
σ_n	3.1	1.2	1.0	2.1
σ_t	-0.2	1.0	-0.2	2.6
σ_r	$-t_n/R$	0	$-t_n/R$	0
S	3.3	1.2	1.2	2.6

(2) The arc distance measured between the center lines of adjacent nozzles along the inside surface of the shell is not less than three times the sum of their inside radii for openings in a head or along the longitudinal axis of a shell and is not less than two times the sum of their radii for openings along the circumference of a cylindrical shell.

(3) The following dimensional ratios are met:

Ratio	Cylinder	Sphere
$\frac{\text{Inside shell diameter}}{\text{Shell thickness}} = \frac{D}{t}$	10 to 100	10 to 100
$\frac{\text{Inside nozzle diameter}}{\text{Inside shell diameter}} = \frac{d}{D}$	0.5, max.	0.5, max.
$\frac{d}{\sqrt{Dt}}$...	0.8, max.
$d/\sqrt{Dt_n r_2 / t}$	1.5, max.	...

In the case of cylindrical shells, the total nozzle reinforcement area on the transverse axis of the connections, including any outside of the reinforcement limits, shall not exceed 200% of that required for the longitudinal axis (compared to 50% permitted by Figure NE-3332.2-1), unless a tapered transition section is incorporated into the reinforcement and the shell, meeting the requirements of NE-3361.

(4) The inside corner radius r_1 (Figure NE-3334.2-1) is between 10% and 100% of the shell thickness t .

(5) The outer corner radius r_2 (Figure NE-3334.2-1) is large enough to provide a smooth transition between the nozzles and the shell. In addition, for opening diameters greater than $1\frac{1}{2}$ times the shell thickness in cylindrical shells and 2:1 ellipsoidal heads and greater than three shell thicknesses in spherical shells, the value of r_2 shall not be less than one-half the thickness of the shell or nozzle wall, whichever is greater.

(6) The radius r_3 (Figure NE-3334.2-1) is not less than the greater of the following:

(-a) $0.002\theta d_o$ where d_o is the outside diameter of the nozzle and is as shown in Figure NE-3334.2-1 and the angle θ is expressed in degrees;

(-b) $2(\sin \theta)^3$ times offset for the configuration shown in Figure NE-3334.2-1, sketches (a) and (b).

Figure NE-3351-1
Welded Joint Locations Typical of Categories A, B, C, and D

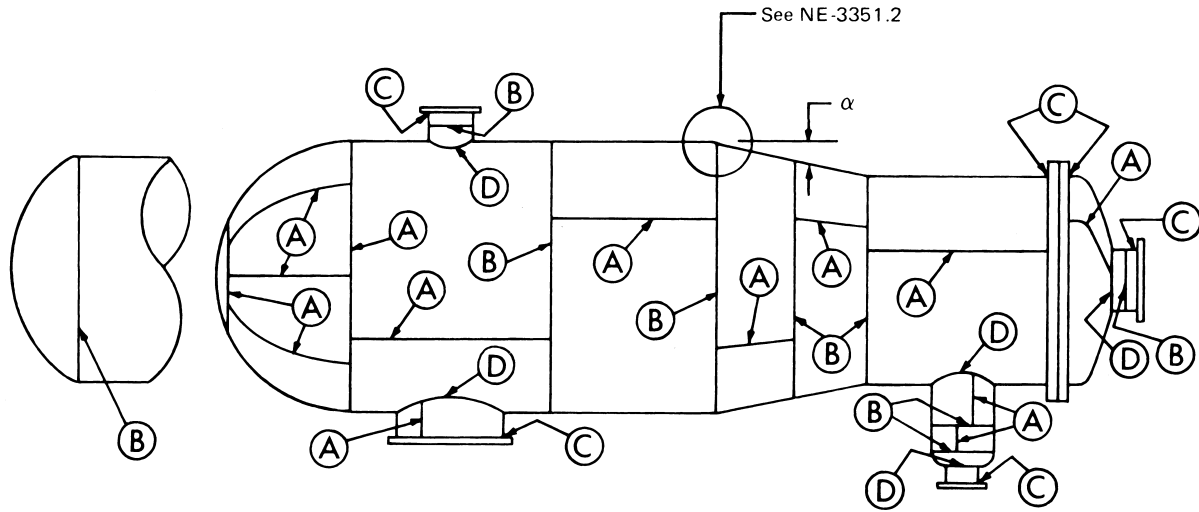

NE-3350 DESIGN OF WELDED CONNECTIONS

NE-3351 Welded Joint Categories

The term *Category* as used herein defines the location of a joint in a vessel but not the type of joint. The categories established by this paragraph are for specifying special requirements regarding joint type and degree of examination for certain welded pressure joints. Since these special requirements, which are based on service, material, and thickness, do not apply to every welded joint, only those joints to which special requirements apply are included in the categories. The special requirements will apply to joints of a given category only when specifically stated. The joints included in each category are designated as joints of Categories A, B, C, and D. [Figure NE-3351-1](#) illustrates typical joint locations included in each category.

NE-3351.1 Category A. Category A comprises longitudinal welded joints within the main shell or communicating chambers⁹ transitions in diameter or nozzles; welded joints within a sphere, within a formed or flat head, or within the side plates¹⁰ of a flat-sided vessel; circumferential welded joints connecting hemispherical heads to main shells, to transitions in diameters, to nozzles, or to communicating chambers.

NE-3351.2 Category B. Category B comprises circumferential welded joints within the main shell or communicating chambers⁹ nozzles or transitions in diameter including joints between the transition and a cylinder at either the large or small end; or circumferential welded joints connecting formed heads other than hemispherical to main shells, transitions in diameter, nozzles, or communicating chambers.

NE-3351.3 Category C. Category C comprises welded joints connecting flanges, Van Stone laps, tube sheets, or flat heads to the main shell, formed heads, transitions in diameter, nozzles, or communicating chambers⁹ any welded joint connecting one side plate¹⁰ to another side plate of a flat-sided vessel.

NE-3351.4 Category D. Category D comprises welded joints connecting communicating chambers⁹ or nozzles to main shells, spheres, transitions in diameter, heads, or flat-sided vessels, and those joints connecting nozzles to communicating chambers. For nozzles at the small end of a transition in diameter, see Category B.

NE-3352 Permissible Types of Welded Joints

The design of the vessel shall meet the requirements for each category of joint. Butt joints are full penetration joints between plates or other elements that lie approximately in the same plane. Category B angle joints between plates or other elements that have an offset angle α not exceeding 30 deg are considered as meeting the requirements for butt joints. [Figure NE-3352-1](#) shows typical butt welds for each category joint.

NE-3352.1 Joints of Category A. All welded joints of Category A as defined in [NE-3351](#) shall meet the fabrication requirements of [NE-4241](#) and shall be capable of being examined in accordance with [NE-5210](#).

NE-3352.2 Joints of Category B.

(a) All welded joints of Category B as defined in [NE-3351](#) shall meet the fabrication requirements of [NE-4242](#) and shall be capable of being examined in accordance with [NE-5220](#).

**Figure NE-3352-1
Typical Butt Joints**

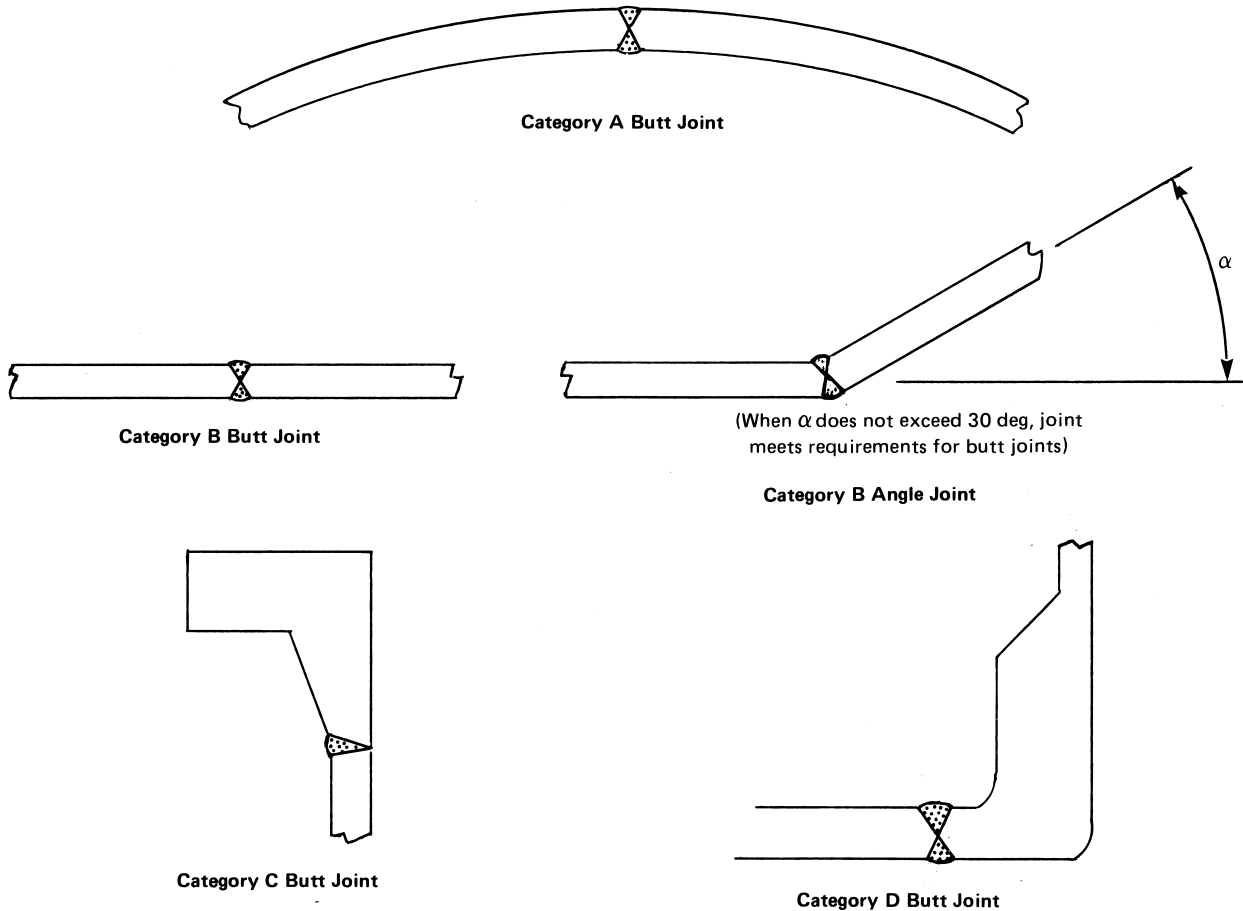

(b) Surface examination in accordance with NE-5280(b) may be substituted for radiographic examination required in NE-5221 for Category B butt welds in electrical penetration assemblies subject to the following limitations:

(1) The allowable stress for the weld joint shall be multiplied by a factor of 0.8.

(2) P-No. 1 base materials shall be used for construction.

NE-3352.3 Joints of Category C. All welded joints of Category C as defined in NE-3351 shall meet the fabrication requirements of NE-4243 and shall be capable of being examined in accordance with NE-5230. The minimum dimensions of Figure NE-4243-1 and Figure NE-4243-2 shall be met where

$$\begin{aligned} t, t_n &= \text{nominal thickness, in. (mm)} \\ t_c &= 0.7t_n \text{ or } \frac{1}{4} \text{ in. (6 mm), whichever is less} \\ t_w &= \text{the lesser of } t_n \text{ or } t/2 \end{aligned}$$

NE-3352.4 Joints of Category D. All welded joints of Category D as defined in NE-3351 shall be in accordance with the requirements of NE-3359 and one of (a) through (f) below.

(a) *Butt-Welded Nozzles.* Nozzles shall meet the fabrication requirements of NE-4244(a) and shall be capable of being examined in accordance with NE-5241. The minimum dimensions and geometrical requirements of Figure NE-4244(a)-1 shall be met where:

$$\begin{aligned} r_1 &= \frac{1}{4}t \text{ or } \frac{3}{4} \text{ in. (19 mm), whichever is less} \\ r_2 &= \frac{1}{4} \text{ in. (6 mm) min.} \\ t &= \text{nominal thickness of part penetrated, in. (mm)} \\ t_n &= \text{nominal thickness of penetrating part, in. (mm)} \end{aligned}$$

(b) *Full Penetration Corner-Welded Nozzles.* Nozzles shall meet the fabrication requirements of NE-4244(b) and shall be capable of being examined as required in NE-5242. Inserted-type nozzles having added reinforcement in the form of a separate reinforcing plate shall be attached by welds at the outer edge of the reinforcement

plate and at the nozzle periphery. The weld at the outer edge of the reinforcement shall be a fillet weld with a minimum throat dimension of $\frac{1}{2}t_{\min}$. The minimum dimensions of [Figure NE-4244\(b\)-1](#) shall be met where:

$$\begin{aligned} r_1 &= \frac{1}{4}t \text{ or } \frac{3}{4} \text{ in. (19 mm), whichever is less} \\ r_2 &= \frac{1}{4} \text{ in. (6 mm) min.} \\ t &= \text{nominal thickness of part penetrated, in. (mm)} \\ t_c &= 0.7t_n \text{ or } \frac{1}{4} \text{ in. (6 mm), whichever is less} \\ t_e &= \text{thickness of reinforcing element, in. (mm)} \\ t_n &= \text{nominal thickness of penetrating part, in. (mm)} \\ t_{\min} &= \text{the smaller of } \frac{3}{4} \text{ in. (19 mm) or the thickness of} \\ &\quad \text{the thinner of the parts joined} \end{aligned}$$

(c) *Use of Deposited Weld Metal for Openings and Nozzles*

(1) Nozzles shall meet the requirements of [NE-4244\(c\)](#) and shall be capable of being examined in accordance with [NE-5244](#).

(2) When the deposited weld metal is used as reinforcement, the coefficients of thermal expansion of the base metal, the weld metal, and the nozzle shall not differ by more than 15% of the lowest coefficient involved.

(3) The minimum dimensions of [Figure NE-4244\(c\)-1](#) shall be met where:

$$\begin{aligned} r_1 &= \frac{1}{4}t \text{ or } \frac{3}{4} \text{ in. (19 mm), whichever is less} \\ t &= \text{nominal thickness of part penetrated, in. (mm)} \\ t_c &= 0.7t_n \text{ or } \frac{1}{4} \text{ in. (6 mm), whichever is less} \\ t_n &= \text{nominal thickness of penetrating part, in. (mm)} \end{aligned}$$

(4) The corners of the end of each nozzle extending less than $\sqrt{dt_n}$ beyond the inner surface of the part penetrated shall be rounded to a radius of one-half the thickness t_n of the nozzle or $\frac{3}{4}$ in. (19 mm), whichever is smaller.

(d) *Attachment of Nozzles Using Partial Penetration Welds*

(1) *Welded From Both Sides*

(-a) Partial penetration welds used to connect nozzles from both sides shall meet the requirements of [NE-4244\(d\)](#). Typical details are shown in [Figure NE-4244\(d\)-1](#). For inserted nozzles without reinforcing elements, two partial penetration welds may be used of any desired combination of fillet, single bevel, and single J-welds. Inserted-type nozzles having added reinforcement in the form of a separate reinforcing plate are not permitted with partial penetration welding.

(-b) The minimum dimensions of [Figure NE-4244\(d\)-1](#) shall be met where:

$$\begin{aligned} c &= \frac{1}{2}t_{\min} \\ t &= \text{nominal thickness of part penetrated, in. (mm)} \\ t_1 \text{ or } t_2 &= \text{not less than the smaller of } \frac{1}{4} \text{ in. (6 mm) or} \\ &\quad 0.7t_{\min} \\ t_1 + t_2 &= 1\frac{1}{4}t_{\min} \end{aligned}$$

$$\begin{aligned} t_c &= 0.7t_n \text{ or } \frac{1}{4} \text{ in. (6 mm), whichever is less} \\ t_{\min} &= \text{the smaller of } \frac{3}{4} \text{ in. (19 mm) or the thickness} \\ &\quad \text{of the thinner of the parts joined} \\ t_n &= \text{nominal thickness of penetrating part, in. (mm)} \\ t_w &= 0.7t_n \end{aligned}$$

(2) *Welded From One Side*

(-a) Partial penetration welds used to connect nozzles from one side are allowed only for attachments on which there are no piping reactions. They shall meet the fabrication requirements of [NE-4244\(d\)](#) and shall be capable of being examined in accordance with the requirements of [NE-5242](#).

(-b) The minimum dimensions of [Figure NE-4244\(d\)-2](#) shall be met where:

$$\begin{aligned} c &= \text{diametral clearance between nozzle and vessel} \\ &\quad \text{penetration, in. (mm)} \\ &= 0.010 \text{ in. (0.25 mm) for } d \leq 1 \text{ in. (25 mm)} \\ &= 0.020 \text{ in. (0.50 mm) for } 1 < d \leq 4 \text{ in. (100 mm) and} \\ &= 0.030 \text{ in. (0.75 mm) for } d > 4 \text{ in. (100 mm) max.,} \\ &\quad \text{except that the above limits on maximum clearance} \\ &\quad \text{need not be met for the full length of the opening,} \\ &\quad \text{provided there is a region at the weld preparation} \\ &\quad \text{and a region near the end of the opening opposite} \\ &\quad \text{the weld which does meet the above limits on} \\ &\quad \text{maximum clearance and the latter region is exten-} \\ &\quad \text{sive enough (not necessarily continuous) to} \\ &\quad \text{provide a positive stop for nozzle deflection} \\ d &= \text{outside diameter of nozzle [or of the inner cylinder} \\ &\quad \text{as shown in } \text{Figure NE-4244(d)-3], in. (mm)} \\ r_1 &= \frac{1}{4}t_n \text{ or } \frac{3}{4} \text{ in. (19 mm), whichever is less} \\ r_2 &= \frac{1}{16} \text{ in. (1.5 mm) min.} \\ r_3 &= r_2 \text{ or equivalent chamfer, min.} \\ r_4 &= \frac{1}{2}t_n \text{ or } \frac{3}{4} \text{ in. (19 mm), whichever is smaller} \\ t &= \text{nominal thickness of part penetrated, in. (mm)} \\ t_c &= 0.7t_n \text{ or } \frac{1}{4} \text{ in. (6 mm), whichever is less} \\ t_n &= \text{nominal thickness of penetrating part [or the lesser} \\ &\quad \text{of } t_{n1} \text{ or } t_{n2} \text{ in } \text{Figure NE-4244(d)-2], in. (mm)} \\ \lambda &= \frac{1}{16} \text{ in. (1.5 mm) min.} \\ \lambda &= t_n \text{ max.} \end{aligned}$$

(3) The corners to the end of each nozzle extending less than $\sqrt{dt_n}$ beyond the inner surface of the part penetrated shall be rounded to a radius of one-half of the thickness t_n of the penetrating part or $\frac{3}{4}$ in. (19 mm), whichever is smaller.

(4) Weld groove design for partial penetration joints attaching nozzles may require special consideration to achieve the minimum depth of weld and adequate access for welding examination. The welds shown in the sketches of [Figure NE-4244\(d\)-2](#) and [Figure NE-4244\(d\)-3](#) may be on either the inside or the outside of the shell. Weld preparation may be J-groove as shown in the figures or straight bevel.

(e) *Attachment of Fittings with Internal Threads.* (Written for fittings with internal threads but also applicable to externally threaded and socket welded or butt-welded fittings.) The attachment of internally threaded fittings shall meet the requirements of (1) through (3) below.

(1) Except as provided for in (2) and (3) below, the provisions of NE-4244(e) shall be met. The minimum weld dimensions shall be as shown in Figure NE-4244(e)-1 where:

$$t_c = \frac{1}{4} \text{ in. (6 mm), min.}$$

$$t_{\min} = \text{lesser of } \frac{3}{4} \text{ in. (19 mm) or the thickness of the parts joined}$$

Details in sketches (a) and (b):

$$t_1 + t_2 = 1\frac{1}{4} t_{\min}$$

Detail in sketch (c):

$$t_w = \text{thickness of Sch. 160 pipe (ASME B36.10M), in. (mm)}$$

$$t_1 + t_2 = \text{not less than smaller of } \frac{1}{4} \text{ in. (6 mm) or } 0.7t_{\min}$$

Detail in sketch (d):

$$c = \frac{1}{2}t_{\min}$$

$$t_w = 0.7t_{\min}$$

(2) Fittings shown in Figure NE-4244(e)-1 sketches (a-2), (b-2), (c-2), and (d) not exceeding NPS 2 (DN 50) may be attached by welds that are exempt from size requirements other than those specified in NE-3359.

(3) Openings

(-a) When internally threaded fittings and bolting pads not exceeding NPS 3 (DN 80) are attached to vessels having a wall thickness not greater than $\frac{3}{8}$ in. (10 mm) by a fillet weld deposited from the outside only, the welds shall comply with the dimensions shown in Figure NE-4244(e)-2. These openings do not require reinforcement other than that inherent in the construction as permitted in NE-3332.1.

(-b) If the opening exceeds NPS 5 (DN 125), it shall be reinforced in accordance with NE-3332 with the nozzle or other connections attached, using a suitable detail in Figure NE-4244(e)-1.

(f) *Attachment of Tubed Connections.* Tubes recessed into thick walled vessels or headers, welded from only one side, shall have a welding groove in the vessel wall not deeper than t_n on the longitudinal axis of the opening. A recess $\frac{1}{16}$ in. (1.5 mm) deep shall be provided at the bottom of the groove in which to center the nozzle. The dimension t_w of the attachment weld shall not be less than t_n nor less than $\frac{1}{4}$ in. (6 mm). The minimum dimension for t_c shall be $\frac{1}{4}$ in. (6 mm) [Figure NE-4244(f)-1, sketches (a) and (b)].

NE-3355 Welding Grooves

The dimensions and shape of the edges to be joined shall be such as to permit complete fusion and penetration, except as otherwise permitted in NE-3352.4.

NE-3356 Fillet Welds

(a) Corner or T-joints for Category C welds may be made with fillet welds, provided the attachment is properly supported independently of such welds. Closures which meet the requirements of NE-3367 may be attached by fillet welds.

(b) The allowable load on fillet welds shall equal the product of the weld area based on minimum leg dimension, the allowable stress value in tension of the material being welded, and the factor 0.55.

(c) Except where specific details are permitted in other paragraphs, welded joints subject to bending stresses shall have fillet welds added where necessary to reduce stress concentration. Corner joints, with fillet welds only, shall not be used unless the plates forming the corner are properly supported independently of such welds.

NE-3358 Design Requirements for Head Attachments

NE-3358.1 Skirt Length of Formed Heads.

(a) Ellipsoidal and other types of formed heads, concave or convex to the pressure, shall have a skirt length not less than that shown in Figure NE-3358.1(a)-1. Heads that are fitted inside or over a shell shall have a driving fit before welding.

(b) A tapered transition, having a length not less than three times the offset between the adjacent surfaces of abutting sections as shown in Figure NE-3358.1(a)-1, shall be provided at joints between formed heads and shells that differ in thickness by more than one-fourth the thickness of the thinner section or by more than $\frac{1}{8}$ in. (3 mm), whichever is less. When a taper is required on any formed head thicker than the shell and intended for butt-welded attachment [Figure NE-3358.1(a)-1], the skirt shall be long enough so that the required length of taper does not extend beyond the tangent line.

NE-3358.2 Unstayed Flat Heads Welded to Shells. The requirements for the attachment of unstayed flat heads welded to shells are given in NE-3325, NE-3358.3, and NE-3358.4.

NE-3358.3 Head Attachments Using Corner Joints. When shells, heads, or other pressure parts are welded to a forged or rolled plate to form a corner joint, as in Figures NE-4243-1 and NE-4243-2, the joint shall meet the requirements of (a) through (e) below.

(a) On the cross section through the welded joint, the line of fusion between the weld metal and the forged or rolled plate being attached shall be projected on planes both parallel to and perpendicular to the surface of the plate being attached, in order to determine the dimensions a and b , respectively.

**Figure NE-3358.1(a)-1
Heads Attached to Shells**

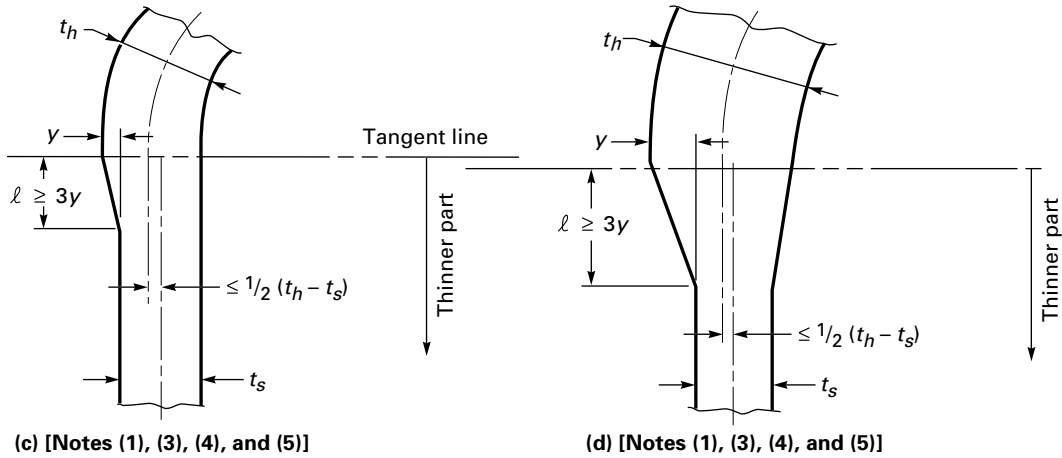
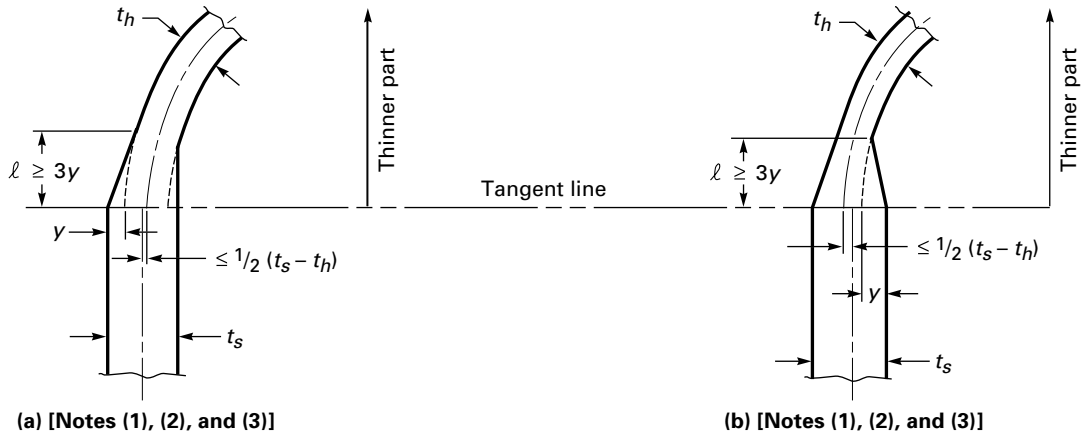

NOTES:

- (1) Length of required taper ℓ may include the width of the weld.
- (2) In all cases, the projected length of taper ℓ shall be not less than $3y$.
- (3) The shell plate center line may be on either side of the head plate center line.
- (4) In all cases, ℓ shall be not less than 3 times y when t_h exceeds $1.25t_s$; minimum length of skirt is $3t_h$, but need not exceed $1\frac{1}{2}$ in. (38 mm) except when necessary to provide required length of taper.
- (5) When t_h is equal to or less than $1.25t_s$, length of skirt shall be sufficient for any required taper.

(b) For flange rings of bolted flanged connections, and for flat heads with a projection having holes for a bolted connection, the sum of a and b shall not be less than three times the nominal wall thickness of the abutting pressure part.

(c) For other components, the sum of a and b shall not be less than two times the nominal wall thickness of the abutting pressure part. Examples of such components are flat heads without a projection having holes for a bolted connection and the side plates of a rectangular vessel.

(d) Other dimensions at the joint shall be in accordance with details as shown in [Figures NE-4243-1](#) and [NE-4243-2](#) where:

(1) In [Figure NE-4243-1](#):

sketch (a)

$a + b$ not less than $2t_s$

$(b = 0)$

t_w not less than t_s

t_s = actual thickness of shell, in. (mm)

sketch (b)

$a + b$ not less than $2t_s$

t_w not less than t_s

t_p not less than t_s

t_s = actual thickness of shell

sketch (c)

$a + b$ not less than $2t_s$

a not less than t_s

t_p not less than t_s

t_s = actual thickness of shell

sketch (d)

$a + b$ not less than $2t_s$

a not less than t_s

t_p not less than t_s

t_s = actual thickness of shell

sketch (e)

$a + b$ not less than $2t_s$

$(b = 0)$

t_s = actual thickness of shell

sketch (f)

$a + b$ not less than $2t_s$

t_s = actual thickness of shell

sketch (g)

$a + b$ not less than $2t_s$

a_1 not less than $0.5a_2$ nor greater than $2a_2$

$a_1 + a_2 = a$

t_s = actual thickness of shell

sketch (h)

a not less than $3t_n$

$(b = 0)$

c not less than t_n or t_D , whichever is less (t_n and t_D are defined in Section III Appendices, Mandatory Appendix XI, XI-3130)

sketch (i)

$a + b$ not less than $3t_n$

c not less than t_n or t_D , whichever is less (t_n and t_D are defined in Section III Appendices, Mandatory Appendix XI, XI-3130)

(2) In [Figure NE-4243-2](#):

For forged tubesheets, forged flat heads, and forged flanges with the weld preparation bevel angle not greater than 45 deg measured from the face:

t, t_n = nominal thickness of welded parts, in. (mm)

$t_c = 0.7t_n$ or $1/4$ in. (6 mm), whichever is less

t_w = the lesser of $t_n/2$ or $t/4$

For all other material forms and for forged tubesheets, forged flat heads, and forged flanges with the weld preparation bevel angle greater than 45 deg measured from the face:

t, t_n = nominal thicknesses of welded parts, in. (mm)

$t_n = 0.7t_n$ or $1/4$ in. (6 mm), whichever is less

t_w = the lesser of t_n or $t/2$

(e) Joint details that have a dimension through the joint less than the thickness of the shell, head, or other pressure part, or that provide attachment eccentric thereto, are not permissible [[Figure NE-4243-1](#), sketches (j), (k), and (l)].

NE-3358.4 Flat Heads With Hubs. Hubs for butt welding as shown in [Figure NE-4243.1-1](#) shall have the following minimum dimensions:

sketch (a)

r not less than $1.5t_s$

sketch (b)

r not less than $1.5t_s$

e not less than t_s

sketch (c)

h not less than $1.5t_s$

sketch (d)

t_f not less than $2t_s$

r not less than $3t_f$

sketch (e)

t_f not less than $2t_s$

r not less than $3t_f$

e not less than t_f

NE-3359 Design Requirements for Nozzle Attachment Welds

In addition to the requirements of [NE-3352.4](#), the minimum design requirements for nozzle attachment welds shall be as stipulated in (a) and (b) below.

(a) *Required Weld Strength.* Sufficient welding shall be provided on either side of the line through the center of the opening parallel to the longitudinal axis of the shell to develop the strength of the reinforcing parts as prescribed in [NE-3336](#), through shear or tension in the weld, whichever is applicable. The strength of groove welds shall be based on the area subjected to shear or to tension. The strength of fillet welds shall be based on the area subjected to shear computed on the minimum leg dimension. The inside diameter of a fillet weld shall be used in figuring its

Figure NE-3361-1
Category A and B Joints Between Sections of Unequal Thickness

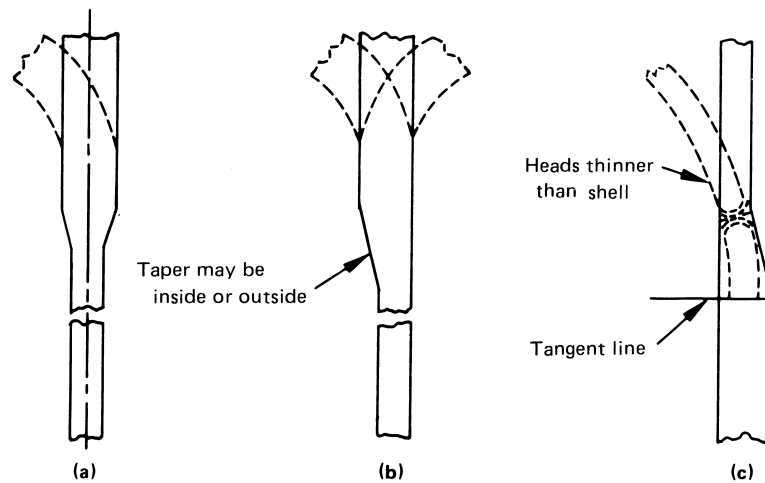

GENERAL NOTE: Length of taper may include the width of the weld.

length. Calculations are not required for full penetration welds.

(b) *Allowable Stress Values for Welds.* The allowable stress values for groove and fillet welds and for shear in nozzles, in percentage of stress values for the vessel material, are as follows:

- (1) nozzle wall shear, 70%
- (2) groove weld tension, 74%
- (3) groove weld shear, 60%
- (4) fillet weld shear, 49%

NE-3360 SPECIAL VESSEL REQUIREMENTS

NE-3361 Tapered Transitions

A tapered transition having a length not less than three times the offset between the adjacent surfaces of abutting sections (Figure NE-3361-1) shall be provided at joints between sections that differ in thickness by more than one-fourth the thickness of the thinner section or by more than $\frac{1}{8}$ in. (3 mm), whichever is less. The transition may be formed by any process that will provide a uniform taper. The weld may be partly or entirely in the tapered section or adjacent to it.

NE-3362 Bolted Flange and Studded Connections

(a) It is recommended that the dimensional requirements of bolted flange connections to external piping conform to ASME B16.5, Steel Pipe Flanges and Flanged Fittings; ASME B16.24, Cast Copper Alloy Pipe Flanges and Flanged Fittings; or to ASME B16.47, Large Diameter Steel Flanges. Such flanges and flanged fittings may be used for the pressure-temperature ratings given in the appropriate standard. Flanges and

flanged fittings in accordance with other standards are acceptable, provided they have been designed in accordance with the rules of Section III Appendices, Mandatory Appendix XI for the vessel Design Loadings and are used within the pressure-temperature ratings so determined.

(b) Where tapped holes are provided for studs, the threads shall be full and clean, and shall engage the stud for a length not less than the larger of d_s or:

$$0.75d_s \times \frac{\text{maximum allowable stress value of stud material at Design Temperature}}{\text{maximum allowable stress value of tapped material at Design Temperature}}$$

in which d_s is the diameter of the stud. The thread engagement need not exceed $1\frac{1}{2}d_s$.

NE-3363 Access Openings

Access openings, where provided, shall consist of hand-hole or manhole openings having removable covers. These may be located on either the inside or outside of the shell or head openings and may be attached by studs or bolts in combination with gaskets or welded membrane seals or strength welds. Plugs using pipe threads are not permitted.

NE-3364 Attachments

Attachments used to transmit support loads shall meet the requirements of NE-3135.

NE-3365 Supports

All vessels shall be so supported and the supporting members shall be so arranged and attached to the vessel wall as to provide for the maximum imposed loadings. The stresses produced in the vessel by such loadings and by steady state and transient thermal conditions shall be limited to the stress limits of this Subsection. For design of supports, see Subsection NF.

NE-3366 Bellows Expansion Joints

NE-3366.1 General Requirements.¹¹ Expansion or bellows-type joints may be used to provide flexibility for containment systems. Expansion joints in piping portions of the containment system shall meet the requirements for Class 2 piping. The expansion joints which are constructed as a part or appurtenance of the vessel shall conform to this Subsection and shall conform with the requirements of (a) through (h) below.

(a) Bellows may be used to absorb axial movement, lateral deflection, angular rotation, or any combination of these movements. They are not normally designed for absorbing torsion. The layout, anchorage, guiding, and support shall be such as to avoid the imposition of motions or forces on the bellows other than those for which they have been designed.

(b) In all systems containing bellows, the hydrostatic end force caused either by pressure or the bellows spring force or both must be resisted by rigid anchors, cross connections of the expansion joint ends, or other means.

(c) The expansion joint shall be installed in such locations as to be accessible for scheduled inspection, where applicable.

(d) The joints shall be provided with bars or other suitable members for maintaining the proper face-to-face dimension during shipment and installation. Bellows shall not be extended or compressed to make up deficiencies in length or offset to accommodate connecting parts which are not properly aligned unless such movements have been specified by the system designer or can be justified by the expansion joint manufacturer.

(e) The expansion joints shall be marked to show the direction of flow, if applicable, and shall be installed in accordance with this marking.

(f) Internal sleeves shall be provided for expansion joints over 6 in. (150 mm) in diameter when flow velocities exceed the following values:

(1) air, steam, and other gases — 25 ft/sec (7.6 m/s)

(2) water and other liquids — 10 ft/sec (3 m/s)

(g) Pressure-retaining materials shall conform to the requirements of Article NE-2000. Convolutions or toroids of a bellows expansion joint shall be fabricated from material in the annealed condition.

(h) All welded joints in the expansion joint shall comply with the requirements of NE-4400 and NE-4800.

NE-3366.2 Design Requirements. Bellows may be of the unreinforced or reinforced convoluted type or the toroidal type. The design shall conform to Article NE-3000 except as stipulated in (a) through (j) below.

(a) The circumferential membrane stresses in both the bellows and the reinforcing member, due to pressure, shall not exceed the allowable stress value for the material at the design temperature as defined in NE-3112.4(b).

(b) The sum of the bellows meridional membrane and bending stresses due to internal pressure shall not exceed a value which results in a permanent decrease in the measured space between adjacent convolutions of 7% after the pressure test required by NE-6230.

(c) The ratio of the internal pressure at which the bellows will become unstable (squirm) to the equivalent cold service pressure shall exceed 2.25. By definition, squirm shall be considered to have occurred if under internal pressure an initially symmetrical bellows deforms, resulting in a lack of parallelism or uneven spacing of adjacent convolutions at any point on the circumference. Unless otherwise specified, this deformation shall be construed as unacceptable squirm when the ratio of the maximum convolution pitch under internal pressure exceeds 1.15 for unreinforced and 1.20 for reinforced bellows. In the case of universal expansion joints, which consist of two bellows joined by a cylindrical section, compliance with these criteria shall be satisfied by the entire assembly. No external restraints on the bellows shall be employed during squirm testing other than those which will exist after installation.

(1) For single joints used in axial or lateral motion, the squirm test may be performed with the bellows fixed in the straight position at the maximum length expected in service; for rotation and universal joints, the bellows shall be held at the maximum design rotation angle or offset movement. In the case of single joints subjected to rotation movement, or of universal joints subjected to lateral offset movement, an instability condition as previously defined may or may not appear. Instead, movement of the convolutions may occur due to the superposition of the lateral internal pressure component on the applied rotation. In such cases, that portion of the bellows deformation due to the design rotation angle or offset movement shall not be included in the deformation used to define squirm.

(2) In the case of squirm tests, the equivalent cold service pressure is defined as the Design Pressure multiplied by the ratio E_c/E_h , where E_c and E_h are defined as the modulus of elasticity of the bellows material at room temperature and normal service temperature, respectively.

(d) The combination of meridional membrane and bending stresses S in the bellows due to internal pressure and deflection, multiplied by a stress factor K_s [see Section III Appendices, Mandatory Appendix II, II-1520(g)], shall not exceed the value defined by the following equation:

$$K_s \times S = S_f$$

where

$K_s = K_{sc} \times K_{ss}$, but never less than 1.25

K_{sc} = factor for differences in design fatigue curves at temperatures greater than 100°F (38°C), and is equal to:

$$\frac{2S_c}{S_c + S_h}$$

K_{ss} = factor for the statistical variation in test results = 1.470 – 0.044 times the number of replicate tests

S = total combined meridional membrane and bending stress, psi (MPa), due to pressure and deflection (the calculation of the individual stress components and their combination shall be determined by the same method as used for determining S_f); in the case of single joints subjected to rotation movement and universal joints subjected to lateral offset movement, the increase in deflection stress caused by the lateral internal pressure component shall be included in determining the combined stress, psi (MPa)

S_c = basic material allowable stress value at room temperature, psi (MPa), as defined in NE-3112.4(b)

S_f = total combined stress to failure at design cyclic life, psi (MPa), (number of cycles to failure) obtained from plots of stress versus cyclic life based on data from fatigue tests of a series of bellows at a given temperature (usually room temperature) evaluated by a best-fit continuous curve or series of curves; the S_f plot shall be parallel to the best-fit curve and shall lie below all of the data points

S_h = basic material allowable stress value at normal service temperature, psi (MPa), as defined in NE-3112.4(b)

(e) Compliance with (a), (b), (c), and (d) above shall be demonstrated by any one of the procedures of (1) through (3) below.

(1) Calculation of the individual stresses, whose combination and relation to fatigue life may be performed by any analytical method based on elastic shell theory. The resulting equations shall be substantiated by correlation with actual tests of a consistent series of bellows of the same basic design (unreinforced, reinforced, and toroidal bellows are considered as separate designs) by each bellows manufacturer in order to demonstrate predictability of rupture pressure, meridional yielding, squirm, and cyclic life. A minimum of five burst tests on bellows of varying sizes, with not less than three convolutions, shall be conducted to verify that the analytical

method will adequately satisfy (a) and (b) above. No specimen shall rupture at less than four times its equivalent cold pressure rating. A minimum of ten squirm tests on bellows of varying diameters and number of convolutions shall be conducted to verify that the analytical method will adequately satisfy (c) above. Since column instability is most likely to occur in bellows less than 20 in. (500 mm) in diameter when the convoluted bellows length is greater than its diameter, the test specimens shall reflect these considerations. In the case of universal expansion joints, two additional tests shall be conducted to verify that the analytical method will adequately satisfy (c) above. The cyclic life plot (versus the combined stress) used in evaluating (d) shall be obtained from the results of at least 25 fatigue tests on bellows of varying diameters, thicknesses, and convolution profiles. These curves may be used for diameter and convolution profiles other than those tested, provided that a variation in these dimensions has been included in the correlation with test data. Each group of five such tests on varying bellows may be considered the equivalent of one replicate test in determining K_s .

(2) Individual expansion joint designs may be shown to comply by the testing of duplicate bellows. At least two test specimens are required, one to demonstrate pressure capacity in accordance with (a), (b), and (c) above, and the second to demonstrate fatigue life in accordance with (d) above. In the case of rupture and fatigue tests, the specimens need not possess a duplicate number of convolutions provided that the number of convolutions is not less than three and the diameter, thickness, depth, and pitch of the specimen is identical to the part to be furnished. Squirm test specimens shall possess the total number of convolutions. The pressure test required by NE-6230 shall satisfy the instability test requirements for bellows larger than 50 in. (1300 mm) in diameter.

(-a) The test of (1) or (2) above may be conducted at room temperature provided that cold service pressure is defined as the Design Pressure multiplied by the ratio of S_c/S_h for rupture specimens and E_c/E_h for squirm specimens.

(-b) The fatigue life of the test specimen shall exceed $K_s^{4.3}$ times the number of design cycles specified for the most significant cyclic movements. This test shall include the effect of internal pressure. If lateral and rotation movements are specified, these may be converted to equivalent axial motion for cyclic testing; the convolution deflection produced by the lateral component of the internal pressure force during the squirm test (for single rotation joints and universal joints) shall be added to the mechanical deflections in determining fatigue life. Where accelerated fatigue testing is employed, the deflection and number of cycles required shall be in accordance with Section III Appendices, Mandatory Appendix II. Cumulative fatigue requirements can be satisfied in accordance with (g) without additional testing by

assuming that the slope of the fatigue curve is 4.3 (on a log-log plot) and that the curve passes through the test point.

(3) An individual design may be shown to comply by a design analysis in accordance with [NE-3200](#). The stresses at every point in the bellows shall be determined by either elastic shell theory or by a plastic analysis, where applicable. Where an elastic analysis is employed, stress intensity of Section II, Part D, Subpart 1, Tables 2A, 2B, and 4 and fatigue curves of Section III Appendices, Mandatory Appendix I may be used to evaluate the design. The stability requirements of (c) above may be demonstrated by either (-a) or (-b) below:

(-a) elastic stability calculations, provided that the ratio of the internal pressure at which the bellows is predicted to become unstable to the equivalent cold operating pressure exceeds 10; or

(-b) the pressure test of [NE-6230](#), provided that the test is conducted at 2.25 times the equivalent cold design pressure, and single rotation and universal joints are held at their design rotation angle or offset movement during the test and the requirements of (b) are not exceeded by such a test. [The pressure test required by [NE-6230](#) shall satisfy the instability test requirements for bellows larger than 50 in. (1300 mm) in diameter.]

(f) The bellows manufacturer's design report shall state which of the above procedures was utilized to verify the design.

(g) If there are two or more types of stress cycles which produce significant stresses, their cumulative effect shall be evaluated as stipulated in [NE-3221.5\(e\)\(5\)](#).

(h) Where necessary to carry the pressure, the cylindrical ends of the bellows may be reinforced by suitable collars; the design method used to assure that the stresses

generated will not cause premature failure of the bellows material or weldment shall include the attachment weld between the bellows and end connections.

(i) If reinforcing rings are used, they shall have the same radius as the root of the convolution.

(j) The Design Specifications shall state the maximum allowable force that can be imposed on the connecting parts or shall request the bellows manufacturer to determine the force necessary to deflect the bellows a given distance, preferably the maximum movement to be absorbed.

NE-3367 Closures on Small Penetrations

Closures on penetrations of NPS 2 (DN 50) or less may be made by the use of closure fittings such as blind flanges, welded plugs, or caps manufactured in accordance with standards listed in Table NCA-7100-1.

NE-3700 ELECTRICAL AND MECHANICAL PENETRATION ASSEMBLIES

NE-3720 DESIGN RULES

(a) The design of the pressure-retaining portion of the electrical and mechanical penetration assemblies shall be the same as for vessels ([NE-3300](#)).

(b) For closing seams in electrical and mechanical penetrations meeting the requirements of [NE-4730\(c\)](#), the closure head shall meet the requirements of [NE-3325](#) using a factor $C = 0.30$. The fillet weld shall be designed using an allowable stress of $0.5S_{mc}$.

ARTICLE NE-4000

FABRICATION AND INSTALLATION

NE-4100 GENERAL REQUIREMENTS

NE-4110 INTRODUCTION

Containment vessels, penetration assemblies, and appurtenances shall be fabricated and installed in accordance with the requirements of this Article, and shall be manufactured from materials which meet the requirements of [Article NE-2000](#).

NE-4120 CERTIFICATION OF MATERIAL AND FABRICATION BY COMPONENT CERTIFICATE HOLDER

NE-4121 Means of Certification

The Certificate Holder for an item for a containment vessel shall certify by application of the appropriate Certification Mark and completion of the appropriate Data Report in accordance with Article NCA-8000 that the materials used comply with the requirements of [Article NE-2000](#), and that the fabrication complies with the requirements of this Article.

NE-4121.1 Certification of Treatments, Tests, and Examinations. If the Certificate Holder or Subcontractor performs treatments, tests, repairs, or examinations required by other Articles of this Subsection, the Certificate Holder shall certify that this requirement has been fulfilled (NCA-3862 or NCA-8410). Reports of all required treatments and the results of all required tests, repairs, and examinations performed shall be available to the Inspector.

NE-4121.2 Repetition of Tensile or Impact Tests. If during the fabrication of the vessel the material is subjected to heat treatment that has not been covered by treatment of the test coupons ([NE-2200](#)) and that may reduce either the tensile or impact properties below the required values, the tensile and impact tests shall be repeated by the Certificate Holder on test specimens taken from test coupons which have been taken and treated in accordance with the requirements of [Article NE-2000](#).

NE-4122 Material Identification

(a) Material for pressure-retaining parts shall carry identification markings which will remain distinguishable until the component is assembled or installed. If the original identification markings are cut off or the material is divided, the marks shall be either transferred to the parts cut or a coded marking shall be used to assure identification of each piece of material during subsequent fabrication or installation. In either case, an as-built sketch or a tabulation of materials shall be made identifying each piece of material with the Certified Material Test Report, where applicable, and the coded marking. For studs, bolts, and nuts, it is permissible to identify the Certified Material Test Reports for material in each component in lieu of identifying each piece of material with the Certified Material Test Report and the coded marking. Material supplied with a Certificate of Compliance and welding materials shall be identified and controlled so that they can be traced to the vessel, or else a control procedure shall be employed which ensures that the specified material is used.

(b) Material from which the identification marking is lost shall be treated as nonconforming material until appropriate tests or other verifications are made and documented to assure material identification. Testing is required unless positive identification can be made by other documented evidence. The material may then be remarked, upon establishing positive identification.

NE-4122.1 Marking Material. Material shall be marked in accordance with [NE-2150](#).

NE-4123 Examinations

Visual examination activities that are not referenced for examination by other specific Code paragraphs, and are performed solely to verify compliance with requirements of [Article NE-4000](#), may be performed by the persons who perform or supervise the work. These visual examinations are not required to be performed by personnel and procedures qualified to [NE-5500](#) and [NE-5100](#), respectively, unless so specified.

NE-4125 Testing of Welding Material

All welding material shall meet the requirements of [NE-2400](#).

NE-4130 REPAIR OF MATERIAL

NE-4131 Elimination and Repair of Defects

Material originally accepted on delivery in which defects exceeding the limits of [NE-2500](#) are known or discovered during the process of fabrication or installation is unacceptable. The material may be used provided the condition is corrected in accordance with the requirements of [NE-2500](#) for the applicable product form, except:

(a) the limitation on the depth of the weld repair does not apply;

(b) the time of examination of the weld repairs to weld edge preparations shall be in accordance with [NE-5130](#); and

(c) radiographic examination is not required for weld repairs to seal membrane material when the material thickness is $\frac{1}{4}$ in. (6 mm) or less.

NE-4200 FORMING, FITTING, AND ALIGNING

NE-4210 CUTTING, FORMING, AND BENDING

(21) NE-4211 Cutting

Materials may be cut to shape and size by mechanical means, such as machining, shearing, chipping, or grinding, or by thermal cutting.

NE-4211.1 Preheating Before Thermal Cutting. When thermal cutting is performed to prepare weld joints or edges, to remove attachments or defective material, or for any other purpose, consideration shall be given to preheating the material using preheat schedules such as suggested in Section III Appendices, Nonmandatory Appendix D.

NE-4212 Forming and Bending Processes

Any process may be used to hot or cold form or bend pressure-retaining material, including weld metal, provided the required dimensions are attained (see [NE-4214](#) and [NE-4220](#)), and provided the impact properties of the material, when required, are not reduced below the minimum specified values or they are effectively restored by heat treatment following the forming operation. *Hot forming* is defined as forming with the material temperature higher than 100°F (56°C) below the lower transformation temperature of the material. When required, the process shall be qualified for impact properties as outlined in [NE-4213](#).

NE-4212.1 Required Postweld Heat Treatment. Vessel shell sections and heads of P-No.1 material fabricated by cold forming shall be postweld heat treated when the resulting maximum extreme fiber elongation is more than 5%.

NE-4213 Qualification of Forming Processes for Impact Property Requirements

A procedure qualification test shall be conducted using specimens taken from material of the same specification, grade or class, heat treatment, and with similar impact properties as required for the material in the vessel. These specimens shall be subjected to the equivalent forming or bending process and heat treatment as the material in the vessel. Applicable tests shall be conducted to determine that the required impact properties of [NE-2300](#) are met after straining.

NE-4213.1 Exemptions. Procedure qualification tests are not required for material listed in (a) through (f) below:

(a) hot formed material, such as forgings, in which the hot forming is completed by the Material Organization prior to removal of the impact test specimens;

(b) hot formed material represented by test coupons required in either [NE-2211](#) or [NE-4121.2](#) which have been subjected to heat treatment representing the hot forming procedure and the heat treatments to be applied to the parts;

(c) material which does not require impact tests in accordance with [NE-2300](#);

(d) material which has final strain less than 0.5%;

(e) material where the final strain is less than that of a previously qualified procedure for that material;

(f) material from which the impact testing required by [NE-2300](#) is performed on each heat and lot, as applicable, after forming.

NE-4213.2 Procedure Qualification Test. The procedure qualification test shall be performed in the manner stipulated in (a) through (f) below.

(a) The tests shall be performed on three different heats of material both before and after straining to establish the effects of the forming and subsequent heat treatment operations.

(b) Specimens shall be taken in accordance with the requirements of [Article NE-2000](#) and shall be taken from the tension side of the strained material.

(c) The percent strain shall be established by the following equations.

For cylinders:

$$\% \text{ strain} = \frac{50t}{R_f} \left(1 - \frac{R_f}{R_o} \right)$$

For spherical or dished surfaces:

$$\% \text{ strain} = \frac{75t}{R_f} \left(1 - \frac{R_f}{R_o} \right)$$

For pipe:

$$\% \text{ strain} = \frac{100r}{R}$$

where

R = nominal bending radius to the center line of the pipe

r = nominal radius of the pipe

R_f = final radius to center line of shell

R_o = original radius (equal to infinity for a flat part)

t = nominal thickness

(d) The procedure qualification shall simulate the maximum percent surface strain, employing a bending process similar to that used in the fabrication of the material or by direct tension on the specimen.

(e) Sufficient C_v test specimens shall be taken from each of the three heats of material to establish a transition curve showing both the upper and lower shelves. On each of the three heats, tests consisting of three impact specimens shall be conducted at a minimum of five different temperatures distributed throughout the transition region. The upper and lower shelves may be established by the use of one test specimen for each shelf. Depending on the product form, it may be necessary to plot the transition curves using both lateral expansion and energy level data (NE-2300). In addition, drop weight tests shall be made when required by NE-2300.

(f) Using the results of the impact test data from each of three heats taken both before and after straining, determine either:

(1) the maximum change in NDT temperature along with:

(-a) the maximum change of lateral expansion and energy at the temperature under consideration; or

(-b) the maximum change of temperature at the lateral expansion and energy levels under consideration; or

(2) when lateral expansion is the acceptance criterion (NE-2300), either the maximum change in temperature or the maximum change in lateral expansion.

NE-4213.3 Acceptance Criteria for Formed Material.

To be acceptable, the formed material used in the vessel shall have impact properties before forming sufficient to compensate for the maximum loss of impact properties due to the qualified forming procedure used.

NE-4213.4 Requalification. A new procedure qualification test is required when any of the following changes are made:

(a) the actual postweld heat treatment time at temperature is greater than previously qualified, considering NE-2211:

(1) if the material is not postweld heat treated, the procedure shall be qualified without postweld heat treatment;

(b) the maximum calculated strain of the material exceeds the previously qualified strain by more than 0.5%;

(c) where preheat over 250°F (120°C) is used in the forming or bending operation but not followed by a subsequent postweld heat treatment.

NE-4214 Minimum Thickness of Fabricated Material

If any fabrication operation reduces the thickness below the minimum required to satisfy the rules of Article NE-3000, the material may be repaired in accordance with NE-4130.

NE-4220 FORMING TOLERANCES

NE-4221 Tolerance for Vessel Shells

Cylindrical, conical, or spherical shells of a completed vessel, except for formed heads covered by NE-4222, shall meet the requirements of the following subparagraphs at all cross sections. If the plates are to be rolled, the adjoining edges of longitudinal joints of cylindrical vessels shall first be shaped to the proper curvature by preliminary rolling or forming in order to avoid having objectional flat spots along the completed joints.

NE-4221.1 Maximum Difference in Cross-Sectional Diameters. The difference between the maximum and minimum inside diameters at any cross section shall not exceed 1% of the nominal diameter at the cross section under consideration. The diameters may be measured on the inside or outside of the vessel. If measured on the outside, the diameters shall be corrected for the plate thickness at the cross section under consideration (Figure NE-4221.1-1). When the cross section passes through an opening, the permissible difference in inside diameters given above may be increased by 2% of the inside diameter of the opening.

NE-4221.2 Maximum Deviation From True Theoretical Form for External Pressure. Vessels designed for external pressure shall meet the following tolerances.

(a) The maximum plus-or-minus deviation from the true circular form of cylinders or the theoretical form of other shapes, measured radially on the outside or inside of the component, shall not exceed the

Figure NE-4221.1-1
Maximum Difference in Cross-Sectional Diameters

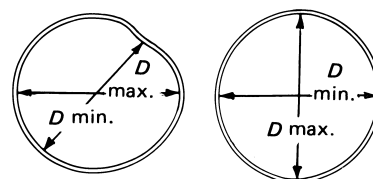
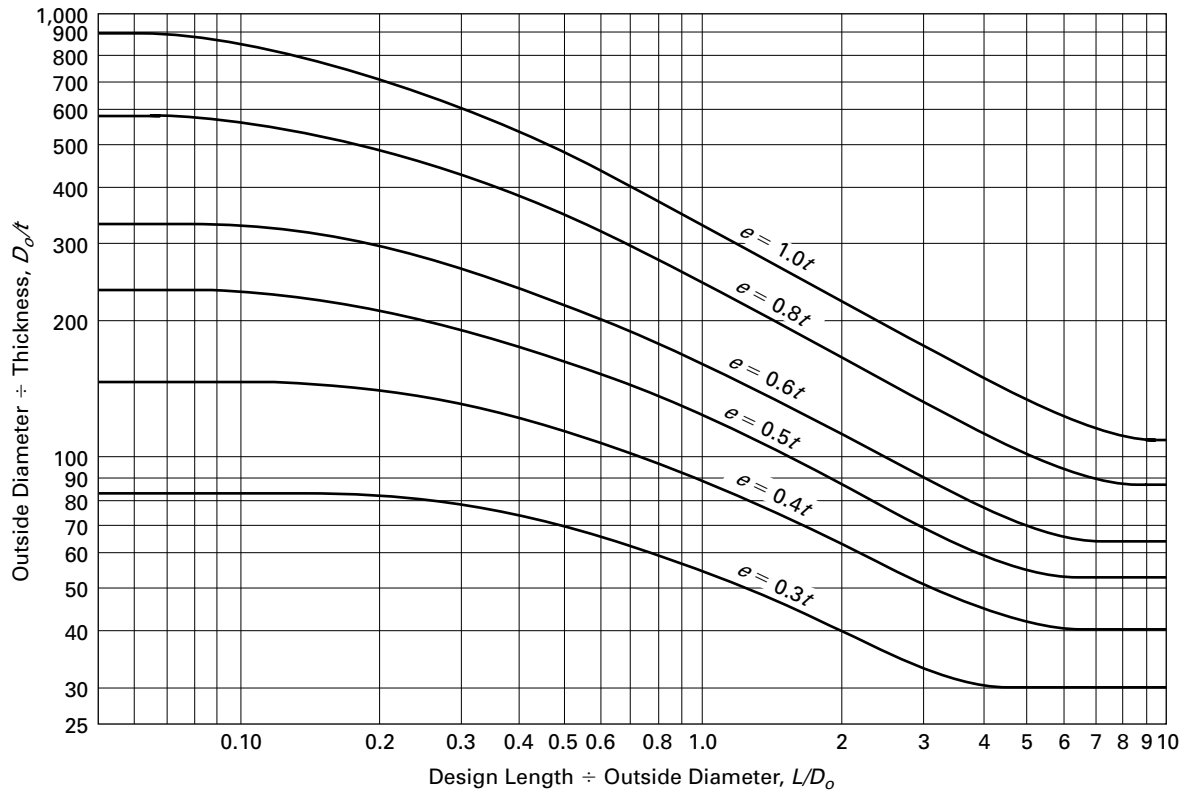

Figure NE-4221.2-1
Maximum Permissible Deviation e From a True Circular Form



maximum permissible deviation obtained from [Figure NE-4221.2-1](#). Measurements shall be made from a segmental circular template having the design inside or outside radius (depending on where the measurements are taken) and a chord length equal to twice the arc length obtained from [Figure NE-4221.2-2](#). For [Figure NE-4221.2-1](#), the maximum permissible deviation e need not be less than $0.3t$. For [Figure NE-4221.2-2](#), the arc length need not be greater than $0.30D_o$. Measurements shall not be taken on welds or other raised parts.

(b) The value of t in in. (mm) at any cross section is the nominal plate thickness less corrosion allowance for sections of constant thickness and the nominal thickness of the thinnest plate less corrosion allowance for sections having plates of more than one thickness.

(c) The value of L in [Figures NE-4221.2-1](#) and [NE-4221.2-2](#) is determined as follows:

(1) For cylinders, L is as given in [NE-3133.2](#).

(2) For cones, L is the axial length of the conical section if no stiffener rings are used or, if stiffener rings are used, the axial length from the head bend line at the large end of the cone to the first stiffener ring, with D_o taken as the outside diameter in inches of the cylinder at the large end of the cone.

(3) For spheres, L is one-half of the outside diameter D_o , in. (mm).

NE-4221.3 Deviations From Tolerances. Deviations from the tolerance requirements stipulated in [NE-4221.1](#) and [NE-4221.2](#) are permitted, provided the drawings are modified and reconciled with the Design Report and provided the modifications are certified by a Certifying Engineer in an addendum to the Design Report.

NE-4221.4 Tolerance Deviations for Vessel Parts Fabricated From Pipe. Vessel parts subjected to either internal or external pressure and fabricated from pipe, meeting all other requirements of this Subsection, may have variations of diameter and deviations from circularity permitted by the specification for such pipe.

NE-4221.5 Localized Thin Areas. Localized thin areas are permitted if the adjacent areas surrounding each has sufficient thickness to provide the necessary reinforcement according to the rules for reinforcement in [NE-3330](#).

NE-4222 Tolerances for Formed Vessel Heads

The tolerance for formed vessel heads shall be as set forth in the following subparagraphs.

Figure NE-4221.2-2
Maximum Arc Length for Determining Plus or Minus Deviation

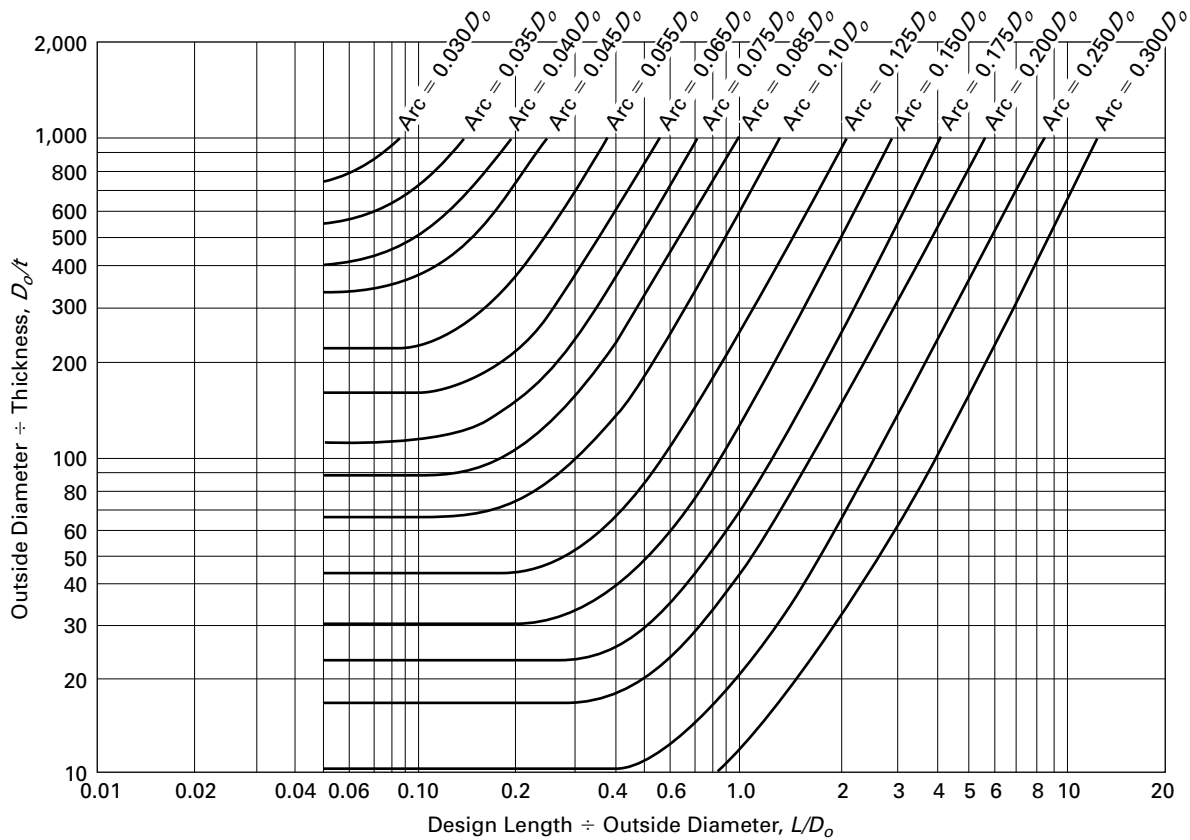

NE-4222.1 Maximum Difference in Cross-Sectional Diameters. The skirt or cylindrical end of a formed head shall be circular to the extent that the difference in inches (mm) between the maximum and minimum diameters does not exceed the lesser of

(U.S. Customary Units)

$$\frac{D + 50}{200} \quad \text{and} \quad \frac{D + 12}{100}$$

(SI Units)

$$\frac{D + 1\,250}{200} \quad \text{and} \quad \frac{D + 300}{100}$$

where D is the nominal inside diameter, in. (mm), and shall match the cylindrical edge of the adjoining part within the alignment tolerance specified in [NE-4232](#).

NE-4222.2 Deviation From Specified Shape.

(a) The inner surface of a torispherical or ellipsoidal head shall not deviate outside the specified shape by more than $1\frac{1}{4}\%$ of D , or inside the specified shape by more than $\frac{5}{8}\%$ of D , where D is the nominal inside diameter of the vessel. Such deviations shall be measured perpendicular to the specified shape and shall not be abrupt. The knuckle radius shall not be less than specified. For 2:1 ellipsoidal heads, the knuckle radius may be considered to be 17% of the diameter of the vessel.

(b) Hemispherical heads and any spherical portion of a formed head shall meet the local tolerances for spheres as given in [NE-4221.2](#), using L as the outside spherical radius in inches and D_o as two times L .

(c) Deviation measurements shall be taken on the surface of the base material and not on welds.

Table NE-4232-1
Maximum Allowable Offset in Final Welded Joints

Section Thickness, in. (mm)	Longitudinal, in. (mm)	Circumferential, in. (mm)
Up to $\frac{1}{2}$ (13), incl.	$\frac{1}{4}t$	$\frac{1}{4}t$
Over $\frac{1}{2}$ to $\frac{3}{4}$ (13 to 19), incl.	$\frac{1}{8}$ (3)	$\frac{1}{4}t$
Over $\frac{3}{4}$ to $1\frac{1}{2}$ (19 to 38), incl.	$\frac{1}{8}$ (3)	$\frac{3}{16}$ (5)
Over $1\frac{1}{2}$ to 2 (38 to 50), incl.	$\frac{1}{8}$ (3)	$\frac{1}{8}t$
Over 2 (50)	Lesser of $\frac{1}{16}t$ and $\frac{3}{8}$ (10)	Lesser of $\frac{1}{8}t$ and $\frac{3}{4}$ (19)

NE-4230 FITTING AND ALIGNING

NE-4231 Fitting and Aligning Methods

Parts that are to be joined by welding may be fitted, aligned, and retained in position during the welding operation by the use of bars, jacks, clamps, tack welds, or temporary attachments.

NE-4231.1 Tack Welds. Tack welds used to secure alignment shall be either removed completely, when they have served their purpose, or their stopping and starting ends shall be properly prepared by grinding or other suitable means so that they may be satisfactorily incorporated into the final weld. Tack welds shall be made by qualified welders using qualified welding procedures. When tack welds are to become part of the finished weld, they shall be visually examined and defective tack welds removed.

NE-4232 Maximum Offset of Aligned Sections

(a) Alignment of sections shall be such that the maximum offset of the finished weld will not be greater than the applicable amount listed in [Table NE-4232-1](#), where t is the nominal thickness of the thinner section at the joint.

(b) Joints in spherical vessels, joints within heads, and joints between cylindrical shells and hemispherical heads shall meet the requirements in [Table NE-4232-1](#) for longitudinal joints.

NE-4232.1 Fairing of Offsets. Any offset within the allowable tolerance provided above shall be faired to at least a 3:1 taper over the width of the finished weld, or, if necessary, by adding additional weld metal beyond what would otherwise be the edge of the weld. In addition, offsets greater than those stated in [Table NE-4232-1](#) are acceptable provided the requirements of [NE-3200](#) are met.

NE-4240 REQUIREMENTS FOR WELD JOINTS

NE-4241 Category A Weld Joints

Category A weld joints shall be full penetration butt-welded joints. Joints that have been welded from one side with backing that has been removed, and those welded from one side without backing, are acceptable as full penetration welds provided the weld root side of the joints meet the requirements of [NE-4424](#).

NE-4242 Category B Weld Joints

Category B weld joints shall be full penetration butt-welded joints, except that NPS 2 (DN 50) and smaller pipe sizes may be socket welded. Joints made with consumable inserts or gas backup, or with metal backing rings or strips which are later removed, are acceptable as full penetration joints. When used, backing strips shall be continuous in cross section. Joints prepared with opposing lips to form an integral backing strip and joints with backing strips which are not later removed are acceptable.

NE-4243 Category C Weld Joints

Category C weld joints shall be full penetration joints, as shown in [Figures NE-4243-1](#) and [NE-4243-2](#), except that socket welded flanges of NPS 2 (DN 50) and less and slip-on flanges may be used.

NE-4243.1 Flat Heads and Tubesheets With Hubs. Hubs for butt welding to the adjacent shell, head, or other pressure part, as in [Figure NE-4243.1-1](#), shall not be machined from rolled plate. The component having the hub shall be forged in such a manner as to provide in the hub the full minimum tensile strength and elongation specified for the material, in a direction parallel to the axis of the vessel. Proof of this shall be furnished by a tension test specimen, subsize if necessary, taken in this direction and as close to the hub as is practical.¹² In no case shall the height of the hub be less than 1.5 times the thickness of the pressure part to which it is welded.

NE-4244 Category D Weld Joints

Category D and similar weld joints shall be welded using one of the details of (a) through (g) below.

(a) *Butt-Welded Nozzles.* Nozzles shall be attached by full penetration butt welds through either the vessel or the nozzle wall, as shown in [Figure NE-4244\(a\)-1](#). Backing strips, if used, may be left in place.

(b) *Full Penetration Corner-Welded Nozzles.* Nozzles shall be attached by full penetration welds through the wall of the vessel or nozzle similar to those shown in [Figure NE-4244\(b\)-1](#). When complete joint penetration cannot be verified by visual examination or other

Figure NE-4243-1
Attachment of Pressure Parts to Plates to Form a Corner Joint

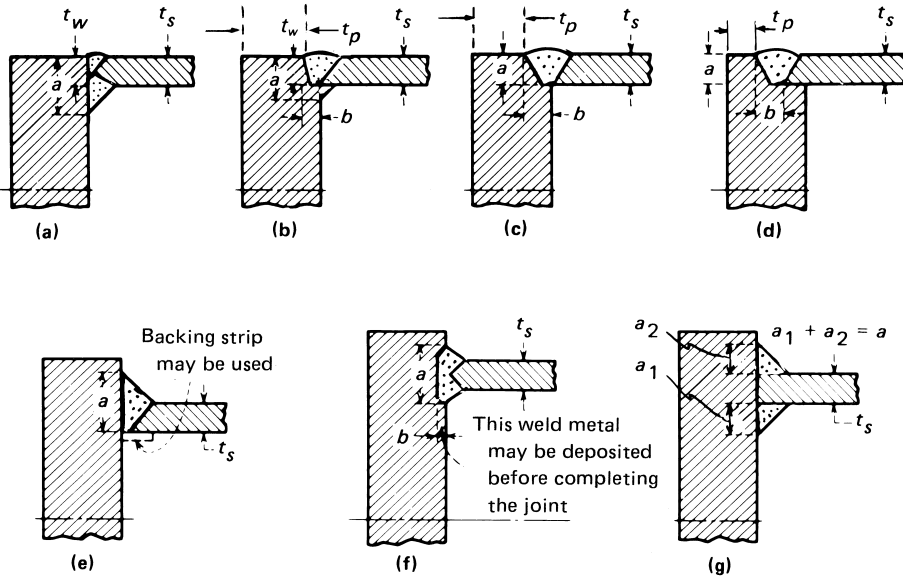

Typical Unstayed Flat Heads and Side Plates of Rectangular Vessels
[Notes (1) and (2)]

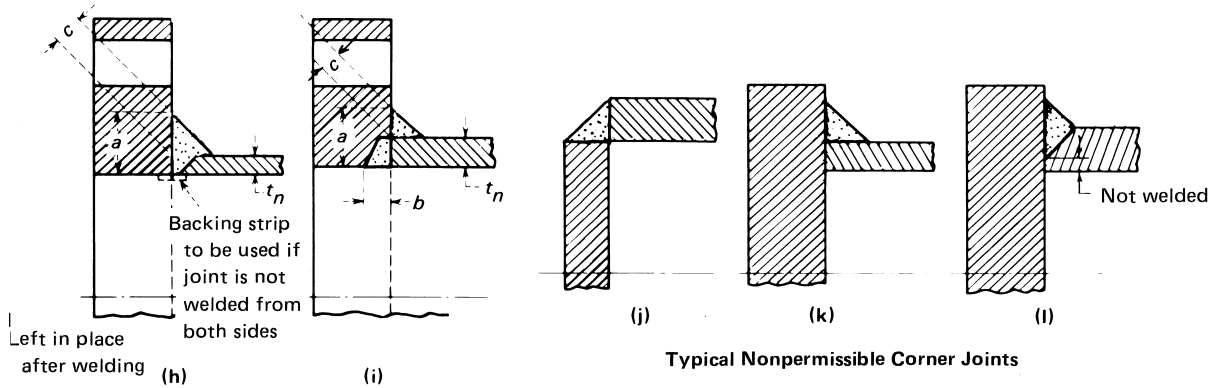

Typical Bolted Flange Connections
[Notes (2) and (3)]

NOTES:

- (1) For unstayed flat heads, see [NE-3325](#); t_s , t_p , and t_w are as defined in [NE-3325.1](#).
- (2) For definitions of a and b , see [NE-3358.3](#).
- (3) c and t_n are as defined in Section III Appendices, Mandatory Appendix XI, XI-3130.

Figure NE-4243-2
Acceptable Types of Full Penetration Weld Details for Category C Joints

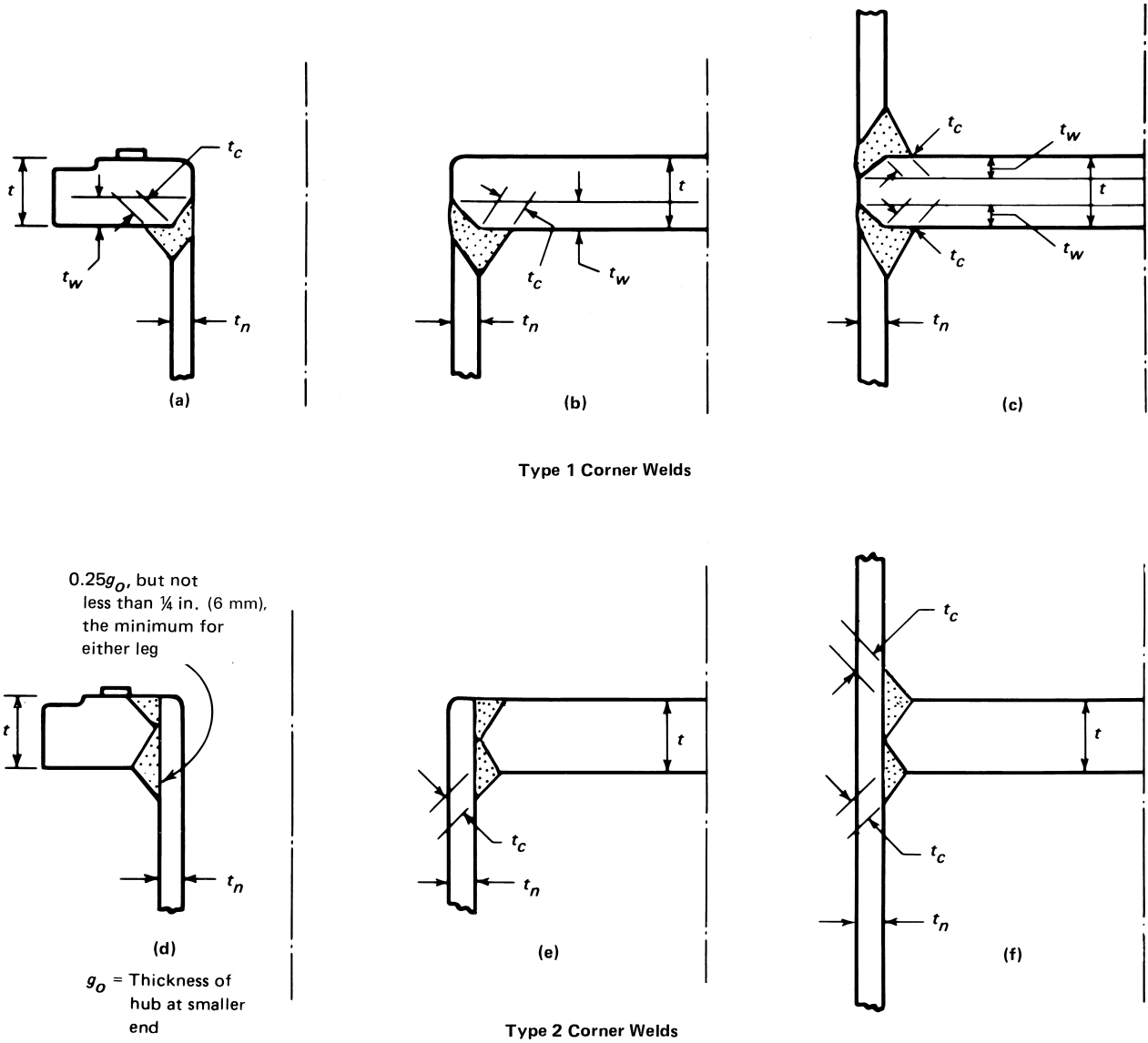

GENERAL NOTE: t and t_n are nominal thickness.

**Figure NE-4243.1-1
Typical Flat Heads**

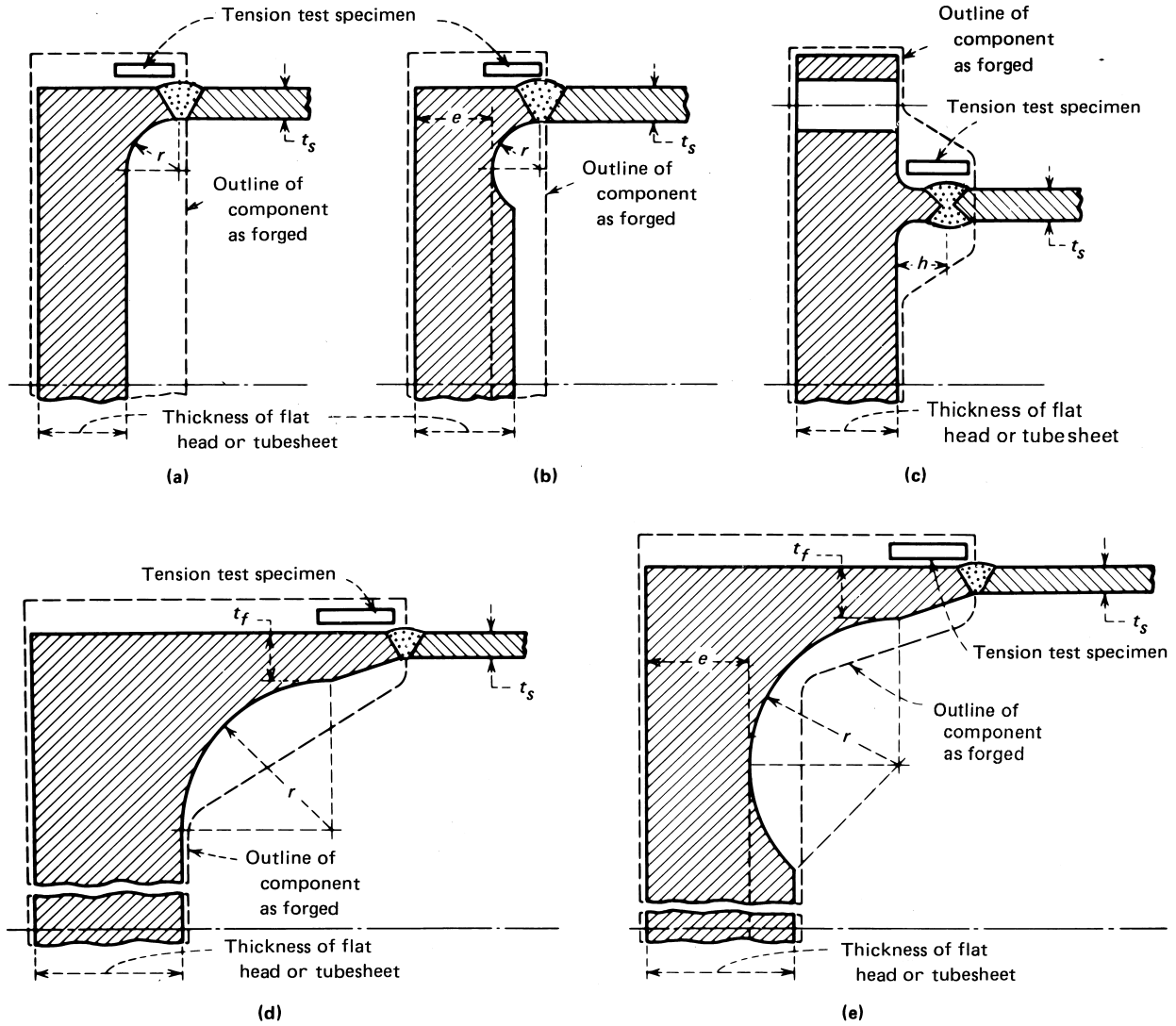

GENERAL NOTE: Not permissible if machined from rolled plate. The tension test specimen may be located, when possible, inside the forged hub, instead of outside, as shown.

Figure NE-4244(a)-1
Nozzles Attached by Full Penetration Butt Welds

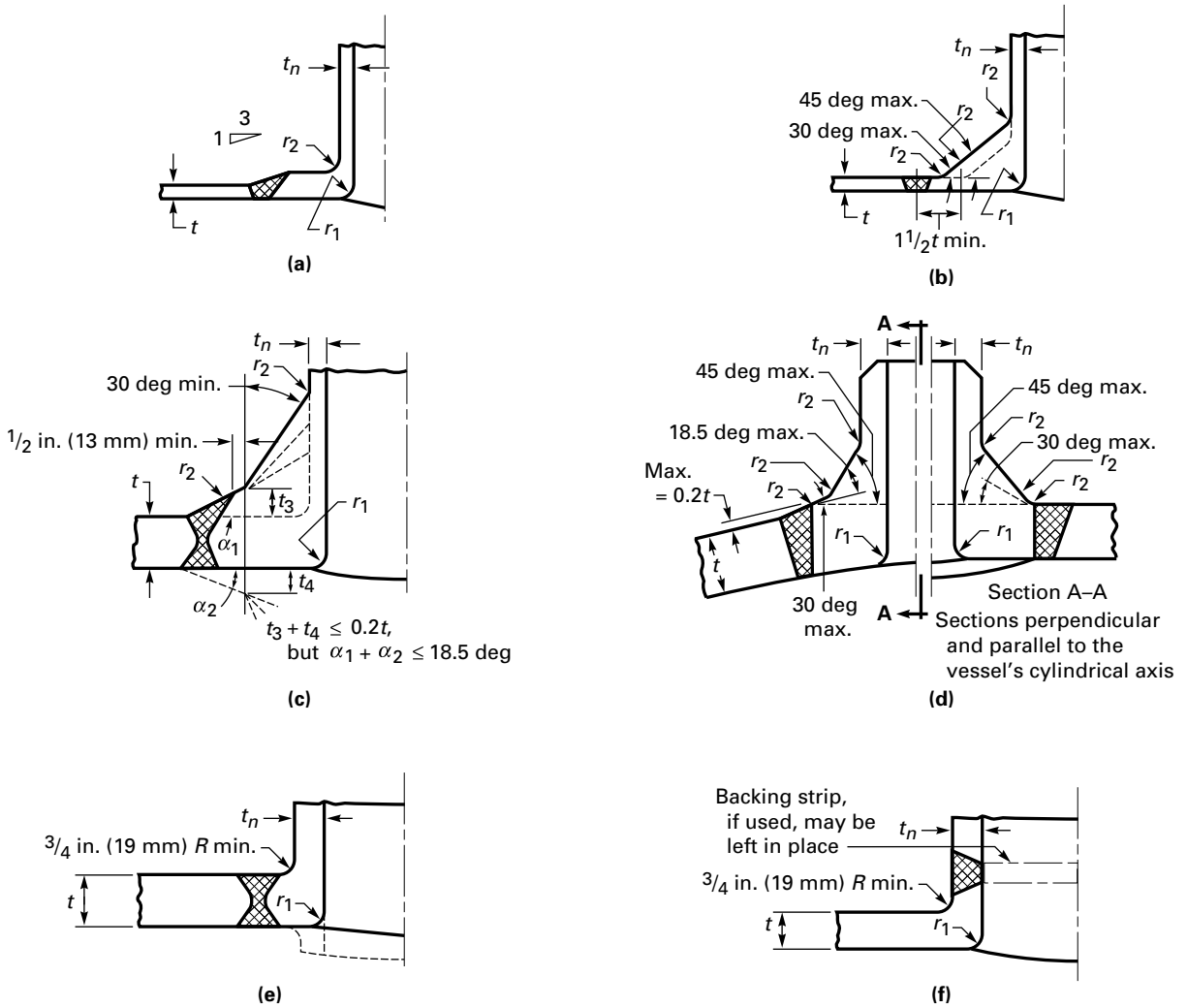

GENERAL NOTE: For definition of symbols, see [NE-3352.4\(a\)](#).

Figure NE-4244(b)-1
Nozzles Attached by Full Penetration Corner Welds

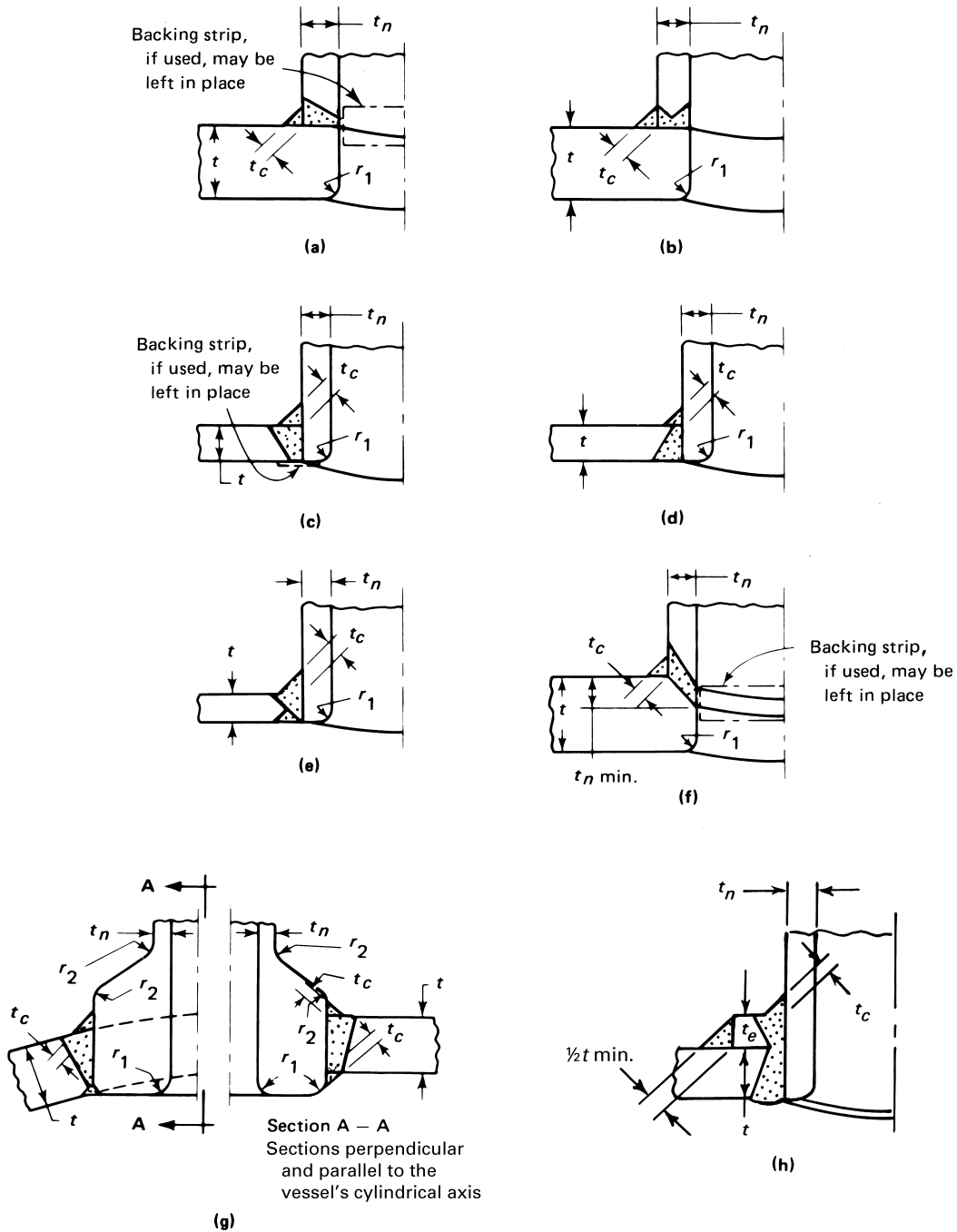

GENERAL NOTE: For definition of symbols, see [NE-3352.4\(b\)](#).

means permitted, backing strips or equivalent shall be used with full penetration welds deposited from only one side. Backing strips, if used, may be left in place.

(c) *Use of Deposited Weld Metal for Opening and Nozzles.* Nozzles shall be joined to the vessel by full penetration weld to built-up weld deposits which may be applied to either the vessel or nozzle wall as shown in Figure NE-4244(c)-1. Backing strips, if used, may be left in place. Fillet welds shall be used in the attachment of nozzles only to provide a transition between the parts joined or to provide a seal. The fillet welds, when used, shall be finished by grinding to provide a smooth surface having a transition radius at its intersection with either part being joined.

(d) *Attachment of Nozzles Using Partial Penetration Welds.* Partial penetration welds shall meet the requirements of NE-3352.4(d) and NE-3359. Nozzles shall be attached as shown in Figure NE-4244(d)-1, Figure NE-4244(d)-2, or Figure NE-4244(d)-3.

(e) *Attachment of Fittings With Internal Threads.* Internally threaded fittings shall be attached by a full penetration groove weld, or for NPS 2 (DN 50) and less by two fillet or partial penetration welds, one on each face of the vessel wall, or by a fillet groove weld from the outside only as shown in Figure NE-4244(e)-1, sketch (c-3). Internally threaded fitting and bolting pads not exceeding NPS 3 (DN 80), as shown in Figure NE-4244(e)-2, may be attached to vessels having a wall thickness not greater than $\frac{3}{8}$ in. (10 mm) by a fillet weld, deposited from the outside only. The design requirements of NE-3352.4(e) shall be met for all vessels.

(f) *Tubed Connections.* Nozzles or tubes recessed into thick walled components or parts may be welded from only one side provided the requirements of NE-3352.4(f) are met. Typical connections are shown in Figure NE-4244(f)-1.

(g) *Reinforcing Plates.* Reinforcing plates of nozzles attached to the outside of a vessel shall be provided with at least one telltale hole [maximum size $\frac{1}{4}$ in. (6 mm) pipe tap] that may be tapped for a preliminary compressed air and soapsuds test for tightness of welds. These telltale holes may be left open or may be plugged when the vessel is in service. If the holes are plugged, the plugging material used shall not be capable of sustaining pressure between the reinforcing plate and the vessel wall.

NE-4300 WELDING QUALIFICATIONS

NE-4310 GENERAL REQUIREMENTS

NE-4311 Types of Processes Permitted

Only those welding processes which are capable of producing welds in accordance with the welding procedure qualification requirements of Section IX and this

Subsection may be used for welding pressure-retaining material or attachments thereto. Any process used shall be such that the records required by NE-4320 can be prepared, except that records for stud welds shall be traceable to the welders and welding operators and not necessarily to each specific weld.

NE-4311.1 Stud Welding Restrictions. Stud welding is acceptable only for nonstructural and temporary attachments (NE-4435). Studs shall be limited to 1 in. (25 mm) maximum diameter for round studs and an equivalent cross-sectional area for studs of other shapes when welding in the flat position and $\frac{3}{4}$ in. (19 mm) diameter for all other welding positions. Postweld heat treatment shall comply with NE-4600, except that time at temperature need not exceed $\frac{1}{2}$ hr, regardless of base material thickness. Welding procedure and performance qualification shall comply with the requirements of Section IX.

NE-4311.2 Capacitor Discharge Welding. Capacitor discharge welding may be used for welding temporary attachments and permanent nonstructural attachments provided:

(a) temporary attachments are removed in accordance with the provisions of NE-4435(b); and

(b) the energy output for permanent nonstructural attachments such as strain gages and thermocouples is limited to 125 W-sec and the minimum thickness of the material to which the attachment is made is greater than 0.09 in. (2.3 mm); and

(c) a Welding Procedure Specification is prepared describing the capacitor discharge equipment, the combination of materials to be joined, and the technique of application; qualification of the welding procedure is not required.

NE-4311.4 Inertia and Continuous Drive Friction Welding. Inertia and continuous drive friction welding shall not be used in the fabrication of containment vessels.

NE-4320 WELDING QUALIFICATIONS, RECORDS, AND IDENTIFYING STAMPS

NE-4321 Required Qualifications

(a) Each Certificate Holder is responsible for the welding done by his organization, and he shall establish the procedure and conduct the tests required by this Article and by Section IX in order to qualify both the welding procedures and the performance of welders and welding operators who apply these procedures.

(b) Procedures, welders, and welding operators used to join permanent or temporary attachments to pressure parts and to make permanent or temporary tack welds used in such welding shall also meet the qualification requirements of this Article.

Figure NE-4244(c)-1
Deposited Weld Metal for Openings and Nozzles

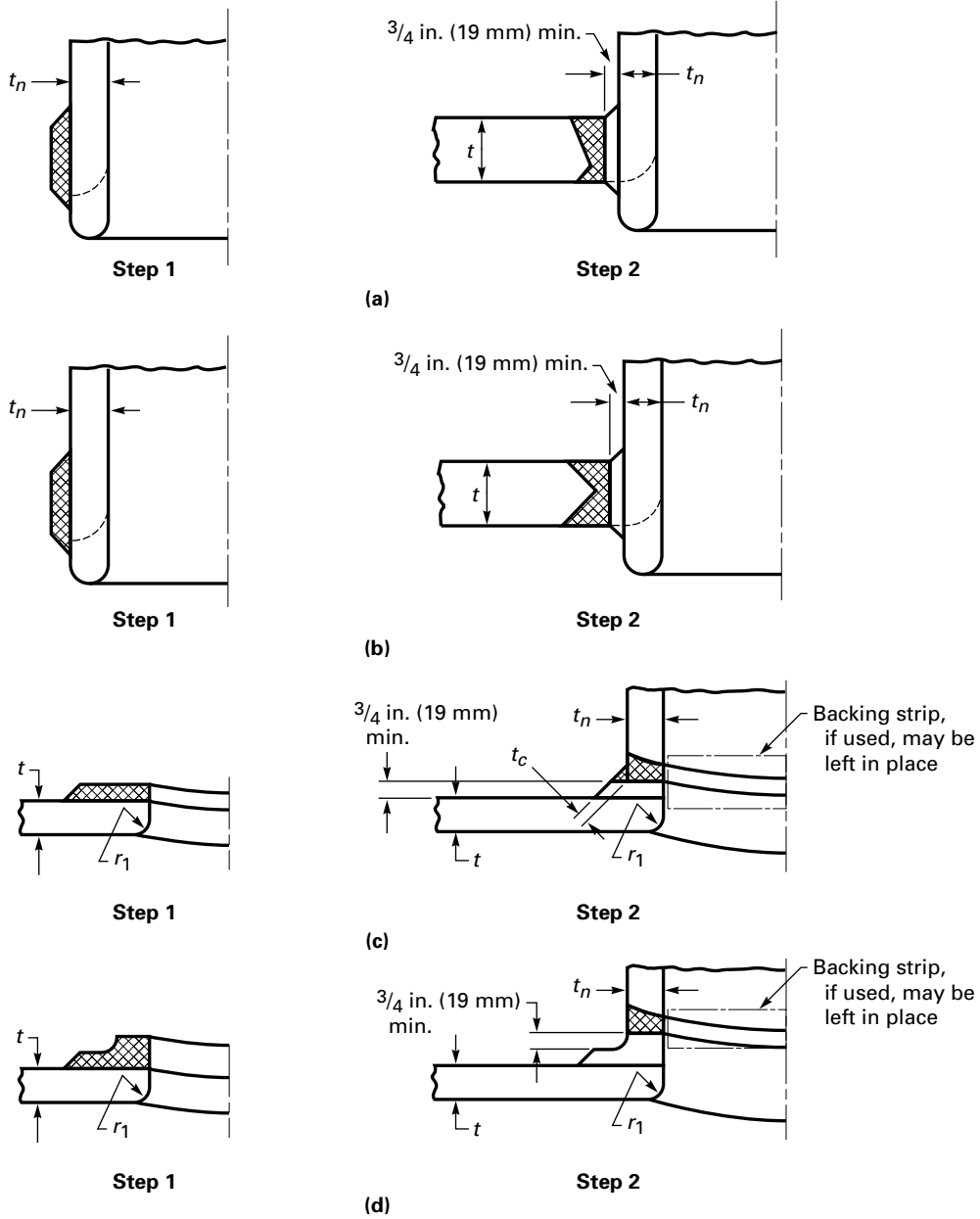

GENERAL NOTE: For definition of symbols, see [NE-3352.4\(c\)](#).

Figure NE-4244(d)-1
Acceptable Types of Welded Nozzles Using Partial Penetration Welds

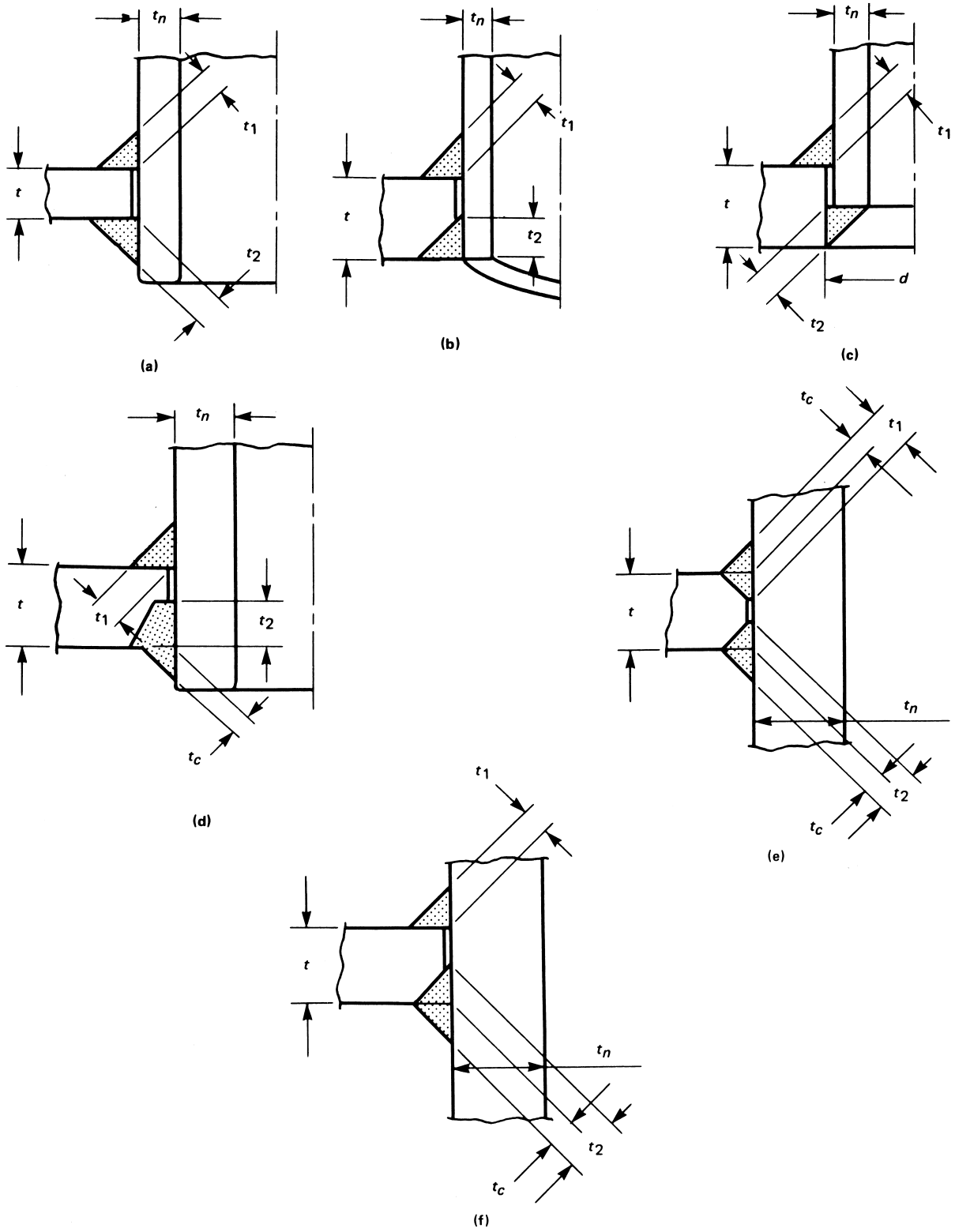

GENERAL NOTE: For definition of symbols, see [NE-3352.4\(d\)](#).

Figure NE-4244(d)-2
Partial Penetration Weld Connections

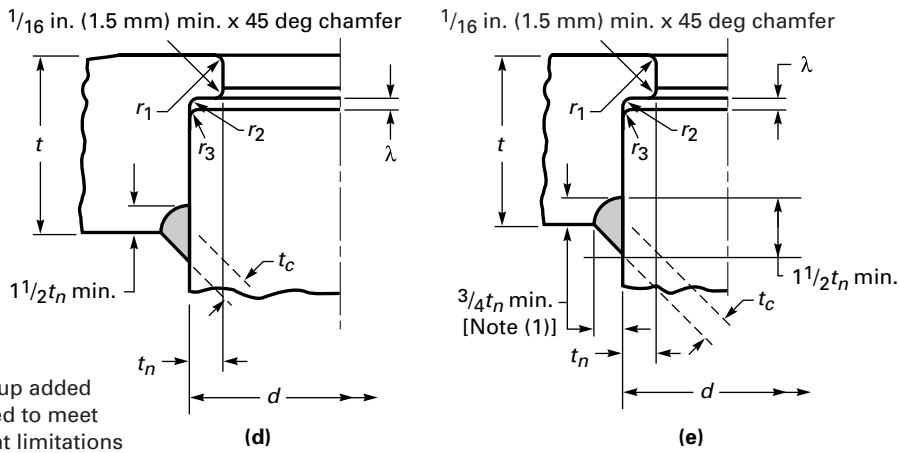
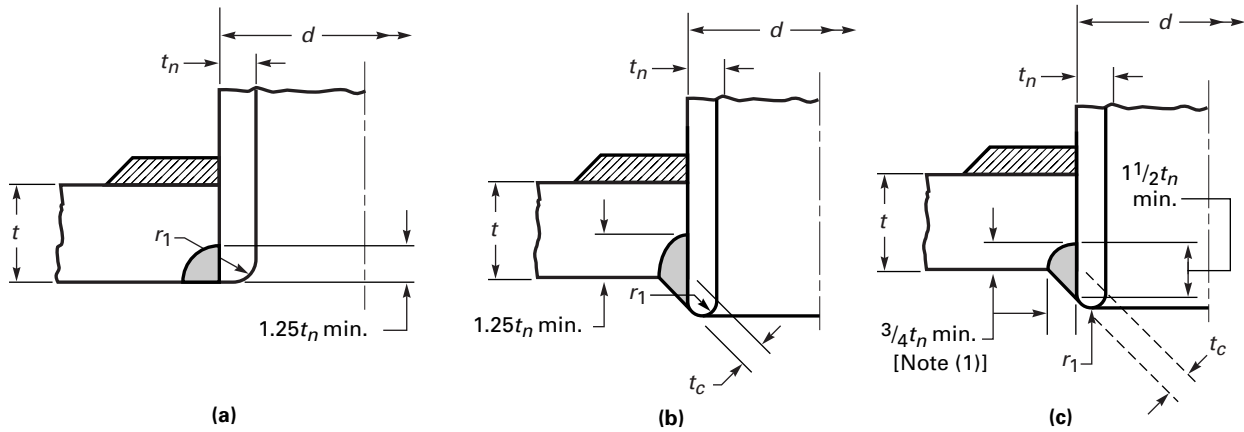

 Welding buildup added when required to meet reinforcement limitations [Notes (2) and (3)]

GENERAL NOTE: For definition of symbols, see [NE-3352.4\(d\)](#).

NOTES:

- (1) The $\frac{3}{4}t_n$ minimum dimension applies to the fillet leg and groove depth.
- (2) Weld deposit, if used, shall be examined as required by [NE-5244](#).
- (3) Weld buildups are not attached to the nozzle.

Figure NE-4244(d)-3
Partial Penetration Weld Connections for Coaxial Cylinders

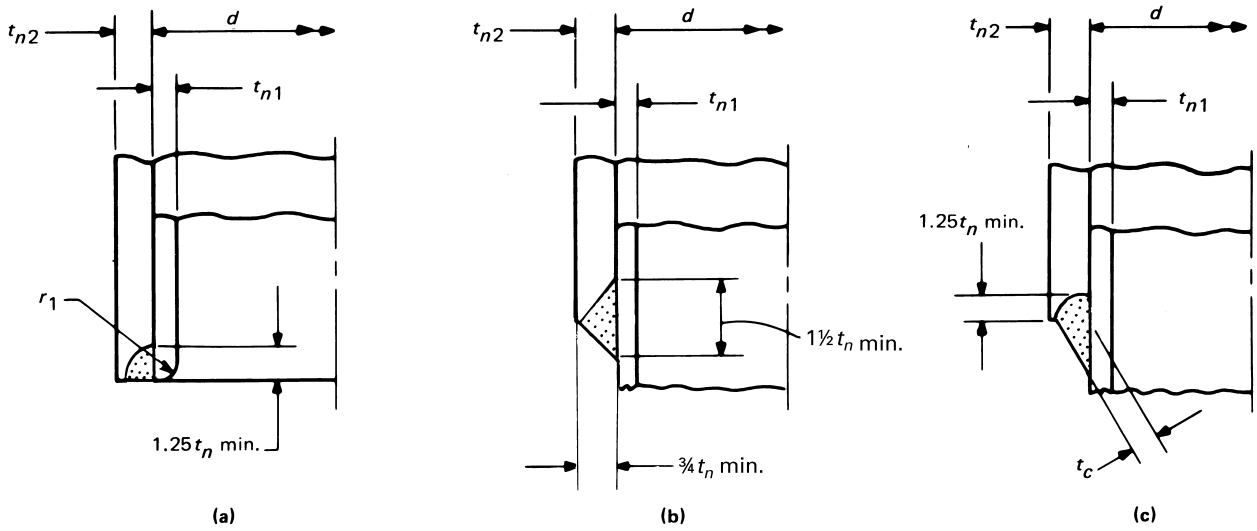

GENERAL NOTE: For definition of symbols, see NE-3352.4(d).

Figure NE-4244(e)-1
Acceptable Types of Fittings With Internal Threads

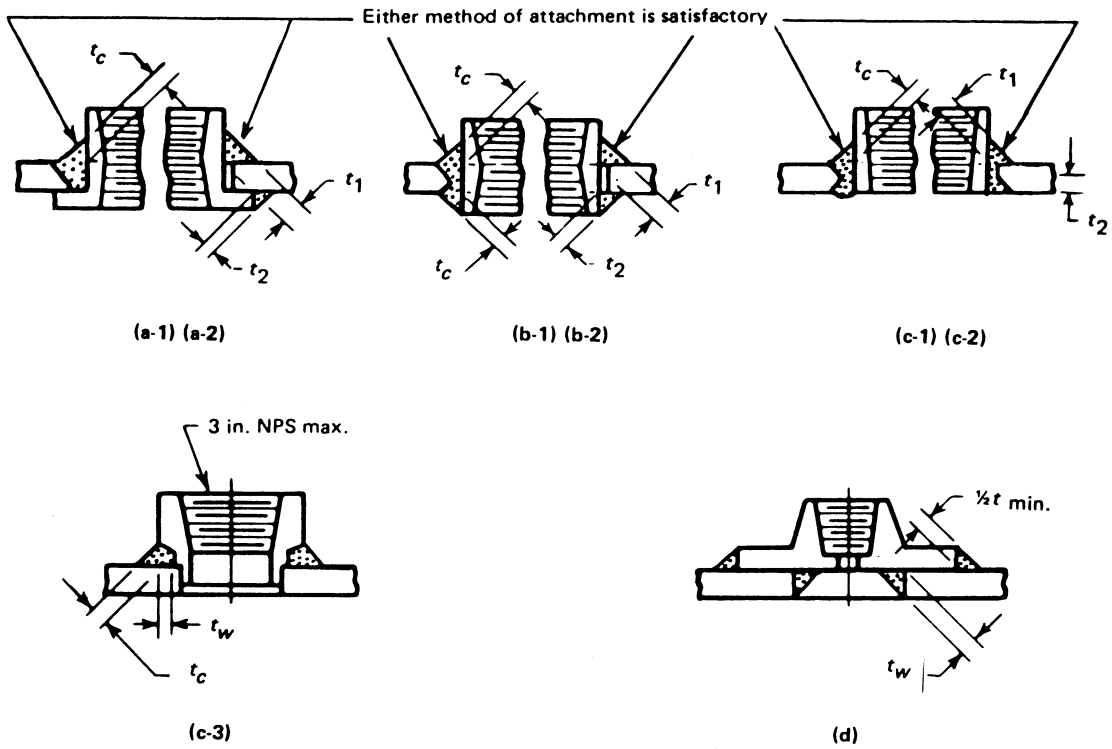

GENERAL NOTE: For definition of symbols, see NE-3352.4(e).

Figure NE-4244(e)-2
Acceptable Types of Small Fittings

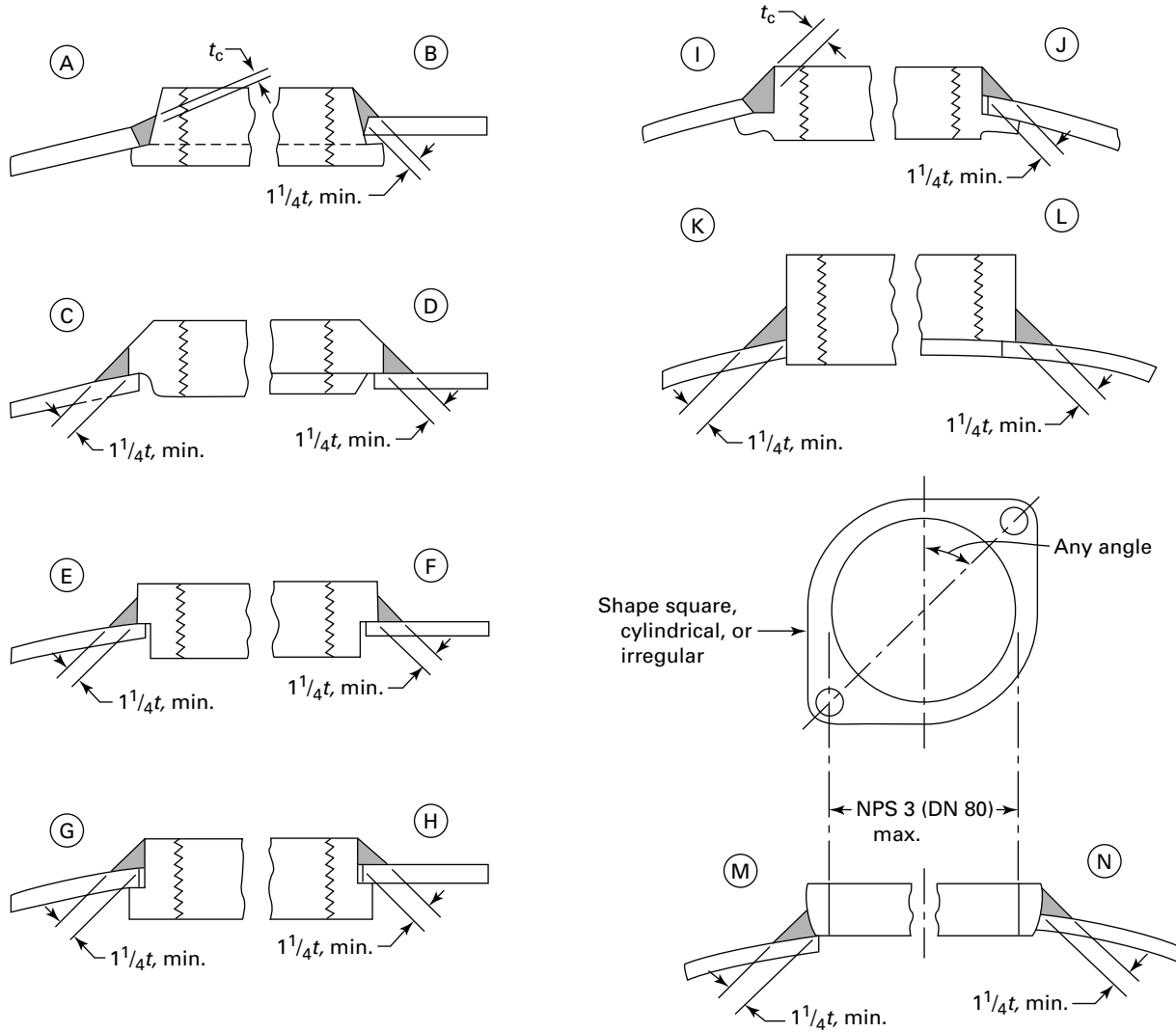

GENERAL NOTES:

- (a) Max. shell thickness = $\frac{3}{8}$ in. (10 mm)
- (b) Max. internal thread diameter = $3\frac{1}{2}$ in. (89 mm)
- (c) Max. dimension of opening in shell = no greater than $5\frac{3}{8}$ in. (135 mm) or $0.5 \times$ shell diameter

**Figure NE-4244(f)-1
Tube Connections**

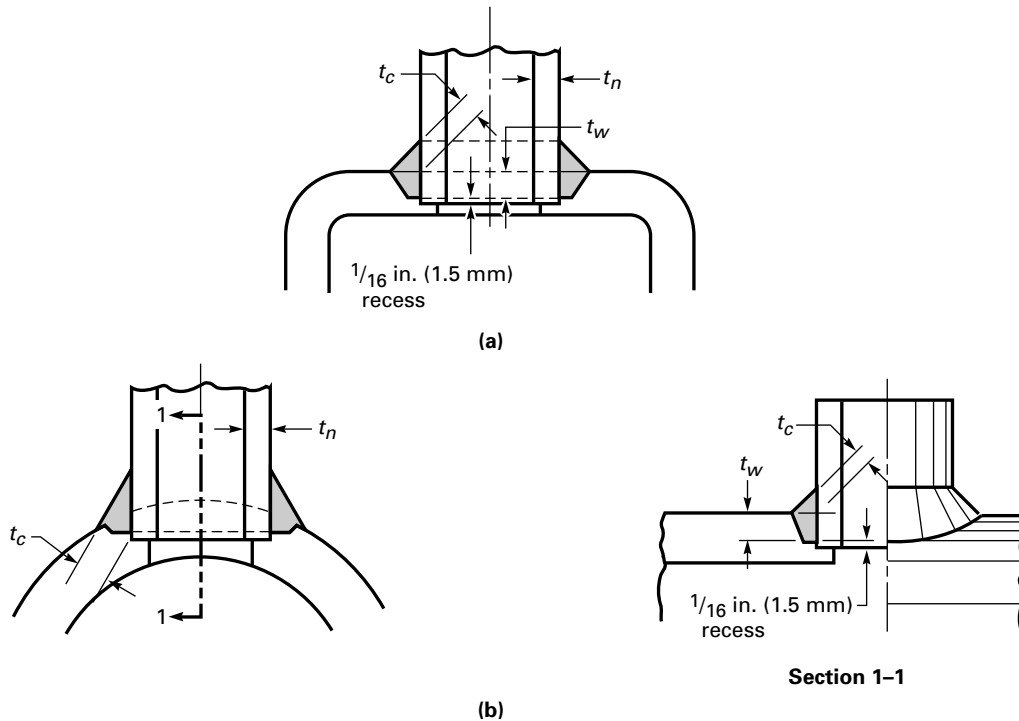

(c) When making procedure test plates for butt welds, consideration shall be given to the effect of angular, lateral, and end restraint on the weldment. This applies particularly to material and weld metal of 80.0 ksi (550 MPa) tensile strength or higher and heavy sections of both low and high tensile strength material. The addition of restraint during welding may result in cracking difficulties that otherwise might not occur.

NE-4322 Maintenance and Certification of Records

The Certificate Holder shall maintain a record of his qualified welding procedures and of the welders and welding operators qualified by him, showing the date and results of tests and the identification mark assigned to each welder. These records shall be reviewed, verified, and certified by the Certificate Holder by signature or some other method of control in accordance with the Certificate Holder's Quality Assurance Program and shall be available to the Authorized Nuclear Inspector.

NE-4322.1 Identification of Joints by Welder or Welding Operator.

(a) Each welder or welding operator shall apply the identification mark assigned to him by the Certificate Holder on or adjacent to all permanent welded joints or series of joints on which he welds. The marking shall be at intervals of 3 ft (1 m) or less and shall be

done with either blunt nose continuous or blunt nose interrupted dot die stamps. As an alternative, the Certificate Holder shall keep a record of permanent welded joints in each item, and of the welders and welding operators used in making each of the joints.

(b) When a multiple number of permanent structural attachment welds, nonstructural welds, fillet welds, socket welds, welds of specially designed seals, weld metal cladding, hard surfacing and tube-to-tubesheet welds, are made on an item, the Certificate Holder need not identify the welder or welding operator who welded each individual joint, provided:

(1) the Certificate Holder maintains a system that will identify the welders or welding operators who made such welds on each item so that the Inspector can verify that the welders or welding operators were all properly qualified;

(2) the welds in each category are all of the same type and configuration and are welded with the same welding procedure specification.

(c) The identification of welder or welding operator is not required for tack welds.

NE-4323 Welding Prior to Qualifications

No welding shall be undertaken until after the welding procedures which are to be used have been qualified. Only welders and welding operators who are qualified in accordance with [NE-4320](#) and Section IX shall be used.

NE-4324 Transferring Qualifications

The welding procedure qualifications and the performance qualification tests for welders and welding operators conducted by one Certificate Holder shall not qualify welding procedures and shall not qualify welders or welding operators to weld for any other Certificate Holder, except as provided in Section IX.

NE-4330 GENERAL REQUIREMENTS FOR WELDING PROCEDURE QUALIFICATION TESTS

NE-4331 Conformance to Section IX Requirements

All welding procedure qualification tests shall be in accordance with the requirements of Section IX as supplemented by the requirements of this Article.

NE-4333 Heat Treatment of Qualification Welds of Ferritic Material

Postweld heat treatment of procedure qualification welds shall conform to the applicable requirements of [NE-4600](#) and Section IX. The postweld heat treatment time at temperature shall be at least 80% of the maximum time to be applied to the weld material. The postweld heat treatment total time may be applied in one heating cycle.

NE-4334 Preparation of Test Coupons and Specimens

(a) Removal of test coupons from the test weld and the dimensions of specimens made from them shall conform to the requirements of Section IX, except that the removal of impact test coupons and the dimensions of impact test specimens shall be in accordance with (b) below.

(b) Weld deposit of each process in a multiple process weld shall, where possible, be included in the impact test specimens. When each process cannot be included in the full-size impact test specimen at the $\frac{1}{4}t$ location required by this Section, additional full-size specimens shall be obtained from locations in the test weld that will ensure that at least a portion of each process has been included in full-size test specimens. As an alternative, additional test welds can be made with each process so that full-size specimens can be tested for each process.

NE-4334.1 Coupons Representing the Weld Deposits. Impact specimen and testing methods shall conform to [NE-2321](#). The impact specimen shall be located so that the longitudinal axis of the specimen is at least $\frac{1}{4}t$,

and where the thickness of the test assembly permits, not less than $\frac{3}{8}$ in. (10 mm) from the weld surface of the test assembly. In addition, when the postweld heat treatment temperature exceeds the maximum temperature specified in [NE-4620](#), and the test assembly is cooled at an accelerated rate, the longitudinal axis of the specimen shall be a minimum of t from the edge of the test assembly. The specimen shall be transverse to the longitudinal axis of the weld with the area of the notch located in the weld. The length of the notch of the Charpy V-notch specimen shall be normal to the surface of the weld. Where drop weight specimens are required, the tension surface of the specimen shall be oriented parallel to the surface of the test weld assembly.

NE-4334.2 Coupons Representing the Heat-Affected Zone. Where impact tests of the heat-affected zone are required by [NE-4335.2](#), specimens shall be taken from the welding procedure qualification test assemblies in accordance with (a) through (c) below.

(a) If the qualification test material is in the form of a plate or a forging, the axis of the weld shall be oriented either parallel or perpendicular to the principal direction of rolling or forging.

(b) The heat-affected zone impact test specimens and testing methods shall conform to the requirements of [NE-2321.2](#). The specimens shall be removed from a location as near as practical to a depth midway between the surface and center thickness. The coupons for heat-affected zone impact specimens shall be taken transverse to the axis of the weld and etched to define the heat-affected zone. The notch of the Charpy V-notch specimen shall be cut approximately normal to the material surface in such a manner as to include as much heat-affected zone as possible in the resulting fracture. Where the material thickness permits, the axis of a specimen may be inclined to allow the root of the notch to align parallel to the fusion line. When a grain refining heat treatment is not performed on welds made by the electroslag or electrogas welding process, the notch for the impact specimens shall be located in the grain coarsened region.

(c) For the comparison of heat-affected zone values with base material values [[NE-4335.2\(b\)](#)], Charpy V-notch specimens shall be removed from the unaffected base material at approximately the same distance from the base material surface as the heat-affected zone specimens. The axis of the unaffected base material specimens shall be parallel to the axis of the heat-affected zone specimens, and the axis of the notch shall be normal to the surface of the base material.

NE-4335 Impact Test Requirements

When materials are required to be impact tested per [NE-2300](#), impact tests of the weld metal and heat-affected zone shall be performed in accordance with the following subparagraphs. Exemption from impact testing under

NE-2311(a)(8) does not apply for weld metal unless the specific weld metal used is included in Table NE-2311(a)-1. Exemption from impact testing of the heat-affected zone of those base materials exempted by NE-2311(a)(8) is not permitted. The weld procedure qualification impact test specimens shall be prepared and tested in accordance with the applicable requirements of NE-2330 and NE-4334. Retests in accordance with the provisions of NE-2350 are permitted.

NE-4335.1 Impact Tests of Weld Metal.

(a) Impact tests of the weld metal shall be required for welding procedure qualification tests for production weld joints exceeding $\frac{5}{8}$ in. (16 mm) in thickness when the weld is made on the surface or penetrates the base material that requires impact testing in accordance with NE-2310. In addition, such testing of the weld metal is required for the welding procedure qualification tests for any weld repair to base material that requires impact testing in accordance with NE-2310, regardless of the depth of the repair. Exemption from impact testing under NE-2311(a)(8) does not apply for weld metal of welding procedure qualification tests for either production weld joints or base material repairs, unless the specific weld metal used is included in Table NE-2311(a)-1.

(b) The impact test requirements and acceptance standards for welding procedure qualification weld metal shall be the same as specified in NE-2330 for the base material to be welded or repaired. Where two materials which have different fracture toughness requirements are to be joined by welding, the test requirements and acceptance standards of either material may be used for the weld metal, except where otherwise specified by NCA-1230 or other parts of this Section.

(c) A Welding Procedure Specification qualified to the impact testing requirements of Subsection NB or Subsection NC may be accepted as an alternative to the Welding Procedure Specification impact testing requirements of this Subsection.

NE-4335.2 Impact Tests of Heat-Affected Zone.

(a) Charpy V-notch tests of the heat-affected zone of the welding procedure qualification test assembly are required whenever the thickness of the weld exceeds $\frac{5}{8}$ in. (16 mm) and either of the base materials requires impact testing in accordance with the rules of NE-2310.

The only exceptions to the requirements are the following:

(1) the qualification for welds in P-No. 1 materials that are postweld heat treated and made by any process other than electroslag, electrogas, or thermit;

(2) the qualification for weld deposit cladding or hard-facing on any base material.

(3) that portion of the heat-affected zone associated with GTAW root deposits with a maximum of two layers of $\frac{3}{16}$ in. (5 mm) thickness, whichever is less.

(b) Charpy V-notch testing shall be performed as specified in (1) through (6).

(1) Charpy V-notch test specimens representing both the heat-affected zone and the unaffected base material shall be tested. The unaffected base material specimens shall be tested at a temperature equal to or below the lowest service temperature.

(2) The Charpy V-notch tests of the unaffected base material shall meet the applicable requirements of Table NE-2332.1-1 or Table NE-2332.1-2, as applicable, and Table NE-2333.1-1 when applicable, or additional testing shall be performed at higher temperatures until either of the above requirements are met.

(3) The heat-affected zone specimens shall be tested at the test temperature determined in (2). The applicable average toughness values of the heat-affected zone specimens shall equal or exceed the applicable average toughness values of the unaffected base material specimens, or the adjustment given in (4) through (6) shall be made. Alternatively, the production material impact tests shall be performed at 30°F (17°C) lower than required by NE-2331. As an additional alternative, another test coupon may be welded and tested.

(4) Additional Charpy V-notch tests shall be performed on either the heat-affected zone or the unaffected base material, or both, at temperatures where the applicable toughness values of all three specimens tested are not less than that specified in (2). The applicable average toughness values for each test meeting this requirement shall be plotted on a property-temperature graph. The difference in temperature T_{HAZ} and T_{UBM} , where the heat-affected zone and the unaffected base material applicable average toughness values are the same and not less than that specified in (2), shall be used to determine the adjustment temperature T_{ADJ} where:

$$T_{ADJ} = T_{HAZ} - T_{UBM}$$

If $T_{ADJ} \leq 0$, then $T_{ADJ} = 0$.

(5) As an alternative to (4), if the average toughness values of the heat-affected zone are no less than the values specified in Table NE-2332.1-1 or Table NE-2332.1-2, as applicable, and Table NE-2333.1-1, when applicable, and the average of the heat-affected zone specimens is not less than 7 ft-lb or 5 mils (0.13 mm) below the average toughness values of the unaffected base material, T_{ADJ} may be taken as 15°F (8°C).

(6) As a second alternative to (4), if the applicable toughness values of the heat-affected zone are no less than the values specified in Table NE-2332.1-1 or Table NE-2332.1-2, as applicable, and Table NE-2333.1-1, when applicable, the difference between the average applicable toughness values of the heat-affected zone and the unaffected base material shall be calculated and used as described in (c)(3) below.

(c) At least one of the following methods shall be used to compensate for the heat-affected zone toughness decrease due to the welding procedure.

(1) The lowest service temperature specified in the Design Specification for all material to be welded in production WPSs supported by this PQR shall be increased by the adjustment temperature T_{ADJ} .

(2) The specified testing temperature for the production material may be reduced by T_{ADJ} or 30°F (17°C).

(3) The materials to be welded may be welded using the WPS provided that they exhibit toughness values that are no less than the minimum required toughness value specified in [NE-2300](#) plus the difference in the applicable average toughness values established in [\(b\)\(6\)](#) above.

(d) The Charpy V-notch testing results shall be recorded on the PQR and any offsetting T_{ADJ} or increased toughness requirements shall be noted on the PQR and on the WPS. More than one compensation method may be used on a par basis.

(e) A Welding Procedure Specification qualified to the impact testing requirements of Subsection NB or Subsection NC may be accepted as an alternative to the Welding Procedure Specification impact testing requirements of this Subsection.

NE-4336 Qualification Requirements for Built-Up Weld Deposits

Built-up weld deposits for base metal reinforcement shall be qualified in accordance with the requirements of [NE-4331](#) through [NE-4335](#).

NE-4340 PERFORMANCE QUALIFICATION OF WELDERS FOR CLAD MATERIAL

NE-4341 General Requirements

A welder who has passed a test on composite welds in clad plate, as provided in [NE-4341.1](#), or as part of a procedure qualification test, as provided in [NE-4429.1\(a\)](#), is qualified for welding base metal and lining or cladding material separately. Likewise, a welder who has qualified on base metal and lining or cladding material separately is qualified to make composite welds. Qualification on both base plate and lining or cladding material is required only of welders who weld both materials.

NE-4341.1 Requirements for Composite Materials.

Performance qualification tests shall be made in accordance with Section IX by preparing test plates from clad material having the same P-Numbers in Section IX, Table QW-442 as that of the base plate and cladding material to be used in construction, and having the same F-Number in Section IX, Table QW-432 as the filler metal that will be used in construction. When the cladding material is not listed in Section IX, Table QW-442, qualification shall be made on the same grade as used in the vessel. Heat

treatment is not required but is permitted if the welder's work or construction is to be heat treated.

NE-4341.2 Requirements for Corrosion-Resistant Welds. Performance qualification tests for welding corrosion-resistant materials shall be the same as the procedure qualification tests described in [NE-4331](#).

NE-4400 RULES GOVERNING MAKING, EXAMINING, AND REPAIRING WELDS

NE-4410 PRECAUTIONS TO BE TAKEN BEFORE WELDING

NE-4411 Identification, Storage, and Handling of Welding Materials

Each Certificate Holder is responsible for control of the welding electrodes and other material that is used in the fabrication and installation of components ([NE-4120](#)). Suitable identification, storage, and handling of electrodes, flux, and other welding material shall be maintained. Precautions shall be taken to minimize absorption of moisture by electrodes and flux.

NE-4412 Cleanliness and Protection of Welding Surfaces

The method used to prepare the base metal shall leave the weld preparation with reasonably smooth surfaces. The surfaces for welding shall be free of scale, rust, oil, grease, and other deleterious material. The work shall be protected from deleterious contamination and from rain, snow, and wind during welding. Welding shall not be performed on wet surfaces.

NE-4420 RULES FOR MAKING WELDED JOINTS

NE-4421 Backing Rings

Backing rings shall conform to the requirements of [NE-4240](#). The material for backing rings, when used, shall be compatible with the base metal. Permanent backing rings, when permitted by [NE-4240](#), shall be continuous, and any splices shall be made by full penetration welds. Spacer pins shall not be incorporated into the welds.

NE-4422 Peening

Controlled peening may be performed to minimize distortion. Peening shall not be used on the initial layer root of the weld metal, nor on the final layer, unless the weld is postweld heat treated in accordance with [NE-4600](#).

NE-4423 Miscellaneous Welding Requirements

(a) Before applying weld metal on the second side to be welded, the root of full penetration double welded joints shall be prepared by suitable methods such as chipping, grinding, or thermal gouging, except for those processes of welding by which proper fusion and penetration are otherwise obtained and demonstrated to be satisfactory by welding procedure qualification.

(b) If the welding is stopped for any reason, extra care shall be taken in restarting to get the required penetration and fusion. For submerged arc welding, chipping out a groove in the crater is recommended.

(c) Where single-welded joints are used, particular care shall be taken in aligning and separating the components to be joined so that there will be complete penetration and fusion at the bottom of the joint for its full length.

NE-4424 Surfaces of Welds

As-welded surfaces are permitted. However, the surface of welds shall be sufficiently free from coarse ripples, grooves, overlaps, abrupt ridges, and valleys to meet (a) through (e) below.

(a) The surface condition of the finished weld shall be suitable for the proper interpretation of radiographic and other required nondestructive examinations of the welds. In those cases where there is a question regarding the surface condition on the interpretation of a radiographic film, the film shall be compared to the actual weld surface for interpretation and determination of acceptability.

(b) Reinforcements are permitted in accordance with NE-4426.

(c) Undercuts shall not exceed $\frac{1}{32}$ in. (0.8 mm) and shall not encroach on the required section thickness.

(d) Concavity on the root side of a single-welded circumferential butt weld is permitted when the resulting thickness of the weld meets the requirements of Article NE-3000.

(e) If the surface of the weld requires grinding to meet the above criteria, care shall be taken to avoid reducing the weld or base material below the required thickness.

NE-4425 Welding Components of Different Diameters

When components of different diameters are welded together, there shall be a gradual transition between the two surfaces in accordance with NE-3361. The length of the transition may include the weld.

NE-4426 Reinforcement of Welds

The surface of the reinforcement of all butt-welded joints in vessels may be flush with the base material or may have uniform crowns. The height of reinforcement on each face of the weld shall not exceed the following thickness:

Nominal Thickness, in. (mm)	Maximum Reinforcement, in. (mm)
Up to 1 (25), incl.	$\frac{3}{32}$ (2.5)
Over 1 to 2 (25 to 50), incl.	$\frac{1}{8}$ (3.0)
Over 2 to 3 (50 to 75), incl.	$\frac{5}{32}$ (4.0)
Over 3 to 4 (75 to 100), incl.	$\frac{7}{32}$ (5.5)
Over 4 to 5 (100 to 125), incl.	$\frac{1}{4}$ (6.0)
Over 5 (125)	$\frac{5}{16}$ (8.0)

NE-4427 Shape and Size of Fillet Welds

Fillet welds may vary from convex to concave. The shape and size of the weld shall be in accordance with the requirements of Figure NE-4427-1. A fillet weld in any single continuous weld may be less than the specified fillet weld dimension by not more than $\frac{1}{16}$ in. (1.6 mm), provided that the total undersize portion of the weld does not exceed 10% of the length of the weld. Individual undersize weld portions shall not exceed 2 in. (51 mm) in length. In making socket welds, a gap as shown in Figure NE-4427-1 shall be provided prior to welding. The gap need not be present nor be verified after welding.

NE-4428 Seal Welds of Threaded Joints

Where seal welding of threaded pipe joints is performed, the exposed threads shall be either removed entirely or covered with weld metal.

NE-4429 Welding of Clad Parts¹³

The joint types and welding procedures used for cladding shall be such as to prevent the formation of brittle weld composition.

NE-4429.1 Groove Welds in Clad Plate.

(a) The requirements in Section IX for procedure qualification shall be modified as follows for groove welds in clad plate.

(1) The requirements in Section IX, QW-403 and QW-404 shall apply separately to the base plate and to the cladding.

(2) The thicknesses specified in Section IX, Table QW-451 shall apply to the total thickness of clad plate.

(3) For material not included in Section IX, Table QW/QB-422, the material used in the test plate shall be within the range of chemical composition of that to be used in construction.

(b) The welding procedure for groove welds in integrally clad plate shall be qualified as provided in (a) above when any part of the cladding thickness of the clad plate is included in the design calculations in accordance with NE-3122.4(b). When the cladding thickness is not included in the design calculations, the procedure for groove welds may be qualified as in (a) above or the weld in the base plate joint may be qualified by itself in

**Figure NE-4427-1
Fillet and Socket Weld Details and Dimensions**

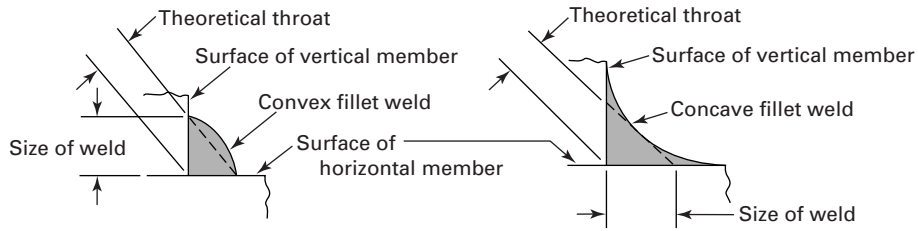

(a) Equal Leg Fillet Weld [Note (1)]

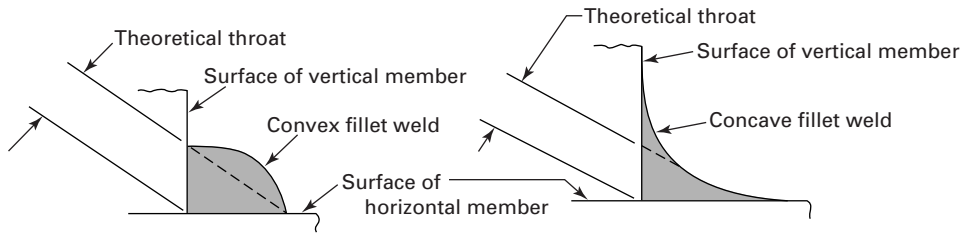

(b) Unequal Leg Fillet Weld [Note (2)]

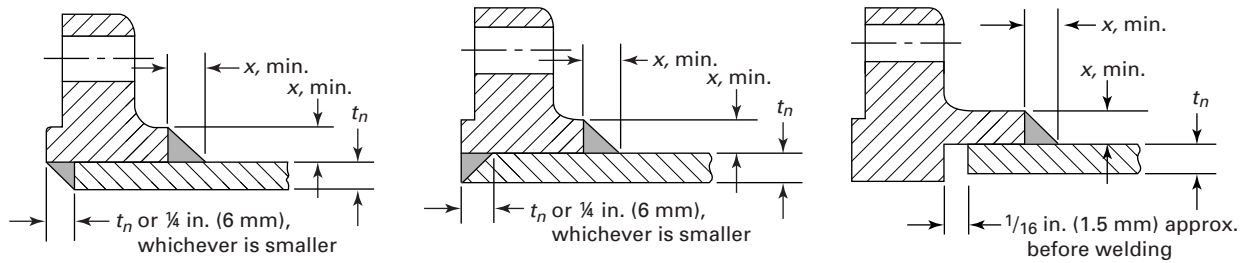

Front and back weld

Face and back weld

(c-1) Slip On Flange [Note (3)]

(c-2) Socket Welding Flange [Note (3)]

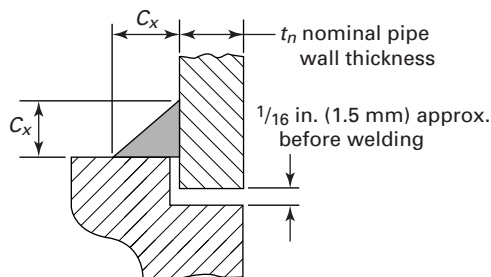

(c-3) Socket Welding Fittings [Note (4)]

NOTES:

- (1) The size of an equal leg fillet is the leg length of the largest inscribed right isosceles triangle. Theoretical throat = $0.7 \times$ size of weld.
- (2) The size of an unequal leg fillet weld is the shorter leg length of the largest right triangle that can be inscribed within the fillet weld cross section.
- (3) x min. = $1.4t_n$ or the thickness of the hub, whichever is smaller, but not less than $\frac{1}{8}$ in. (3 mm), where t_n = nominal pipe wall thickness.
- (4) C_x min. = $1.09t_n$ where t_n = nominal pipe wall thickness.

accordance with the rules in Section IX and the weld in the cladding joint by itself in accordance with [NE-4429.3](#).

NE-4429.2 Alloy Welds in Base Metal. Groove joints in base-metal plates and parts may be made with corrosion-resistant alloy-steel filler metal, or groove joints may be made between corrosion-resistant alloy steel and carbon or low alloy steel, provided the welding procedure and the welders have been qualified in accordance with the requirements of Section IX for the combination of materials used. Some applications of this rule are base metal welded with alloy-steel electrodes and alloy nozzles welded to shells.

NE-4429.3 Corrosion-Resistant Weld Deposits. Construction in which deposits of corrosion-resistant alloy weld metal are applied as a protective covering on the surface of base metal plates and parts and over welded base metal joints, whether adjacent or not to the edges of lining sheets or cladding material, shall be qualified in accordance with the rules given in (a) through (f) below.

(a) The qualification test plate shall consist of a base plate not less than 6 in. (150 mm) long, 3 in. (75 mm) wide, and $\frac{1}{4}$ in. (6 mm) thick, to which are clamped or bonded two strips of lining or cladding material separated by a gap left in the lining or a groove cut in the cladding. The gap or groove shall run lengthwise of the test plate, approximately midway of the plate width. The nominal thickness of the lining or cladding shall be within 20% plus or minus of the thickness to be used in construction.

(b) The requirements of Section IX, QW-403 and QW-404, shall apply separately to the base plate and the lining or cladding. For material not included in Section IX, Table QW/QB-422, the material used in the test plate shall be within the range of chemical composition of that to be used in construction.

(c) The width of gap shall be not less than twice the nominal thickness of the lining or cladding and not less than the maximum gap to be used in construction, but need not be greater than $\frac{3}{4}$ in. (19 mm) in order to qualify welding procedures in which corrosion-resistant weld metal is deposited in contact with base metal and adjacent lining or cladding material on two sides of a gap, as in welding the joints in linear sheets or clad plates.

(d) The width of a gap shall be not less than $\frac{3}{4}$ in. (19 mm) in order to qualify welding procedures in which corrosion-resistant weld metal is deposited in contact with base metal with lining or cladding material on one side only, as in layering corrosion-resistant weld metal on flange facings or in making fillet welds.

(e) The weld joint shall be made between the edges of the lining or cladding material by the procedure to be used in construction. The cooling of the test plate and any subsequent heat treatment shall follow the procedure to be used in construction.

(f) The tests to qualify the welding procedure shall be performed on two longitudinal bend test specimens that conform to the dimensions and other requirements of Section IX, QW-161 and Figure QW-462.3(b). The specimens shall be tested in accordance with, and meet the requirements of, Section IX, QW-162 and QW-163.

NE-4429.4 Fillet Welds. Fillet welds of corrosion-resistant metal deposited in contact with two materials of dissimilar composition may be used for connection attachments under the limitations of [NE-3359](#). The qualification of the welding procedures and welders to be used on fillet welds for a given combination of materials and alloy weld metal shall be made in accordance with [NE-4429.3](#) or, alternatively, by the rules prescribed in Section IX.

NE-4430 WELDING OF ATTACHMENTS

NE-4431 Materials for Attachments

Non-pressure-retaining attachments ([NE-1132.1](#)) welded to the containment vessel shall be of materials which meet the requirements of [NE-2190](#). Materials for pressure-retaining attachments shall meet the requirements of [NE-2120](#).

NE-4432 Welding of Structural Attachments

The rules of [NE-4321](#) governing welding qualifications shall apply to the welding of structural attachments to pressure-retaining material.

NE-4433 Structural Attachments

Structural attachments shall conform reasonably to the curvature of the shell or surface to which they are attached, and may be attached by either full penetration, fillet, or partial penetration continuous or intermittent welds.

NE-4434 Welding of Internal Structural Supports to Clad Components

Internal structural supports on cladding surfaces shall be welded to the base metal and not to the cladding, except for weld overlay cladding.

NE-4435 Welding of Nonstructural Attachments and Their Removal

(a) Nonstructural attachments ([NE-1132.1](#)) welded to the pressure-retaining portion of the containment vessel need not comply with [Article NE-2000](#) and may be welded with continuous or intermittent fillet or partial penetration welds, provided the requirements of (1) through (4) below are met:

(1) the welding procedure and the welders have been qualified in accordance with [NE-4321](#);

Figure NE-4437(b)-1
Attachment of Stiffening Rings to Shell

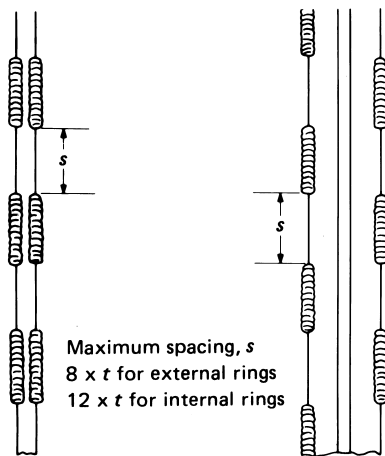

(2) the material is identified and is compatible with the material to which it is attached;

(3) the welding material is identified and compatible with the materials joined;

(4) the welds are postweld heat treated when required by NE-4620.

(b) Removal of nonstructural temporary attachments shall be accomplished as follows:

(1) The temporary attachment is completely removed in accordance with the procedures of NE-4211.

(2) As an alternative to (a)(4) above, postweld heat treatment may be deferred until after removal of the attachment.

NE-4437 Attachment of Stiffening Rings to Shell

(a) Stiffening rings, when used, may be placed on the inside or outside of a vessel and shall be attached to the shell by welding or bolting. The ring shall be in contact with the shell.

(b) Stiffening rings may be attached to the shell either by continuous or intermittent welding. The total length of the intermittent welding on each side of the stiffening ring shall be:

(1) not less than one-half the outside circumference of the vessel for rings on the outside; and

(2) not less than one-third of the circumference of the vessel for rings on the inside.

Acceptable arrangements and spacing of intermittent welds are shown in Figure NE-4437(b)-1. Welds on opposite sides of the stiffener may be either staggered or in-line as indicated.

(c) All welding of stiffening rings shall comply with the requirements of this Subsection. In areas where a corrosion allowance is specified in the Design Specification, stiff-

ening rings shall be attached to the shell with a continuous fillet, seal, or full penetration weld.

NE-4450 REPAIR OF WELD METAL DEFECTS

NE-4451 General Requirements

Defects in weld metal detected by the examinations required by Article NE-5000, or by the tests of Article NE-6000, shall be eliminated and when necessary repaired.

NE-4452 Elimination of Surface Defects

Weld metal surface defects may be removed by grinding or machining and not repaired by welding provided that the requirements of (a) through (c) below are met:

(a) the remaining thickness of the section is not reduced below that required by Article NE-3000;

(b) the depression, after defect elimination, is blended uniformly into the surrounding surface;

(c) the area is examined by a magnetic particle or liquid penetrant method in accordance with NE-5110 after blending and meets the acceptance standards of NE-5300 to ensure that the defect has been removed or the indication reduced to an acceptable limit. Defects detected by the visual or volumetric method and located on an interior surface need only be reexamined by the method which initially detected the defect when the interior surface is inaccessible for surface examination.

NE-4453 Requirements for Making Repairs to Welds

Excavations in weld metal, when repaired by welding, shall meet the requirements of the following subparagraphs.

NE-4453.1 Defect Removal. Defects may be removed by mechanical means or by thermal gouging processes. The area prepared for repair shall be examined by a liquid penetrant or magnetic particle method in accordance with NE-5110 and meet the acceptance standards of NE-5340 or NE-5350. This examination is not required where defect elimination removes the full thickness of the weld and where the backside of the weld joint is not accessible for removal of examination materials.

NE-4453.2 Requirements for Welding Material, Procedures, and Welders. The weld repair shall be made using welding material, welders, and welding procedures qualified in accordance with NE-4125 and NE-4300.

NE-4453.3 Blending of Repaired Areas. After repair the surface shall be blended uniformly into the surrounding surface.

NE-4453.4 Examination of Repair Welds. The examination of a weld repair shall be repeated as required for the original weld, except that it need only be reexamined

by the liquid penetrant or magnetic particle method when the unacceptable indication was originally detected by the liquid penetrant or magnetic particle method and when the repair cavity does not exceed the following:

- (a) $\frac{1}{3}t$ for $t \leq \frac{3}{4}$ in. (19 mm)
- (b) $\frac{1}{4}$ in. (6 mm) for $\frac{3}{4}$ in. (19 mm) $< t \leq 2\frac{1}{2}$ in. (64 mm)
- (c) the lesser of $\frac{3}{8}$ in. (10 mm) or 10% t for $t > 2\frac{1}{2}$ in. (64 mm)

where t equals the thickness of the weld.

NE-4453.5 Heat Treatment of Repaired Areas. The area shall be heat treated in accordance with [NE-4620](#).

NE-4454 Inserted Strips in Clad Material

The thickness of inserted strips used to restore cladding at joints shall be equal to that of the nominal minimum thickness of cladding specified for the plates backed, if necessary, with corrosion-resistant weld metal deposited in the groove to bring the insert flush with the surface of the adjacent cladding.

NE-4600 HEAT TREATMENT

NE-4610 WELDING PREHEAT REQUIREMENTS

NE-4611 When Preheat Is Necessary

The need for and temperature of preheat are dependent on a number of factors, such as the chemical analysis, degree of restraint of the parts being joined, elevated temperature, physical properties, and material thicknesses. Some practices used for preheating are given in Section III Appendices, Nonmandatory Appendix D as a general guide for the materials listed by P-Numbers of Section IX. It is cautioned that preheating suggested in Section III Appendices, Nonmandatory Appendix D does not necessarily ensure satisfactory completion of the welded joint and that the preheating requirements for individual materials within the P-Number listing may be more or less restrictive. The Welding Procedure Specification for the material being welded shall specify the minimum preheating requirements under the welding procedure qualification requirements of Section IX.

NE-4612 Preheating Methods

Preheat for welding or thermal cutting, when employed, may be applied by any method which does not harm the base material or any weld metal already applied, or which does not introduce deleterious material into the welding area which is harmful to the weld.

NE-4613 Interpass Temperature

Consideration shall be given to the limitations of interpass temperatures for quenched and tempered material to avoid detrimental effects on the mechanical properties.

NE-4620 POSTWELD HEAT TREATMENT

NE-4621 Heating and Cooling Methods

Postweld heat treatment (PWHT) may be accomplished by any suitable methods of heating and cooling, provided the required heating and cooling rates, metal temperature, metal temperature uniformity, and temperature control are maintained.

NE-4622 PWHT Time and Temperature Requirements

NE-4622.1 General Requirements.² The requirements for postweld heat treatment are given in (a), (b), and (c) below.

(a) Except as otherwise permitted in [NE-4622.7](#), all welds, including repair welds, shall be postweld heat treated. During postweld heat treatment, the metal temperatures shall be maintained with the temperature ranges and for the minimum holding times specified in [Table NE-4622.1-1](#), except as otherwise permitted in [NE-4622.4\(c\)](#). P-Number groups in [Table NE-4622.1-1](#) are in accordance with Section IX, QW-420. Except as provided in [NE-4624.3](#), PWHT shall be performed in temperature-surveyed and -calibrated furnaces, or PWHT shall be performed with thermocouples in contact with the material or attached to blocks in contact with the material.

(b) Unless exempted in [Table NE-4622.7\(b\)-1](#), all doors, nozzles, opening frames, and similar welded construction shall be welded into a portion of the shell plate or plates, and the welded subassembly shall be postweld heat treated prior to welding into the shell.

(c) The requirements of the following subparagraphs shall also apply.

NE-4622.2 Time-Temperature Recordings. Time-temperature recordings of all postweld heat treatments shall be made available for review by the Authorized Inspector. Identification on the time-temperature recording shall be to the weld, part, or vessel. A summary of the time-temperature recording may be provided for permanent records in accordance with NCA-4134.17.

NE-4622.3 Definition of Nominal Thickness Governing PWHT. Nominal thickness in [Table NE-4622.7\(b\)-1](#) is the thickness of the weld, the pressure-retaining material for structural attachment welds or the thinner of the pressure-retaining materials being joined, whichever is least. It is not intended that nominal thickness include material provided for forming allowance, thinning, or mill overrun when the excess material does not exceed $\frac{1}{8}$ in. (3 mm). For fillet welds the nominal thickness is the throat thickness, and for partial penetration and material repair welds the nominal thickness is the depth of the weld groove or penetration.

Table NE-4622.1-1
Mandatory Requirements for Postweld Heat Treatment (PWHT) of Welds

P-Number (Sect. IX, QW-420)	Holding Temperature Range, °F (°C) [Note (1)]	Minimum Holding Time at Temperature for Weld Thickness (Nominal)		
		½ in. (13 mm) or less	Over ½ in. to 2 in. (Over 13 mm to 50 mm)	Over 2 in. (50 mm)
1	1,100–1,250 (595–675)	30 min	1 hr/in. (2 min/mm)	2 hr plus 15 min each additional inch (2 h plus 0.5 min/mm) over 2 in. (50 mm)
8, 34, 42, 43, 45	PWHT neither required nor prohibited			

GENERAL NOTE: Exemption to the mandatory requirements of this Table are defined in [NE-4622.7](#).

NOTE: (1) All temperatures are metal temperatures.

NE-4622.4 Holding Times at Temperature.

(a) The holding time at temperature as specified in [Table NE-4622.1-1](#) shall be based on the nominal thickness of the weld. The holding time need not be continuous. It may be an accumulation of the times of multiple postweld heat treatment cycles.

(b) Holding time at temperature in excess of the minimum requirements of [Table NE-4622.1-1](#) may be used, provided that specimens so heat treated are tested in accordance with [NE-2200](#), [NE-2400](#), and [NE-4300](#).

(c) Alternatively, when it is impractical to postweld heat treat at the temperature range specified in [Table NE-4622.1-1](#), it is permissible to perform the postweld heat treatment of certain materials at lower temperatures for longer periods of time in accordance with [Table NE-4622.4\(c\)-1](#) and (1) below.

(1) Base materials certified in accordance with [NE-2200](#) may be postweld heat treated at these lower minimum temperatures and increased minimum holding times without recertification. Postweld heat treatment at these lower minimum temperatures and increased minimum holding times may also be the tempering operation, provided a higher tempering temperature is not required by the material specification.

Table NE-4622.4(c)-1
Alternative Holding Temperatures and Times

Material P-Numbers	Alternative Holding Temperature Range, °F (°C)	Alternative Minimum Holding Times
1	1,050 (565)	2 hr/in. (4 min/mm) thick
1	1,000 (540)	4 hr/in. (8 min/mm) thick

GENERAL NOTE: All other requirements of [NE-4622](#) shall apply.

NE-4622.5 PWHT Requirements When Different P-Number Materials Are Joined. Postweld heat treatment is not required when joining P-No. 1 material 1½ in. (38 mm) or less in thickness to P-No. 8, P-No. 42, P-No. 43, or P-No. 45 materials with electrodes that produce austenitic or non-air-hardening nickel-chromium-iron deposits.

NE-4622.6 PWHT Requirements for Non-Pressure-Retaining Parts. When non-pressure-retaining material is welded to pressure-retaining material, the postweld heat treatment temperature range of the pressure-retaining material shall control.

NE-4622.7 Exemptions to Mandatory Requirements. Postweld heat treatment in accordance with this subarticle is not required for:

- (a) nonferrous materials;
- (b) welds exempted in [Table NE-4622.7\(b\)-1](#);
- (c) welds subjected to temperatures above the PWHT temperature range specified in [Table NE-4622.1-1](#), provided the Welding Procedure Specification is qualified in accordance with Section IX and the base material and the deposited weld material have been heat treated at the higher temperature;
- (d) extensions and the welds joining these extensions to nozzles, opening frames, and similar construction, provided all other requirements of [NE-4620](#) are met and the weld is located at least $0.5\sqrt{rt}$ from the surface of the vessel, where r is the mean radius of the nozzle or opening and t is the nominal thickness of the nozzle or opening;
- (e) nonpressure parts attached to pressure parts which have been previously postweld heat treated, provided the attachment welds meet the requirements of [Table NE-4622.7\(b\)-1](#).

NE-4623 PWHT Heating and Cooling Rate Requirements

Above 800°F (425°C) the rate of heating and cooling in any hourly interval shall not exceed 400°F (222°C) divided by the maximum thickness in inches of the material being

**Table NE-4622.7(b)-1
Exemptions to Mandatory PWHT**

P-Number, (Section IX, QW-420)	Type of Weld [Note (1)]	Nominal Thickness, in. (mm) (NE-4622.3)	Max. Reported Carbon, % [Note (2)]	Min. Preheat Required, °F (°C)
1	All welds where the materials being joined are 1½ in. (38 mm) and less, exclusive of welds joining nozzles or penetrations with an I.D. greater than 2 in. (50 mm) to the vessel shell	1¼ (32) or less Over 1¼ to 1½ (32 to 38) ¾ (19) or less Over ¾ to 1½ (19 to 38)	0.30 or less 0.30 or less Over 0.30 Over 0.30	... 200 (95) ... 200 (95)
	All welds joining nozzles and penetrations with an I.D. greater than 2 in. (50 mm) to the vessel shell provided all of the following are satisfied: (a) the shell thickness does not exceed 1½ in. (38 mm), (b) the size does not exceed NPS 12 (DN300), (c) the ratio of major to minor diameter of non-circular openings does not exceed 1.15, and (d) the weld is at least 1.0 (Rt) ^{1/2} from any other non-postweld heat-treated weld in the vessel shell.	1¼ (32) or less Over 1¼ to 1½ (32 to 38) ¾ (19) or less Over ¾ to 1½ (19 to 38)	0.30 or less 0.30 or less Over 0.30 Over 0.30	... 200 (95) ... 200 (95)
	All welds in material over 1½ in. (38 mm), exclusive of welds joining nozzles or penetrations to the vessel shell	¾ (19) or less	...	200 (95)
	All welds, including repair welds in material greater than 1½ in. (38 mm), but equal to or less than 1¾ in. (44 mm) exclusive of welds joining nozzles or penetrations to the vessel shell [Note (3)]	1¾ (44) or less	0.24	200 (95)
	All welds joining nozzles or penetrations with a nominal I.D. of 2 in. (50 mm) and less	¾ (19) or less	...	200 (95)
	Repairs to welds in subassemblies postweld heat treated as required by NE-4622.1(b) with the total accumulated repair length of any weld not exceeding 25% of the original weld length	1¾ (44) or less	...	200 (95)
	1 Gr. 1 or Gr. 2	Cladding or repair of cladding [Note (4)] with A-No. 8 or F-No. 43 filler metal in base material of: – 1½ in. (38 mm) or less – Over 1½ in. to 3 in. (38 mm to 75 mm) – Over 3 in. (75 mm)	0.30 0.30 0.30

GENERAL NOTE: The exemptions noted in this Table do not apply to electron beam welds in ferritic materials over 1/8 in. (3 mm) in thickness.

NOTES:

- (1) Where the thickness of material is identified in the Type of Weld column, it is the thickness of the thicker of the base materials at the welded joint.
- (2) Carbon level of the pressure-retaining materials being joined.
- (3) This exemption is limited to SA-299, SA-516, SA-537, and SA-738 materials, under the following conditions:
 - (a) The exemption from impact testing as provided in NE-2311(a)(8) is not permitted.
 - (b) For Charpy V Notch Testing per NE-2331(a)(1), the testing criteria are as described in either of the following:
 - (1) The testing temperature is 10°F (5.6°C) below the Lowest Service Metal Temperature, and the C_v energy values are as shown in Table NE-2332.1-2.
 - (2) The testing temperature is the Lowest Service Metal Temperature, and the C_v energy values are increased by 5 ft-lb (7 J) over those shown in Table NE-2332.1-2.
 - (c) For Drop Weight Testing permitted by NE-2331(a)(2), the difference between Lowest Service Metal Temperature and the nil ductility transition temperature, (LSMT – T_{N_{DT}}), is equal to or greater than 10°F + A (5.6°C + A), in which the value of A is determined in accordance with Section III Appendices, Nonmandatory Appendix R.
- (4) The maximum resulting hardness of the heat-affected zone in the procedure qualification test plate shall not exceed 35 Rc.
- (5) Intermediate postweld soak at not less than 200°F (95°C) for 2-hr min.
- (6) Intermediate postweld soak at not less than 300°F (150°C) for 2-hr min.

heat treated, but shall not exceed 400°F (222°C) and need not be less than 100°F (56°C) in any hourly interval. During the heating and cooling period there shall not be a greater variation in temperature than 250°F (139°C) within any 15 ft (5 m) interval of weld length.

NE-4624 Methods of Postweld Heat Treatment

The postweld heat treatment shall be performed in accordance with the requirements of one of the following subparagraphs.

NE-4624.1 Furnace Heating — One Heat. Heating the vessel or item in a closed furnace in one heat is the preferred procedure and should be used whenever practical. The furnace atmosphere shall be controlled so as to avoid excessive oxidation, and direct impingement of flame on the vessel or item is prohibited.

NE-4624.2 Furnace Heating — More Than One Heat. The vessel or item may be heated in more than one heat in a furnace, provided the furnace atmosphere control requirements of [NE-4624.1](#) apply and overlap of the heated sections of the vessel or item is at least 5 ft (2 m). When this procedure is used, the portion of the vessel or item outside the furnace shall be shielded so that the temperature gradient is not harmful. The cross section where the vessel or item projects from the furnace shall not intersect a nozzle or other structural discontinuity.

NE-4624.3 Local Heating. Welds may be locally postweld heat treated when it is not practical to heat treat the entire vessel or item. Local postweld heat treatment shall consist of heating a circumferential band around the vessel or item at temperatures within the ranges specified in this subarticle. The minimum width of the controlled band at each side of the weld, on the face of the greatest weld width, shall be the thickness of the weld or 2 in. (50 mm), whichever is less. The temperature of the vessel or item from the edge of the controlled band outward shall be gradually diminished so as to avoid harmful thermal gradients. This procedure may also be used for postweld heat treatment after repairs.

NE-4624.4 Heating Vessels Internally. The vessel or item may be heated internally by any appropriate means and with adequate indicating and recording temperature devices to aid in the control and maintenance of a uniform distribution of temperature in the vessel or item. Prior to this operation, the vessel or item shall be fully enclosed with insulating material.

NE-4630 INTERMEDIATE POSTWELD HEAT TREATMENT

The temperature, time-at-temperature, and heating and cooling rate requirements of [NE-4620](#) are not mandatory for intermediate heat treatments.

NE-4660 HEAT TREATMENT OF ELECTROSLAG WELDS

Electroslag welds in ferritic material over 1½ in. (38 mm) in thickness at the joints shall be given a grain refining heat treatment.

NE-4700 MECHANICAL JOINTS AND PENETRATION ASSEMBLIES

NE-4710 BOLTING AND THREADING

NE-4711 Thread Engagement

The threads of all bolts or studs shall be engaged in accordance with the design.

NE-4712 Thread Lubricants

Any lubricant or compound used in threaded joints shall be suitable for the service conditions and shall not react unfavorably with either the service fluid or any material in the system.

NE-4713 Removal of Thread Lubricants

All threading lubricants or compounds shall be removed from surfaces which are to be seal welded.

NE-4714 Stud Threading

Studs shall be threaded full length or shall be machined down to the root diameter of the thread in the unthreaded portion.

NE-4720 BOLTING FLANGED JOINTS

In bolting gasketed flanged joints, the contact faces of the flanges shall bear uniformly on the gasket and the gasket shall be properly compressed in accordance with the design principles applicable to the type of gasket used. All flanged joints shall be made up with relatively uniform bolt stress.

NE-4730 ELECTRICAL AND MECHANICAL PENETRATION ASSEMBLIES

(a) Electrical and mechanical penetration assemblies, except for those portions performing an electrical conducting or insulating function, shall be constructed in accordance with the rules for containment vessels.

(b) Tubes or pipe of NPS 2 (DN 50) and less may be joined to a penetration assembly in accordance with the rules of [NE-4740](#).

(c) The closing seam for the penetration assembly may be made with a multipass single lap fillet weld as shown in [Figure NE-4730-1](#), provided the requirements of (1) through (5) below are met:

(1) one of the heads on the penetration assembly meets the requirements of [NE-3352.3](#);

**Figure NE-4730-1
Penetration Assembly**

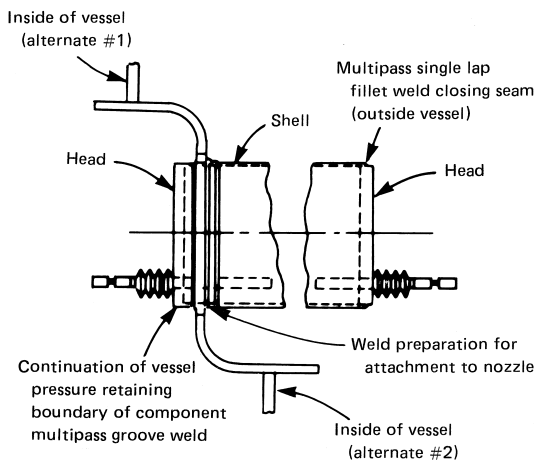

(2) the penetration assembly shall not exceed 18 in. (450 mm) O.D.;

(3) the design pressure of the penetration assembly shall not exceed 100 psi (700 kPa) and the design temperature shall not exceed 400°F (205°C);

(4) examination of the fillet weld shall be by the liquid penetrant method in accordance with NE-5350;

(5) the fillet weld and closure head shall meet the requirements of NE-3720(b).

NE-4740 SPECIAL QUALIFICATION REQUIREMENTS FOR ELECTRICAL AND MECHANICAL PENETRATION ASSEMBLIES

NE-4741 General Requirements

These rules are applicable only for the attachment of pipes and tubes of NPS 2 (DN 50) and less to electrical and mechanical penetration assemblies as permitted in NE-4730. The welding procedure shall be qualified as a new procedure specification and shall be completely requalified when any of the changes listed below are made in the procedure. Changes other than those so given may be made in a procedure without the necessity for requalification, provided the procedure specification is amended to show these changes.

NE-4742 Essential Variables for All Welding Processes

Essential variables for all welding processes shall be as listed in (a) through (k) below:

(a) a change from one welding process to any other welding process or combination of welding processes;

(b) a change in the P-Number classification of pipe or tube material in Section IX, Tables QW-442 and QW/QB-422; a separate qualification is required for each pipe or tube material which is not included under any P-Number;

(c) a change in the P-Number of the penetration assembly:

(1) the base material may be a homogeneous material or a cladding material of wrought-type or weld-overlay-type; if welding is performed between the pipe or tube and cladding, the cladding shall be considered the base material; a separate qualification is required for welding pipes or tubes to base material or cladding material which is not included under any P-Number;

(d) changes in the weld metal analysis of the deposited weld metal as given in (1) and (2) below:

(1) a change from any A-Number in Section IX, Table QW-442, to any other A-Number or to any F-Number in Section IX, Table QW-432 or to any analysis not listed in the tables, except that each AISI type similar to A-No. 7 or A-No. 8 of Section IX, Table QW-442 shall require separate qualifications;

(2) a change from any F-Number in Section IX, Table QW-432 to any other F-Number or to any A-Number in Section IX, Table QW-442 or to any analysis not listed in the tables;

(e) for pipes or tubes of specified wall thickness of 0.100 in. (2.54 mm) or less, an increase or decrease of 10% of specified wall thickness or specified diameter;

(f) for specified wall thicknesses greater than 0.100 in. (2.54 mm), only one qualification test is required;

(g) a decrease of 10% or more in the specified width of the ligament between holes when the specified width of the ligament is less than the greater of $\frac{3}{8}$ in. (10 mm) or three times the specified pipe or tube wall thickness;

(h) the addition of other welding positions than those already qualified (Section IX, Figure QW-461.1);

(i) a change in the specified preheating temperature range;

(j) a change in the specified postweld heat treating temperature;

(k) a change from multiple pass to single pass or vice versa.

NE-4743 Essential Variables for Shielded Metal-Arc Welding

Additional essential variables for shielded metal-arc welding are as given in (a) and (b) below:

(a) an increase in electrode diameter;

(b) a change from one F-Number in Section IX, Table QW/QB-422 or Table QW-432, to any other F-Number (Notes 2 and 3 in Section IX, Table QW-432 shall apply).

**Figure NE-4810(c)-1
Bellows Attachment Welds**

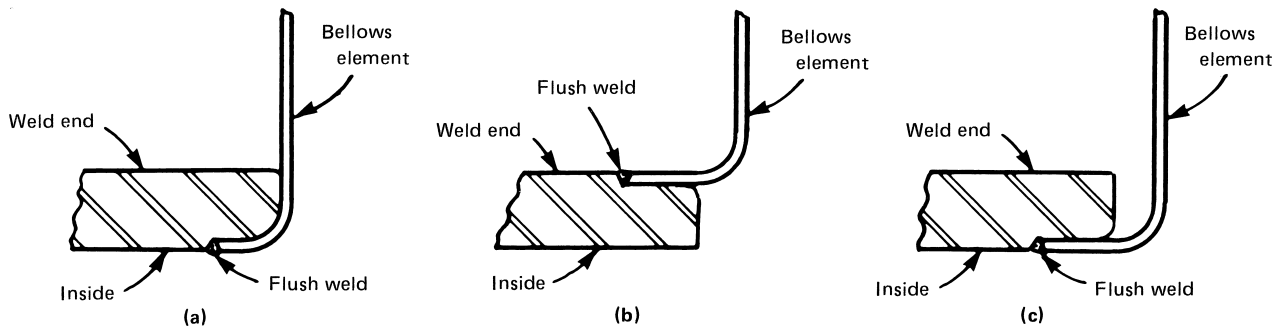

NE-4744 Essential Variables for Gas Tungsten-Arc and Gas Metal-Arc Welding

Additional essential variables for gas tungsten-arc and gas metal-arc welding are as given in (a) through (f) below:

(a) a change in the configuration of the penetration assembly at the hole edges, including the addition or omission of preplaced metal inserts;

(b) a change in the size or shape of preplaced metal inserts;

(c) a change from one shielding gas to another shielding gas or to a mixture of shielding gases;

(d) when using mixed shielding gas, a change of $\pm 25\%$ or $5 \text{ ft}^3/\text{hr}$ ($0.14 \text{ m}^3/\text{hr}$), whichever is the larger, in the rate of flow of the minor gas constituent;

(e) for gas tungsten-arc welding process, the addition or omission of filler metal;

(f) a change in the nominal diameter of the filler metal.

NE-4745 Test Assembly

The procedure qualification shall be made on a test assembly which simulates the conditions to be used in production with respect to the hole pattern and the essential variables listed in NE-4741. In addition, the thickness of the test assembly at the holes shall be as thick as the production penetration assembly at the holes, except that it need not exceed 2 in. (50 mm). The minimum required number of weld joints shall be ten.

NE-4746 Examination of Test Assembly

The test assembly shall be examined by a liquid penetrant method in accordance with the requirements of NE-5110 and shall meet the acceptance standards of NE-5350. Following this, the test assembly shall be sectioned longitudinally through each pipe or tube. The thickness of the test assembly may be reduced to $\frac{1}{2}$ in.

(13 mm) prior to this sectioning. The four faces of each pipe or tube exposed by sectioning shall be polished and etched with a suitable etchant and shall be visually examined for cracks. The weld throat, minimum leakage path, shall be not less than two-thirds of the specified pipe or tube wall thickness, and the weld shall be free from cracks on visual examination with $\times 10$ magnification.

NE-4747 Performance Qualification Test

The requirements for the performance qualification test for welders and welding operators shall be the same as those for the procedure qualification, except that the minimum required number of tubes in the test assembly shall be six. Any welder or welding operator who makes a procedure test that passes satisfactorily is thereby qualified.

NE-4800 EXPANSION JOINTS

NE-4810 BELLOWS-TYPE EXPANSION JOINTS

For bellows-type expansion joints the requirements of (a) through (e) below shall be met.

(a) All welded joints shall comply with the requirements of NE-4400.

(b) The longitudinal weld in the bellows shall be a butt-type full penetration weld.

(c) The bellows element of the expansion joint shall be attached to the welding ends or flange by circumferential welds of a butt type having full penetration weld through the thickness of the bellows portion, as shown in Figure NE-4810(c)-1.

(d) Other than the attachment welds, no circumferential welds are permitted in the bellows elements.

(e) Weld repairs shall not be permitted on parent material of bellows elements.

ARTICLE NE-5000 EXAMINATION

NE-5100 GENERAL REQUIREMENTS FOR EXAMINATION OF VESSELS

NE-5110 PROCEDURES, QUALIFICATIONS, AND EVALUATION

NE-5111 General Requirements

Nondestructive examinations shall be conducted in accordance with the examination methods of Section V, except as they may be modified by the requirements of this Article. Radiographic examination shall be in accordance with Section V, Article 2, except that the geometric unsharpness shall not exceed the limits of Section V, Article 2, T-274.2. Ultrasonic examination shall be in accordance with Section V, Article 4; magnetic particle examination shall be in accordance with Section V, Article 7; and liquid penetrant examination shall be in accordance with Section V, Article 6. The examinations required by this Article or by reference to this Article shall be performed by personnel who have been qualified as required by this Article. The results of the examinations shall be evaluated in accordance with the acceptance standards of this Article.

NE-5112 Nondestructive Examination Procedures

All nondestructive examinations required by this Article shall be performed in accordance with detailed written procedures which have been proven by actual demonstration to the satisfaction of the Inspector. The procedures shall comply with the appropriate Article of Section V for the particular examination method. The digitization of radiographic film and radiosopic images shall meet the requirements of Section V, Article 2, Mandatory Appendix III, "Digital Image Acquisition, Display, and Storage for Radiography and Radioscopy." Written procedures and records of demonstration of procedure capability and personnel qualification shall be made available to the Inspector on request. At least one copy of the procedure shall be readily available to all applicable nondestructive examination personnel for reference and use.

NE-5113 Post-Examination Cleaning

Following any nondestructive examination in which examination materials are applied to the piece, the piece shall be thoroughly cleaned in accordance with applicable material or procedure specifications.

NE-5120 TIME OF EXAMINATION OF WELDS

Acceptance examination of welds required by NE-5200 shall be performed at the times stipulated in (a), (b), and (c) below.

(a) Radiographic examination of all welds in vessels may be performed prior to any required postweld heat treatment.

(b) Magnetic particle or liquid penetrant examinations shall be performed after any required postweld heat treatment, except that welds in P-No. 1 material may be examined either before or after postweld heat treatment.

(c) All dissimilar metal weld joints, such as in austenitic or high nickel to ferritic material or using austenitic or high nickel alloy filler metal to join ferritic materials, which penetrate the vessel wall shall be examined after final postweld heat treatment.

(d) Ultrasonic examination of electrosag welds in ferritic materials shall be performed after a grain refining heat treatment, when performed, or after final postweld heat treatment.

NE-5130 EXAMINATION OF WELD EDGE PREPARATION SURFACES

All full penetration weld edge preparation surfaces for joint Categories A, B, C, D, and similar joints in material 2 in. or more in thickness shall be examined by the magnetic particle or liquid penetrant method. Indications shall be evaluated in accordance with the acceptance standards of (a), (b), and (c) below.

(a) Only indications with major dimensions greater than $\frac{1}{16}$ in. (1.5 mm) shall be considered relevant imperfections.

(b) Laminar-type imperfections are acceptable without repair if they do not exceed 1 in. (25 mm) in length. The extent of all laminar-type imperfections exceeding 1 in. (25 mm) in length shall be determined by ultrasonic examination. Imperfections exceeding 1 in. (25 mm) in length shall be repaired by welding to a depth of $\frac{3}{8}$ in. (10 mm)

or the depth of the imperfection, whichever is less, unless the ultrasonic examination reveals that additional depth of repair is required to meet the ultrasonic examination requirement for the product form.

(c) Indications of nonlaminar imperfections of (1) through (3) below are unacceptable:

(1) any linear indications greater than $\frac{3}{16}$ in. (5 mm) long;

(2) rounded indications with dimensions greater than $\frac{3}{16}$ in. (5 mm);

(3) four or more indications, in a line separated by $\frac{1}{16}$ in. (1.5 mm) or less, edge to edge.

(d) Weld repairs made to weld edge preparations for Category A, B, C, D, or similar type welds shall be examined by the magnetic particle or liquid penetrant method before the surfaces become inaccessible. The examination may be performed before or after postweld heat treatment.

NE-5200 REQUIRED EXAMINATION OF WELDS

NE-5210 CATEGORY A WELDED JOINTS

NE-5211 Butt-Welded Joints

Category A welded joints shall be fully radiographed.

NE-5220 CATEGORY B WELDED JOINTS

NE-5221 Butt Welds

Circumferential welds as defined in NE-3351.2 shall be radiographed. The provision of NE-5280 is applicable.

NE-5222 Socket Welds

Socket welds shall be examined by the magnetic particle or liquid penetrant method.

NE-5230 CATEGORY C WELDED JOINTS

NE-5231 Butt Welds

Category C butt welds shall be radiographed.

NE-5232 Non-Butt-Welded Joints

(a) If other than a butt-welded joint detail is used, it shall be examined by the ultrasonic method, magnetic particle method, or liquid penetrant method.

(b) When a pressure-retaining part is to be welded to a plate thicker than $\frac{1}{2}$ in. (13 mm) to form a corner joint as shown in Figures NE-4243-1 and NE-4243-2, sketches (a), (b), and (c), the plate shall be examined before welding on all cut edges adjacent to the weld, including those for weld joint preparation, by magnetic particle or liquid penetrant examination. After welding, all such edges that remain exposed shall be reexamined. Where the material is nonmagnetic, only the liquid penetrant method shall be used.

NE-5240 CATEGORY D WELDED JOINTS

NE-5241 Butt Welds

Category D butt welds shall be radiographed.

NE-5242 Non-Butt-Welded Joints

If other than a butt-welded joint detail is used, it shall be examined by an ultrasonic method, a magnetic particle method, or a liquid penetrant method. Welds on reinforcing plates attached to the outside of the vessel shall be solution film tested with a pressure of at least 15 psi (100 kPa) under the reinforcing plate.

NE-5244 Weld Buildup Deposits for Openings and Nozzles

When weld buildup deposits are made to a surface as shown in Step 1 of Figure NE-4244(c)-1, the weld buildup deposit, the fusion zone, and the parent metal beneath the weld buildup deposit shall be ultrasonically examined to assure freedom from lack of fusion and laminar defects. Opening structures or nozzles may then be attached by a full penetration weld as shown in Step 2 of Figure NE-4244(c)-1. The full penetration weld shall be examined in accordance with NE-5241.

NE-5260 ATTACHMENTS

NE-5261 Butt-Welded Joints

All butt-welded joints in pressure-retaining parts not included in Categories A, B, C, and D, such as those on doors, opening frames, permanent attachments, and similar construction, shall be radiographed. Butt welds in non-pressure-retaining structural parts attached to pressure-retaining parts shall be fully radiographed for a minimum distance of $16t$, where t is the thickness of the structural part.

NE-5262 Non-Butt-Welded Joints

If other than a butt-welded joint detail is used on pressure-retaining parts, it shall be examined by an ultrasonic method, a magnetic particle method, or a liquid penetrant method, all in accordance with NE-5110. For non-pressure-retaining structural parts attached to pressure-retaining parts in which nonbutt-welds are used, the portion of the attachment within the limit of $16t$ shall be examined in the same manner.

NE-5270 SPECIAL WELDS

Weld metal cladding shall be examined by the liquid penetrant method.

NE-5278 Electroslag Welds

In addition to the requirements for the type of weld being examined, all complete penetration welds made by the electroslag welding process in ferritic materials shall be ultrasonically examined.

NE-5280 SPECIAL EXCEPTIONS FOR RADIOGRAPHY

(a) When the joint detail does not permit radiographic examination to be performed in accordance with this Article, ultrasonic examination plus liquid penetrant or magnetic particle examination of the completed weld may be substituted for the radiographic examination. The absence of suitable radiographic equipment shall not be justification for such a substitution. The substitution of ultrasonic examination can be made, provided the examination is performed using a detailed written procedure that has been proven by actual demonstration to the satisfaction of the Inspector as capable of detecting and locating defects described in this Subsection. The nondestructive examination shall be in accordance with NE-5110 and shall meet the acceptance standards of NE-5300.

(b) As permitted by NE-3352.2(b), surface examination of the root pass and completed weld in accordance with NE-5340 or NE-5350 may be substituted for radiographic examination required in NE-5221 for Category B butt welds in electrical penetration assemblies. In addition, for welds thicker than a nominal $\frac{3}{8}$ in. (10 mm), an intermediate surface examination shall be performed at approximately half the weld thickness to be deposited.

NE-5300 ACCEPTANCE STANDARDS**NE-5320 RADIOGRAPHIC ACCEPTANCE STANDARDS**

Indications shown on the radiographs of welds and characterized as imperfections are unacceptable under the following conditions:

(a) any indication characterized as a crack or zone of incomplete fusion or penetration;

(b) any other elongated indication which has a length greater than

(1) $\frac{1}{4}$ in. (6 mm) for t up to $\frac{3}{4}$ in. (19 mm), inclusive

(2) $\frac{1}{3}t$ for t from $\frac{3}{4}$ in. to $2\frac{1}{4}$ in. (19 mm to 57 mm), inclusive

(3) $\frac{3}{4}$ in. (19 mm) for t over $2\frac{1}{4}$ in. (57 mm)

where t is the thickness of the thinner portion of the weld;

(c) internal root weld conditions are acceptable when the density change or image brightness difference as indicated in the radiograph is not abrupt; elongated indications on the radiograph at either edge of such conditions shall be unacceptable, as provided in (b) above;

(d) any group of aligned indications having an aggregate length greater than t in a length of $12t$ unless the minimum distance between successive indications exceeds $6L$, in which case the aggregate length is unlimited, L being the length of the largest indication;

(e) rounded indications in excess of that shown as acceptable in Section III Appendices, Mandatory Appendix VI.

NE-5330 ULTRASONIC ACCEPTANCE STANDARDS

All imperfections which produce a response greater than 20% of the reference level shall be investigated to the extent that the operator can determine the shape, identity, and location of all such imperfections and evaluate them in terms of the acceptance standards as given in (a) and (b) below.

(a) Imperfections are unacceptable if the indications exceed the reference level amplitude and have lengths exceeding

(1) $\frac{1}{4}$ in. (6 mm) for t up to $\frac{3}{4}$ in. (19 mm), inclusive

(2) $\frac{1}{3}t$ for t from $\frac{3}{4}$ in. to $2\frac{1}{4}$ in. (19 mm to 57 mm), inclusive

(3) $\frac{3}{4}$ in. (19 mm) for t over $2\frac{1}{4}$ in. (57 mm)

where t is the thickness of the weld being examined; if a weld joins two members having different thicknesses at the weld, t is the thinner of these two thicknesses.

(b) Indications characterized as cracks, lack of fusion, or incomplete penetration are unacceptable regardless of length.

NE-5340 MAGNETIC PARTICLE ACCEPTANCE STANDARDS**NE-5341 Evaluation of Indications**

(a) Mechanical discontinuities at the surface are revealed by the retention of the examination medium. All indications are not necessarily defects, however, since certain metallurgical discontinuities and magnetic permeability variations may produce similar indications which are not relevant.

(b) Any indication which is believed to be nonrelevant shall be reexamined by the same or other nondestructive examination methods to verify whether or not actual defects are present. Surface conditioning may precede the reexamination. After an indication has been verified to be nonrelevant, it is not necessary to reinvestigate repetitive nonrelevant indications of the same type. Nonrelevant indications which would mask defects are unacceptable.

(c) Relevant indications are indications which result from imperfections. Linear indications are indications in which the length is more than three times the width. Rounded indications are indications which are circular or elliptical with the length equal to or less than three times the width.

NE-5342 Acceptance Standards

(a) Only imperfections producing indications with major dimensions greater than $\frac{1}{16}$ in. (1.5 mm) are required to be evaluated for acceptance.

(b) Imperfections producing the following indications are unacceptable:

(1) linear indications with dimensions greater than $\frac{1}{16}$ in. (1.5 mm);

(2) rounded indications with dimensions greater than $\frac{3}{16}$ in. (5 mm);

(3) four or more rounded indications in a line separated by $\frac{1}{16}$ in. (1.5 mm) or less edge to edge;

(4) ten or more rounded indications in any 6 in.² (4 000 mm²) of surface with the major dimension of this area not to exceed 6 in. (150 mm) with the area taken in the most unfavorable location relative to the indications being evaluated.

NE-5350 LIQUID PENETRANT ACCEPTANCE STANDARDS**NE-5351 Evaluation of Indications**

(a) Mechanical discontinuities at the surface are revealed by bleeding out of the penetrant; however, localized surface discontinuities such as may occur from machining marks or surface conditions may produce similar indications which are nonrelevant.

(b) Any indication that is believed to be nonrelevant shall be reexamined to verify whether or not actual defects are present. Surface conditioning may precede the reexamination. Nonrelevant indications and broad areas of pigmentation which would mask defects are unacceptable.

(c) Relevant indications are indications which result from imperfections. Linear indications are indications in which the length is more than three times the width. Rounded indications are indications which are circular or elliptical with the length equal to or less than three times the width.

NE-5352 Acceptance Standards

(a) Only imperfections producing indications with major dimensions greater than $\frac{1}{16}$ in. (1.5 mm) are required to be evaluated for acceptance.

(b) Imperfections producing the following indications are unacceptable:

(1) linear indications with dimensions greater than $\frac{1}{16}$ in. (1.5 mm);

(2) rounded indications with dimensions greater than $\frac{3}{16}$ in. (5 mm);

(3) four or more rounded indications in a line separated by $\frac{1}{16}$ in. (1.5 mm) or less edge to edge;

(4) ten or more rounded indications in any 6 in.² (4 000 mm²) of surface with the major dimension of this area not to exceed 6 in. (150 mm) with the area

taken in the most unfavorable location relative to the indications being evaluated.

NE-5500 QUALIFICATIONS AND CERTIFICATION OF NONDESTRUCTIVE EXAMINATION PERSONNEL**NE-5510 GENERAL REQUIREMENTS**

Organizations performing Code required nondestructive examinations shall use personnel competent and knowledgeable to the degree specified by NE-5520. When these services are subcontracted by the Certificate Holder or Quality System Certificate Holder, he shall verify the qualification of personnel to the requirements of NE-5520. All nondestructive examinations required by this Subsection shall be performed by and the results evaluated by qualified nondestructive examination personnel.

NE-5520 PERSONNEL QUALIFICATION, CERTIFICATION, AND VERIFICATION**NE-5521 Qualification Procedure**

(a) Personnel performing nondestructive examinations shall be qualified in accordance with the recommended guidelines of SNT-TC-1A.^{14, 15} The ACCP Level II and III provisions for qualification and certification and the ASNT administered Level II certification provision for qualification and certification of NDE Personnel shall not be used for Section III. The Employer's¹⁶ written practice required by paragraph 5 of SNT-TC-1A shall identify his requirements relative to the recommended guidelines. The recommended guidelines of SNT-TC-1A shall be considered minimum requirements, except as modified in (1) through (5) below.

(1) Qualification of Level III nondestructive examination personnel shall be by examination.

(-a) The basic and method examinations, paragraphs 8.8.1 and 8.8.2 of SNT-TC-1A, may be prepared and administered by the Employer, ASNT, or an outside agency.

(-b) The specific examination, paragraph 8.8.3 of SNT-TC-1A, shall be prepared and administered by the Employer or an outside agency. The Employer or outside agency administering the specific examination shall identify the minimum grade requirement in the written program when the basic and method examinations have been administered by ASNT, which issues grades on a pass/fail basis. In this case, the minimum grade for the specific examination may not be less than 80%.

(2) The written practice identified in paragraph 5 of SNT-TC-1A and the procedures used for examination of personnel shall be referenced in the Employer's Quality Program.

(3) The number of hours of training and experience for nondestructive examination personnel who perform only one operation of a nondestructive examination method that consists of more than one operation, or perform nondestructive examination of limited scope, may be less than that recommended in Table 6.3.1 A of SNT-TC-1A. The training and experience times shall be described in the written practice, and any limitations or restrictions placed on the certification shall be described in the written practice and on the certificate.

The minimum classroom training times for visual examination personnel identified in Table 6.3.1 A of SNT-TC-1A for Level II certification may be reduced from 16 hr to 8 hr.

(4) For the near-vision acuity examination, the Jaeger Number 1 letters shall be used in lieu of the Jaeger Number 2 letters specified in paragraph 8.2.1 of SNT-TC-1A. The use of equivalent type and size letters is permitted.

(5) An NDE Level I individual shall be qualified to properly perform specific setups, specific calibrations, specific NDE, and specific evaluations for acceptance or rejection determinations according to written instructions, and to record results. The NDE Level I individual shall receive the necessary instruction and supervision from a certified NDE Level II or Level III individual. A Level I individual may independently accept the results of nondestructive examinations when the specific acceptance criteria are defined in the written instructions.

(b) For nondestructive examination methods not covered by SNT-TC-1A documents, personnel shall be qualified to comparable levels of competency by subjecting to comparable examinations on the particular method involved.

(c) The emphasis shall be on the individual's ability to perform the nondestructive examination in accordance with the applicable procedure for the intended application.

(d) For nondestructive examination methods that consist of more than one operation or type, it is permissible to use personnel qualified to perform one or more operations. As an example, one person may be used who is qualified to conduct radiographic examination and another may be used who is qualified to interpret and evaluate the radiographic film.

NE-5522 Certification of Personnel

(a) The Employer retains responsibility for the adequacy of the program and is responsible for certification of Levels I, II, and III nondestructive examination personnel.

(b) When ASNT is the outside agency administering the Level III basic and method examinations [NE-5521(a)(1)(-a)], the Employer may use a letter from ASNT as evidence on which to base the certification.

(c) When an outside agency is the examining agent for Level III qualification of the Employer's personnel, the examination results shall be included with the Employer's record.

NE-5523 Verification of Nondestructive Examination Personnel Certification

The Certificate Holder has the responsibility to verify the qualification and certification of nondestructive examination personnel employed by Material Organizations qualified by them in accordance with NCA-3820 and subcontractors who provide nondestructive examination services to them.

NE-5530 RECORDS

Personnel qualification records identified in paragraph 9.4 of SNT-TC-1A shall be retained by the Employer.

NE-5700 EXAMINATION REQUIREMENTS FOR EXPANSION JOINTS

NE-5710 BELLOWS EXPANSION JOINTS

The examinations stipulated in (a) through (f) below are required to verify the integrity of bellows expansion joints for installation in nuclear containment systems.

(a) The formed bellows shall be determined by visual examination to be free of defects, such as notches, crevices, material buildup or upsetting, and weld spatter which may serve as points of local stress concentration. Suspect surface areas shall be further examined by liquid penetrant examination in accordance with NE-5110.

(b) The longitudinal welds in the bellows shall be examined by the liquid penetrant method in accordance with NE-5111. When the individual ply thickness exceeds $\frac{1}{8}$ in. (3 mm), the weld shall also be radiographed in accordance with NE-5111. These examinations may be performed either before or after the bellows is formed.

(c) The circumferential attachment weld between the bellows and weld ends or flanges shall be liquid penetrant examined in accordance with NE-5110 when the total bellows thickness is $\frac{1}{4}$ in. (6 mm) or less. When the total thickness exceeds this limit, the weld shall be radiographed in accordance with NE-5110 except where radiography is not meaningful, i.e., when the weld thickness constitutes less than 20% of the total thickness being radiographed, liquid penetrant examination may be substituted.

(d) In the case of liquid penetrant examination of bellows weld joints, imperfections producing the following indications are unacceptable:

- (1) cracks or linear indications;
- (2) four or more rounded indications in a line separated by $\frac{1}{16}$ in. (1.5 mm) or less edge to edge;
- (3) five or more randomly distributed rounded indications in a weld length of 6 in. (150 mm);

(4) any rounded indication exceeding the lesser of one-half the bellows thickness or $\frac{1}{16}$ in. (1.5 mm) in diameter.

(e) The examination of all other welds in the expansion joint shall comply with [Article NE-5000](#).

(f) The variation of the cylindrical end thickness of the formed bellows from the nominal or specified thickness shall not exceed the values given in Section II, Part A, SA-480/SA-480M, Table 2. Thinning of the bellows material during forming shall be considered in the design and selection of material thickness but need not be limited to values specified in Section II, Part A, SA-480/SA-480M, Table 2.

ARTICLE NE-6000

TESTING

NE-6100 GENERAL REQUIREMENTS

NE-6110 PRESSURE TESTING OF VESSELS AND APPURTENANCES

(21) NE-6111 Scope of Pressure Testing

All pressure-retaining vessels and appurtenances (hereafter reference is to vessels only) shall be pressure tested. Bolts, studs, nuts, washers, nonwelded access opening covers, and gaskets are exempted from the pressure test.

NE-6112 Pneumatic Testing

A pneumatic test in accordance with [NE-6300](#) may be substituted for the hydrostatic test when permitted by [NE-6112.1\(a\)](#).

NE-6112.1 Pneumatic Test Limitations.

(a) A pneumatic test may be used in lieu of a hydrostatic test only when any of the following conditions exists:

(1) when the vessels are so designed or supported that they cannot be safely filled with liquid;¹⁷

(2) when the vessels, which are not readily dried, are to be used in services where traces of the testing medium cannot be tolerated.

(b) A pneumatic test at a pressure not to exceed 10% of the test pressure may be applied prior to either a hydrostatic or a pneumatic test as a means of locating leaks.

NE-6112.2 Precautions to Be Employed in Pneumatic Testing. Compressed gaseous fluid is hazardous when used as a testing medium. It is therefore recommended that special precautions for protection of personnel be taken when a gaseous fluid under pressure is used as a test medium.

NE-6113 Witnessing of Pressure Tests

Pressure testing required by this Article shall be performed in the presence of the Inspector.

NE-6120 PREPARATION FOR TESTING

NE-6121 Exposure of Joints

All joints, including welded joints, shall be left uninsulated and exposed for examination during the test, except as permitted in [NE-6225](#).

NE-6122 Addition of Temporary Supports

Vessels designed to contain vapor or gas may be provided with additional temporary supports, if necessary, to support the weight of the test liquid.

NE-6123 Restraint or Isolation of Expansion Joints

Expansion joints shall be provided with temporary restraints, if required, for the additional pressure load under test.

NE-6124 Isolation of Equipment Not Subjected to Pressure Test

Equipment that is not to be subjected to the pressure test shall be either disconnected from the vessel or isolated during the test by a blind flange or similar means. Valves may be used if the valves with their closures are suitable for the proposed test pressure.

NE-6125 Treatment of Flanged Joints Containing Blanks

Flanged joints at which blanks are inserted to isolate other equipment during the test need not be retested.

NE-6126 Precautions Against Test Medium Expansion

If a pressure test is to be maintained for a period of time and the test medium in the system is subject to thermal expansion, precautions shall be taken to avoid excessive pressure.

NE-6127 Check of Test Equipment Before Applying Pressure

The test equipment shall be examined before pressure is applied to ensure that it is tight and that all low pressure filling lines and other items that should not be subjected to the test have been disconnected or isolated.

NE-6200 HYDROSTATIC TESTS

NE-6210 HYDROSTATIC TEST PROCEDURE

NE-6211 Venting During Fill Operation

The vessel in which the test is to be conducted shall be vented during the filling operation to minimize air pocketing.

NE-6212 Test Medium and Test Temperature

(a) Water or an alternative liquid, as permitted by the Design Specification, shall be used for the hydrostatic test.

(b) It is recommended that the test be made at a temperature that will minimize the possibility of brittle fracture. The test pressure shall not be applied until the vessel and the pressurizing fluid are at approximately the same temperature.

NE-6220 HYDROSTATIC TEST PRESSURE REQUIREMENTS

NE-6221 Minimum Hydrostatic Test Pressure

The vessel shall be hydrostatically tested at not less than 1.2 times the Design Pressure.

NE-6222 Maximum Permissible Test Pressure

The stress limits specified in [NE-3226](#) shall be used in determining the maximum permissible test pressure. In multichamber components, pressure may be simultaneously applied to the appropriate adjacent chamber to satisfy these stress limits.

NE-6223 Hydrostatic Test Pressure Holding Time

The hydrostatic test pressure shall be maintained a minimum of 10 min prior to initiation of the examination for leakage required by [NE-6224](#).

NE-6224 Examination for Leakage After Application of Pressure

Following the application of the hydrostatic test pressure for the required time ([NE-6223](#)), all joints, connections, and regions of high stress, such as regions around openings and thickness transition sections, shall be examined for leakage, except as provided in [NE-6225](#). This examination shall be made at a pressure equal to the greater of the Design Pressure or three-fourths of the test pressure, and it shall be witnessed by the Inspector. Leakage of temporary gaskets and seals, installed for the purpose of conducting the hydrostatic test and which will be replaced later, may be permitted unless the leakage exceeds the capacity to maintain system test pressure for the required amount of time. Other leaks, such as those from permanent seals, seats, and gasketed joints in components, may be permitted when specifically allowed by the Design Spec-

ification. Leakage from temporary seals or leakage permitted by the Design Specification shall be directed away from the surface of the component to avoid masking leaks from other joints.

NE-6225 Examination of Inaccessible Welds

Examination of inaccessible pressure-retaining welds of containment vessels during the pressure test is waived where such joints are covered by concrete or otherwise made inaccessible during construction of the vessel, provided that:

(a) no openings or penetrations are embedded in the concrete;

(b) the nozzle is integrally reinforced and is attached to the shell by a full penetration weld;

(c) prior to being covered or made inaccessible, the welds are examined by the radiographic or ultrasonic method;

(d) prior to being covered or made inaccessible, the welded joint is tested for leak tightness using a gas medium test such as the Halide Leak Detection Test or Vacuum Box Test.

NE-6230 BELLOWS EXPANSION JOINTS

The hydrostatic test requirements for bellows expansion joints shall be as required in (a) through (c) below.

(a) The completed expansion joint shall be subjected to a hydrostatic test in accordance with the applicable provisions of this Article as supplemented by the Design Specification.

(b) This test may be performed with the bellows fixed in the straight position, at its neutral length, when the design has been shown to comply with [NE-3366.2\(e\)\(1\)](#) or [NE-3366.2\(e\)\(2\)](#). If the design is to comply with [NE-3366.2\(e\)\(3\)](#), this test shall be performed with the bellows fixed at the maximum design rotation angle or offset movement.

(c) In addition to inspecting the expansion joint for leaks and general structural integrity during the test, the Inspector shall also visually inspect the bellows for evidence of meridional yielding as defined in [NE-3366.2\(b\)](#), and for evidence of squirm as defined in [NE-3366.2\(c\)](#). If the design is to comply with [NE-3366.2\(e\)\(3\)](#), actual measurements shall be made before, during, and after the pressure test in accordance with [NE-3366.2\(b\)](#) and [NE-3366.2\(c\)](#).

NE-6300 PNEUMATIC TESTS

NE-6310 PNEUMATIC TESTING PROCEDURES

NE-6311 General Requirements

When a pneumatic test is performed, it shall be conducted in accordance with the requirements of this subarticle and [NE-6100](#). In some cases it is desirable

to test vessels when partly filled with liquids. For such vessels, a combined hydrostatic and pneumatic test may be used as an alternative to the pneumatic test of this paragraph provided the liquid level is set so that the stress intensities of [NE-3226](#) are not exceeded. After setting the liquid level to meet this condition, the test shall be conducted as prescribed in this subarticle.

NE-6312 Test Medium and Test Temperature

(a) The gas used as the test medium shall be nonflammable.

(b) Testing temperature shall be in accordance with [NE-6212\(b\)](#).

NE-6313 Procedure for Applying Pressure

The pressure in the system shall be gradually increased to not more than one-half of the test pressure, after which the pressure shall be increased in steps of approximately one-tenth of the test pressure until the required test pressure has been reached.

NE-6320 PNEUMATIC TEST PRESSURE REQUIREMENTS

NE-6321 Minimum Required Pneumatic Test Pressure

The pneumatic test pressure for vessels shall not be less than 1.1 times the Design Pressure of the vessel.

NE-6322 Maximum Permissible Test Pressure

The maximum test pressure shall be limited as defined in [NE-6222](#).

NE-6323 Test Pressure Holding Time

The test pressure of [NE-6321](#) shall be maintained for a minimum total time of 10 min.

NE-6324 Examination for Leakage After Application of Pressure

Following the application of pressure for the time specified in [NE-6323](#), the test pressure shall be reduced to a value equal to the greater of the Design Pressure or three-fourths of the test pressure and held for a sufficient time to permit examination as defined in [NE-6224](#).

NE-6400 PRESSURE TEST GAGES

NE-6410 REQUIREMENTS FOR PRESSURE TEST GAGES

NE-6411 Types of Gages to Be Used and Their Location

Pressure test gages used in pressure testing shall be indicating pressure gages and shall be connected directly to the vessel. If the indicating gage is not readily visible to the operator controlling the pressure applied, an additional indicating gage shall be provided where it will be visible to the operator for the duration of the test. For vessels with a large volumetric content, it is recommended that a recording gage be used in addition to the indicating gages.

NE-6412 Range of Indicating Pressure Gages

(a) Analog-type indicating pressure gages used in testing shall be graduated over a range not less than $1\frac{1}{2}$ times nor more than 4 times the test pressure.

(b) Digital-type pressure gages may be used without range restriction provided the combined error due to calibration and readability does not exceed 1% of the test pressure.

NE-6413 Calibration of Pressure Test Gages

All test gages shall be calibrated against a standard dead weight tester or a calibrated master gage. The test gages shall be calibrated before each test or series of tests. A series of tests is that group of tests using the same pressure test gage or gages which is conducted within a period not exceeding 2 weeks.

NE-6700 CONTAINMENT PENETRATION

NE-6710 PRESSURE TESTS

NE-6711 Electrical and Mechanical Penetration Assemblies

Electrical and mechanical penetration assemblies shall be tested in accordance with the requirements of this Article, except that when electrical and mechanical penetrations are made following the containment vessel pressure test, the test pressure of the welds connecting the electrical or mechanical penetration to the containment vessel may be less than the required containment test pressure but shall be not less than the design pressure of the containment vessel.

NE-6712 Piping Penetrations

Piping penetration assemblies shall be tested in accordance with the requirements of this Article, except that when piping penetrations are made following the

containment vessel pressure test, the test pressure of the welds connecting the piping to the containment vessel may be less than the required containment test pressure but shall be not less than the design pressure of the containment vessel. The provisions of NB-6111 or

NC-6111, as appropriate, apply to the process piping portion of the penetration assembly. The N-5 Data Report Form shall identify the test pressure used for each of the above pipe penetration weld connections.

ARTICLE NE-7000

OVERPRESSURE PROTECTION

NE-7100 GENERAL REQUIREMENTS

NE-7110 SCOPE

(a) A containment vessel shall be protected from the consequence arising from the application of conditions of pressure and coincident temperature that would cause the Service or Test Limits specified in the Design Specification to be exceeded. Pressure relief or vacuum relief devices are not required where the Service or Test Limits specified in the Design Specification are not exceeded.

(b) Pressure relief devices not permanently installed in accordance with NE-7141 shall be removed from the containment vessel before placing the vessel in service.

(c) It is recognized that the fundamental purpose of a containment vessel may be nullified by the incorporation of pressure relief valves discharging directly into the environment. Vacuum relief devices or systems, including venting with controlled discharge or condensation systems, may be essential to protect against differential pressures in excess of design external pressures.

NE-7111 General Definitions

(a) *Overpressure*, as used in this Article, refers to changes in differential pressure resulting from thermal imbalances and similar phenomena capable of causing a differential pressure change of sufficient duration to be compatible with the dynamic response characteristics of the pressure relief devices listed in this Article.

(b) The basic definitions of pressure relief devices as specified in this Article are given in ASME PTC 25.

(c) *Primary Pressure* is the pressure of the fluid at the inlet of the pressure relief device.

(d) *Secondary Pressure* is that value of pressure existing in the passage between the actual discharge area and the outlet for which the discharge system of the pressure relief devices shall be designed.

NE-7120 INTEGRATED OVERPRESSURE PROTECTION

Overpressure protection of the components shall be provided by one of the following methods as an integrated overpressure protection:

(a) the use of vacuum relief or pressure relief devices, or both, and their associated pressure-sensing elements; or

(b) a component designed not to exceed Service Limits specified in the Design Specification (pressure relief devices are not required on containment vessels designed and built to safely contain all radioactive substances that may be released into the containment atmosphere).

NE-7130 PROVISIONS FOR CHECKING OPERATION OF PRESSURE RELIEF DEVICES

NE-7131 Design Provisions

Relief devices shall be designed so that potential impairment of the overpressure protection function from service exposure to fluids can be determined by test or examination.

NE-7132 Construction Provisions

Relief devices shall be constructed and installed so that their correct operation and the reliability of their associated pressure-sensing elements under service or test conditions can be demonstrated, as may be required by regulatory and enforcement authorities having jurisdiction at the nuclear power plant site.

NE-7140 INSTALLATION PROVISIONS

NE-7141 Installation of Relief Devices

(a) The connection between a component and its pressure relief valve shall have a minimum inside diameter equal to or greater than the nominal size of the pressure relief valve inlet. The opening in the connection shall be designed to provide direct and unobstructed flow between the component and its pressure relief valve. Pressure drop resulting from the accumulated line losses between the protected component and the relief valve shall be compatible with the valve performance characteristic.

(b) Spring-loaded pressure relief valves should normally be installed in the upright position with the spindle vertical. Where space or piping configuration precludes such an installation, the valve may be installed in other than the vertical position, provided the following conditions are met:

(1) the valve design is confirmed by the NV Certificate Holder with documentation as being satisfactory for such position; and

(2) the valve has been pressure tested in the same position as the installation.

(c) The area of the discharge piping from a pressure relief device shall not be less than the area of the discharge connection. The size and length of the discharge piping shall be such that any back pressure that may exist or develop will not reduce the relieving capacity below that required to protect the components.

NE-7142 Provisions When Stop Valves Are Used

No stop valves or other devices shall be placed in the inlet or discharge lines of a relief device so that they could reduce the protection below that required by the rules of this Article, unless such stop valves are constructed and installed with controls and interlocks so that the relieving capacity requirements are met under all conditions of operation. Means shall be provided to verify that the operation of controls and interlocks can be verified.

NE-7150 ACCEPTABLE PRESSURE RELIEF DEVICES

NE-7151 Pressure Relief Valves

Pressure relief valves shall meet the Construction requirements applicable to Class 2 valves.

NE-7152 Vacuum Relief Devices

(a) Vacuum relief devices shall meet the construction requirements applicable to Class 2 valves and the additional requirements of this Article.

(b) Balanced self-actuating, horizontally installed, swinging disk valves, or vertically installed, vacuum disk or pallet-type valves, with provisions for adjustment of the differential pressure under which the valves operate, are acceptable types.

(c) Valve devices intended to provide vacuum relief, and which are operated by indirect means depending upon an external energy source, such as electrical, pneumatic, or hydraulic systems, are not acceptable unless the conditions given in (1) and (2) below are met:

(1) at least two independent external power-operated valve and control systems are employed so that the required relieving capacity is obtained if any one of the valve systems should fail to operate when called upon to do so; and

(2) at least one self-actuating vacuum relief device, of a type specified in (b) above, of equivalent relieving capacity is provided in series with each of the external power-operated valves.

NE-7160 UNACCEPTABLE RELIEF DEVICES

NE-7161 Nonreclosing Pressure Relief Devices

Nonreclosing pressure relief devices are unacceptable.

NE-7200 OVERPRESSURE PROTECTION REPORT

NE-7210 RESPONSIBILITY FOR REPORT

The provisions intended to meet the requirements of this Article shall be the subject of an Overpressure Protection Report prepared by the Owner or his designee.

NE-7220 CONTENT OF REPORT

The Overpressure Protection Report shall define the protected vessel and the integrated overpressure protection provided. As a minimum, the report shall include (a) through (k) below:

(a) identification of specific ASME Section III, Article NE-7000 Edition and Addenda and applicable Code Cases used in the design of the overpressure protection system;

(b) drawings showing the arrangement of the protected vessel, including the pressure and/or vacuum relief devices employed;

(c) the range of operating conditions, including the effect of discharge piping back pressure under which the pressure relief devices are required to function;

(d) an analysis of the conditions that give rise to the maximum pressure and/or vacuum relieving requirements;

(e) the relief capacity required to prevent a differential pressure in the vessel in accordance with the requirements in NE-7300;

(f) the operating controls or safety controls of the protected vessel upon which the anticipated required relief capacity of (d) above, and the maximum pressure and temperature of (c) above are predicted;

(g) the redundancy and independence of the pressure and/or vacuum relief devices, and their associated pressure sensors and controls employed to preclude a loss of overpressure protection in the event of a failure of any pressure or vacuum relief device, sensing element, associated control, or external power source;

(h) the design secondary pressure, including a justification of the value identified in the Design Specification for pressure relief devices;

(i) the analysis of pressure transient conditions, including those associated with the response time of pressure and/or vacuum relief devices;

(j) consideration of set pressure and blowdown limitations in accordance with NE-7500, taking into account opening pressure tolerances and overpressure of the pressure relief device;

(k) when pressure relief devices are not required, verification is to include reference to the applicable requirement in Article NE-3000 that demonstrates that the Service Limits for the vessel do not exceed the Service Limits specified in the Design Specification for all service loadings.

NE-7230 CERTIFICATION OF REPORT

The report, after it has been reconciled with the requirements of this Article, shall be certified by one or more Certifying Engineers competent in the applicable field of design and qualified in accordance with the requirements of Section III Appendices, Mandatory Appendix XXIII.

NE-7240 REVIEW OF REPORT AFTER INSTALLATION

(a) After completion of the installation of the protected vessel an as-built drawing shall be prepared. The Owner or his designee shall review the Overpressure Protection Report against the as-built vessel.

(b) The results of this review shall be documented in an addendum to the Overpressure Protection Report. The addendum shall contain a copy of the as-built drawing and shall include either:

(1) a statement that the as-built vessel meets the requirements of the Overpressure Protection Report; or

(2) a revision to the Overpressure Protection Report to make it agree with the as-built vessel; or

(3) a description of the changes made to the as-built vessel to make it comply with the Overpressure Protection Report.

(c) The addendum shall be certified by one or more Certifying Engineers competent in the applicable field of design and qualified in accordance with the requirements of Section III Appendices, Mandatory Appendix XXIII.

NE-7250 FILING OF REPORT

A copy of the Overpressure Protection Report shall be filed at the nuclear power plant site prior to the Inspector or Authorized Nuclear Inspector signing the Owner's Data Report. The report shall be made available to the Authorized Nuclear Inspector and the enforcement authorities having jurisdiction at the plant site.

NE-7300 RELIEVING CAPACITY REQUIREMENTS**NE-7310 RELIEVING CAPACITY OF PRESSURE RELIEF DEVICES**

The total rated relieving capacity of the pressure relief devices shall take into account any limitations due to fluid flow-through piping and other components.

NE-7311 Relieving Capacity of Vacuum Relief Devices

(a) The total rated relieving capacity of the vacuum relief devices shall take into account any limitations due to fluid flow-through piping and other components.

(b) The rated capacity of each vacuum relief device shall not be less than that required to prevent a differential pressure in excess of the value specified in the Design Specification.

(c) At least two independent vacuum relief devices shall be provided on each containment vessel, except on vessels designed to withstand the maximum expected differential pressure. The capacity of each vacuum relief device shall not be less than that required to protect the component.

NE-7400 SET PRESSURES OF PRESSURE RELIEF DEVICES**NE-7410 SET PRESSURE LIMITATIONS FOR TESTING CONDITIONS**

The set pressure of the pressure relief devices connected to the vessel shall meet the requirements of [Article NE-6000](#) and [NE-7110](#).

NE-7500 OPERATING DESIGN REQUIREMENTS FOR PRESSURE RELIEF VALVES**NE-7510 PRESSURE RELIEF VALVES****NE-7511 General Requirements**

NE-7511.1 Spring-Loaded Valves. Valves shall open automatically by direct action of the fluid pressure as a result of forces acting against a spring.

NE-7512 Pressure Relief Valve Operating Requirements

Pressure relief valves shall be constructed to attain rated lift at a pressure which does not exceed the set pressure by more than 10% or 3 psi (20 kPa), whichever is greater.

NE-7512.1 Opening Pressure Tolerance.

(a) The opening pressure tolerance plus or minus from the set pressure of pressure relief valves shall not exceed 2 psi (15 kPa) for pressure up to and including 70 psi (485 kPa) and 3% for pressure above 70 psi (485 kPa).

(b) Conformance with the requirements of (a) above shall be established for each production valve by test. Valves shall be tested with air or gas.

NE-7512.2 Blowdown Requirements. Pressure relief (21) valves shall be constructed to close after blowing down to a pressure not lower than that specified in the valve Design Specification (NCA-3211.19). The blowdown shall be determined by test or by proration from the Certificate Holder's blowdown test data.

(21) NE-7513 Relieving Capacity

The relieving capacity of pressure relief valves of the types permitted in this subarticle shall be based on the stamped relieving capacity and proration of capacity as determined by Section XIII, 9.9(d).

NE-7514 Sealing Requirements

Means shall be provided in the construction of all pressure relief valves for sealing all external adjustments. Seals shall be installed by the Certificate Holder at the time of setting. Seals shall be installed in such a manner as to prevent changing the adjustment without breaking the seal and shall serve as a means of identifying the Certificate Holder.

NE-7520 POWER-ACTUATED PRESSURE RELIEF VALVES

Power-actuated pressure relief valves, which depend upon an external energy source such as electrical, pneumatic, or hydraulic systems, and which respond to signals from pressure or temperature sensing devices may be used, provided the requirements of [NE-7521](#) and [NE-7522](#) are met.

(21) NE-7521 Sensors and Controls

The relief valve and its auxiliary devices treated as a combination shall comply with the following requirements:

(a) The valve opening pressure shall be controlled within a tolerance of $\pm 1\%$ of the set pressure when the automatic control is in use.

(b) The valve blowdown shall be controlled to a pressure not lower than that specified in the valve Design Specification (NCA-3211.19).

NE-7522 Relieving Capacity

The total stamped relieving capacity of the valve or valves shall be equivalent to or greater than the required relieving capacity.

(21) NE-7700 CERTIFICATION REQUIREMENTS**NE-7710 RESPONSIBILITY FOR CERTIFICATION OF PRESSURE RELIEF VALVES**

(a) The Certificate Holder shall be responsible for having the relieving capacity of valves certified as prescribed in Section XIII, Part 9.

(b) Capacity certification obtained in compliance with other Sections and which complies with this Section is qualified for capacity certification under these rules, and the valve may be stamped with the appropriate Certification Mark of this Section.

NE-7800 MARKING, STAMPING WITH CERTIFICATION MARK, AND DATA REPORTS**NE-7810 PRESSURE AND VACUUM RELIEF VALVES****NE-7811 Marking and Stamping With Certification Mark**

Each pressure relief valve shall be plainly marked by the Certificate Holder with the required data below in such a way that the marking will not be obliterated in service. The data shall be in characters not less than $\frac{3}{32}$ in. (2.5 mm) high. The marking shall be placed on the valve or on a nameplate securely fastened to the valve. The Certification Mark with NV Designator shall be stamped on the valve or nameplate, but the other required data may be stamped, etched, impressed, or cast. The marking shall include the following:

(a) name, or an acceptable abbreviation, of the Certificate Holder

(b) Certificate Holder's design or type number

(c) size ____ {[NPS (DN)], the nominal pipe size} of the valve inlet

(d) set pressure ____ psi (kPa)

(e) certified capacity and overpressure in percent or psi in accordance with [NE-7700](#)

(1) *Pressure Relief Valves*

____ lb/hr (kg/hr) of saturated steam for valves certified on steam, or

____ scfm (standard cubic feet per minute) at 60°F (20°C) and 14.7 psia (101 kPa) of air for valves certified on air or gas, or

____ gal/min (L/min) of water at 70°F (20°C) for valves certified on water

(2) *Vacuum Relief Valves*

____ scfh (standard cubic feet per hour) at 60°F (20°C) and 14.7 psi (101 kPa)

(f) applicable official Certification Mark, as shown in Table NCA-8100-1

In addition to the above, each pressure relief valve shall have a separate nameplate attached to the component that includes the marking requirements of NCA-8220.

ARTICLE NE-8000 NAMEPLATES, STAMPING WITH CERTIFICATION MARK, AND REPORTS

NE-8100 REQUIREMENTS

Containment vessels shall be stamped with the Certification Mark with N Designator. Parts and appurtenances, which are part of the containment vessel, shall be stamped with the Certification Mark with NPT Designator. The ap-

plicable requirements given in Article NCA-8000 shall apply to metal containment vessels. In addition to the information required by NCA-8220, both the vessel nameplate and the Certificate Holder's Data Report shall include the lowest service metal temperature.⁴

ENDNOTES

- 1 Because of the different thermal coefficients of expansion of dissimilar materials, caution should be exercised in design and construction under the provisions of [NE-2125](#) in order to avoid difficulties in service under extreme temperature conditions, or with unusual restraint of parts such as may occur at points of stress concentration and also because of metallurgical changes occurring at elevated temperatures.
- 2 Any postweld heat treatment time that is anticipated to be applied to the material or item after it is completed shall be specified in the Design Specification. The Certificate Holder shall include this time in the total time at temperature specified to be applied to the test specimens.
- 3 T — temperature at or above the nil-ductility transition temperature NDT (ASTM E208); T is 10°F (5.6°C) below the temperature at which at least two specimens show no-break performance.
- 4 The *Lowest Service Metal Temperature* shall be the lowest temperature that the metal may experience in service while the plant is in operation and shall be established by appropriate calculations based on atmospheric ambient conditions, the insulation or enclosure provided, and the minimum temperature that will be maintained inside the vessel during the plant operation.
- 5 The requirements for impact testing of the heat-affected zone ([NE-4335.2](#)) may result in reduced test temperatures or increased toughness requirements for the base material.
- 6 The *Lowest Overpressure Test Metal Temperature* shall be the lowest temperature that the metal may experience during the overpressure test. It shall be established by appropriate calculations based on atmospheric conditions, the insulation or enclosure provided, and the temperature that will be maintained inside the vessel during the test.
- 7 The methods given in the Appendix of SFA 5.9, Specification for Corrosion-Resisting Chromium and Chromium-Nickel Steel Welding Rods and Bare Electrodes, shall be used to establish a welding and sampling method for the pad, groove, or other test weld to ensure that the weld deposit being sampled will be substantially free of base metal dilution.
- 8 The volumetric examinations required by [NE-2552](#) need only be conducted from one surface.
- 9 *Communicating chambers* are defined as appurtenances to the vessel that intersect the shell or heads of a vessel and form an integral part of the pressure-retaining closure.
- 10 *Side plates of a flat-sided vessel* are defined as any of the flat plates forming an integral part of the pressure-retaining enclosure.
- 11 For general information, see standards of the Expansion Joint Manufacturers Association, Inc., 25 N. Broadway, Tarrytown, NY 10591.
- 12 One test specimen may represent a group of forgings, provided they are of the same nominal dimensions, from the same heat of material, the same heat treatment lot, and forged in the same manner.
- 13 Welds that are exposed to corrosive action should have a resistance to corrosion that is not substantially less than that of the cladding. The use of filler metal that will deposit weld metal, which is similar to the composition of the cladding material, is recommended. If weld metal of different composition is used, it should have properties compatible with the application.
- 14 SNT-TC-1A is a Recommended Practice for Nondestructive Testing Personnel Qualification and Certification published by the American Society for Nondestructive Testing, 1711 Arlingate Lane, P.O. Box 28518, Columbus, Ohio 43228-0518.
- 15 Personnel qualified by examination and certified to previous editions of SNT-TC-1A are considered to be qualified to the editions referenced in Table NCA-7100-2 when the recertification is based on continuing satisfactory performance. All reexaminations and new examinations shall be in accordance with the applicable edition referenced in Table NCA-7100-2.
- 16 Employer as used in [Article NE-5000](#) shall include: N Certificate Holders; Quality System Certificate Holders; Material Organizations who are qualified in accordance with NCA-3842; and organizations who provide subcontracted nondestructive examination services to organizations described above.
- 17 These tests may be made with the item being tested partially filled with liquid, if desired.
- 18 Valve capacities published in "Pressure Relief Device Certifications." This publication may be obtained from the National Board of Boiler and Pressure Vessel Inspectors, 1055 Crupper Avenue, Columbus, OH 43229.

2021 ASME Boiler and Pressure Vessel Code

AN INTERNATIONAL CODE

The ASME Boiler and Pressure Vessel Code (BPVC) is a globally recognized and trusted source of technical requirements and guidance for the design and construction of boilers, pressure vessels, and nuclear components. With each new edition, the Code continues to evolve, introducing new technologies and processes to promote safety across pressure equipment applications and disciplines. Developed through a rigorous consensus process and fueled by the foresight of leading industry experts from around the world, the ASME BPVC is an ever-evolving set of standards that meets the needs of a changing world.

ASME provides BPVC users with an integrated suite of related offerings, which includes

- referenced standards
- related standards and guidelines
- conformity assessment programs
- learning and development solutions
- ASME Press books and journals



For additional information and to order:

Phone: 1.800.THE.ASME

(1.800.843.2763)

Email: customercare@asme.org

Website: go.asme.org/bpvc

ISBN 978-0-7918-7413-4



9 780791 874134



3 0 0 0 3 E